

SMT Fully Automatic Stencil Printer



I.C.T-4034	I.C.T-5134	I.C.T- 5151	I.C.T-6534	I.C.T-6561	I.C.T-9060



“Industry 4.0”: is the current trend of automation and data exchange in manufacturing technologies. It includes cyber-physical systems, the Internet of things and cloud computing. “Smart Factory”: Within the modular structured smart factories, cyber-physical systems monitor physical processes, create a virtual copy of the physical world and make decentralized decisions. “Information Sharing”: Over the Internet of Things, cyber-physical systems communicate and cooperate with each other and with humans in real time, and via the Internet of Services, both internal and cross-organizational services are offered and used by participants of the value chain.



A Manufacturing Execution System (MES) is a control system for managing and monitoring work-in-process on a factory floor. An MES keeps track of all manufacturing information in real time, receiving up-to-the-minute data from robots, machines and employees. The goal of MES is to improve productivity and reduce cycle-time, total time to produce an order.

Automation is especially attractive in processes where manual interaction can result in quality or safety issues. I.C.T is trying to integrate the industrial 4.0 and MES system, And achieve maximum automation level.

This is the process with SMT printers need to be AUTOMATED

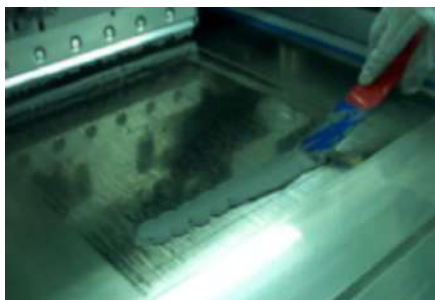

Still relying by hand to supply solder paste?



Continue to waste solder paste? How to ensure quality?



Solder paste is always on both sides, can not clean up?

I.C.T Printer:



Arc cleaning system patent



Cleaning paper consumption check system patent



Cleaning spray system patent



Collision avoidance patent



Dispensing system patent



Fault analysis system patent



Printing accuracy control system patent



Printing process control system patent



Printing quality inspection system patent



Stencil cleaning system patent



Stencil separation speed control system patent



transport patent

Introduce:

I.C.T Automatic Stencil Printer machines are the new benchmark for simple and efficient SMT printing. Its 7-second printing cycle, fast line change settings and high repeatability bring the best results in all directions. Different applications are matched to meet various needs. It is widely used in consumer electronics, automotive electronics, LED and other industries.

Features:

1. High positional accuracy, repeated positioning accuracy $\pm 0.01\text{mm}$; printing accuracy 0.025mm ;
2. Support glue printing, automatic control improves production efficiency, quality control and saves production cost;
3. Automatic PCB calibration, Squeegee pressure adjustable, Automatic printing, Automatic stencil cleaning;
4. Programmable motor controls separation speed and distance among squeegee, stencil and substrate, to realize multi-method separation;
5. Multi-functional PCB positioning system for convenient and accurate PCB positioning;
6. Programmable PCB lifting platform ensure the PCB to lift to a proper height;
7. Adopt company independently developed suspended print head with automatic pressure adjustment system. Support on-line real time pressure feedback and automatic squeegee pressure balancing. Accurate pressure control ensures perfect paste forming effect;
8. Applicable PCB types: LCD TV, STB, LED, family cinema, vehicle electronics, besides general electronics products;
9. SMEMA standard.

TOP Advantage:

1. Simple: Combined with advanced international concepts, based on the Oriental-designed operating system, easy to learn;
2. Expertise: Learn imported printer advanced design concepts, and the machine core components are using imported top brands;
3. Hedging: Import hardware configuration, low failure rate in production, more than a decade service life;
4. Safety: Based on the general rules of international design, close to imported printer rating, the highest security level;
5. Stable: Mature software, hardware and top production processes ensures stability of each equipment.



Print system

Arch bridge suspension type direct connection squeegee structure. The squeegee is independently controlled by two high-precision stepping motors to ensure accurate and stable pressure. The double side slide positioning rails ensure the accuracy and stability of the squeegee before and after operation.



Transport system

The unique belt conveyor system can effectively prevent stuck PCB. The motor controls the speed and the stop position is precise. PCB entry and exit directions are freely available. The side clamps and vacuum are used to effectively clamp the PCB to ensure the smooth contact between PCB and stencil.



Vision system

Uniform ring and high brightness coaxial light source. Advanced up and down matching system. Full range light source adjust can identify various types of Mark. Suitable for tin plating, copper plating, tin spraying, FPC and other PCB to ensure high accuracy and high-quality printing.



Cleaning system

Dry, wet and vacuum cleaning, can also be manual cleaning. CCD and cleaning part are designed separately. Unique spray cleaning system, from top to bottom, spray evenly. Software control alcohol and paper consumption, save materials. Special exhaust motor, vacuum strong and effective.



Platform system

The three axis linkage adjustment system has superb dynamic characteristics and quickly realizes the adjustment of PCB. Drive by direct connection motor, fast and ensure high precision.



Operator system

Windows 10, Friendly MMI interface, teaching and navigation function. Operation log, fault record analysis and other diagnostic functions. New program is controlled within 5-10 minutes.

Option function:

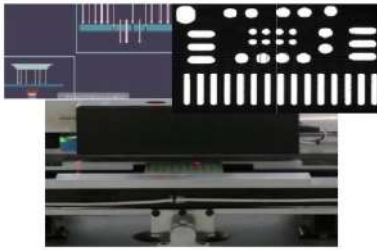

Stencil Inspection System

Through light source compensation using CCD to inspect stencil hole, can quickly detect and judge whether the stencil is clean or not, and automatically clean to ensure that the printing is more perfect.



Auto Supply and Inspect Solder Paste

Software setup time automatically added to ensure the amount of solder paste. Detection of solder paste by sensors can ensure continuous printing for a long time, ensure quality and improve efficiency.

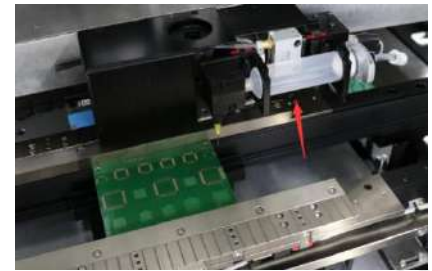

Auto Dispensing System

According to different process requirements, dispensing glue, paste flux, solder paste, dispensing line and other functions. dispensing head has automatic heating function to improve glue flow.



OPC Squeegee

Adjust the print area according to the PCB size, no stagnant solder paste, reduce the amount of solder paste on the stencil, and always maintain the best print quality.



SPI On Line

Connect with SPI to form a closed loop system. When bad information feedback, printer will adjust automatic. It can adjust automatically in 3pcs and cleaning stencil automatically.



Industry 4.0 and MES

By automatically uploading or exporting the state and parameter, the intelligent production can be realized, the docking with customer MES system can be realized.



PCB Table Vacuum System

The PCB vacuum table can more stably fix the PCB on the platform to achieve high-quality fine-pitch PCB printing.



UPS

It can reduce the damage of the machine due to the failure of the power system caused by external reasons.



Stencil Flattener

The stencil and PCB positions are more stable during the printing process, improving the printing quality.

Materials List:

No.	Item	Brand	Original
1	Ball screw	KURODA, REXROTH	Japan, Germany
2	Linear Guideway	IKO, REXROTH	Japan, Germany
3	Servomotor&driver	Panasonic	Japan
4	Sensor	OMRON, LEUCE, KEYENCE	Japan
5	Stepper motor	SANYO, Leadshine	Japan, China
6	Cylinder	SMC, FESTO	Japan, Germany
7	CCD Camera	SENTECH	Japan
8	Software	I.C.T	China
9	Motor	BPMC	Japan
10	Switch	SMC, IDEC	Japan
11	Bearing	NSK	Japan
12	Soft Cable	IGUS	Germany
13	Tanks chain	IGUS	Germany
14	PC	LENOVO,DELL	China, Germany

Specification:

Model	I.C.T-4034	I.C.T-5134	I.C.T-5151	I.C.T-6534	I.C.T-6561	I.C.T-9060
Min Frame Size(mm)	470*370	470*370	470*370	650*400	650*400	737*400
Max Frame Size(mm)	737*737	737*737	737*737	850*750	850*850	1100*900
Frame Thickness	25~40mm					
Min PCB Size(mm)	50*50	50*50	50*50	50*50	80*50	80*50
Max PCB Size(mm)	400*340	510*340	510*510	650*340	650*610	900*600
PCB Thickness Adjustment	0.4~6mm(Option10~15)					
PCB Thickness	Manual Adjustment			Auto Table Adjustment for PCB Thickness		
PCB Warpage	<1%					
Transport Height	900±20mm					
Transport Direction	Left-Right; Right-Left; Left-Left; Right-Right					
Transport Speed	Max 1500mm/s					
Support System	Magnetic Pin/Up-down table adjusted/support block					
Clamping System	Side clamping(vacuum nozzle,Automation retractable Z pressure is option)					
Printer Head	Two independent motorised print head					
Squeegee Speed	10~200mm/sec					
Squeegee Pressure	0~15kg					
Squeegee Angle	60°/55°/45°					
Squeegee Type	Stainless steel standard(plastic is option)					
Squeegee Size	300&410mm	300&520mm	300&520mm	300&660mm	300&660mm	300&660mm
Release Speed	0.1~20mm/sec					
Cleaning System	Dry, Wet, Vacuum					

Table Adjustment	X: ±10mm; Y: ±10mm; θ: ±2°					
Inspection	2D Inspection(Standard)					
Repeat Accuracy	±0.01mm					
Printing Accuracy	±0.025mm	±0.025mm	±0.0125mm	±0.025mm	±0.025mm	±0.025mm
Cycle Time	<7s					
Product Changeover	<5Min					
Air Pressure	4.5~6Kg/cm ²					
Power Supply	AC 220±10%, 50/60HZ, 3KW					
Control Method	PC Control					
Operator system	Windows 10					
Dimension(mm)	1220*1355*1500	1220*1355*1500	1220*1550*1500	1330*1370*1500	1330*1545*1500	1580*1545*1500
Net Weight	1010kg	1010kg	1200kg	1100kg	1100kg	1400kg

Option Item:

No.	Item	No.	Item
1	Auto Solder Paste Supply	11	Air Knife at the entrance
2	Solder Paste Rolling Diameter Monitoring System	12	Temperature, Humidity Monitoring&Display+Temp. Control with External Aircon Unit
3	OPC Squeegee 2 pairs(300&450mm)	13	Squeegee Pressure Closed-loop Feedback System
4	Rubber Squeegee	14	UPS
5	Stencil Flattener	15	Grid-lock Support Block(200*40mm/block)
6	Stencil Hole Inspection System	16	PCB Cleaning Function
7	PCB Table Vacuum System	17	Internal &External Barcode Scanner for PCB Traceability
8	SPI Closed-loop	18	Handheld Barcode Scanner
9	Temperature, Humidity Monitoring &Display	19	Auto Table Adjustment for PCB Thickness
10	Auto Glue Dispensing	20	Stencil Y-direction Memory

Standard Accessories:

No.	Item	Quantity
1	Metal Squeegee	2 set
2	Operation Software	1 set
3	Cleaning Paper	5 roll
4	PCB Support Pin	26 pcs
5	PCB Support Block	6 pcs
6	Mixing knife	1 pcs
7	Fuse	1 pcs
8	Manual	1 book
9	Tool Case	1 set

* Attachments may change with product upgrade. If different, please follow the new list.

Consumables Spare Parts:

No.	Item	Usually replacement cycle
1	Transport belt	2 years
2	Transport pulley	2 years
3	Shaft limit sensor	1 years
4	Cylinder	2 years
5	Alcohol solenoid valve	1 years
6	Scraper blade	1 month
7	Cleaning paper	1 week

Dimensions:

I.C.T-4034/I.C.T-5134

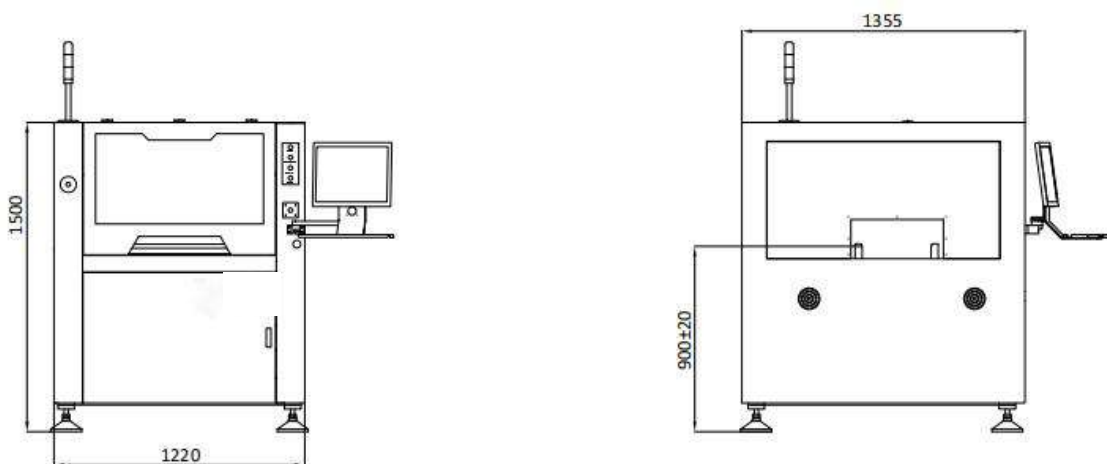

I.C.T-5151

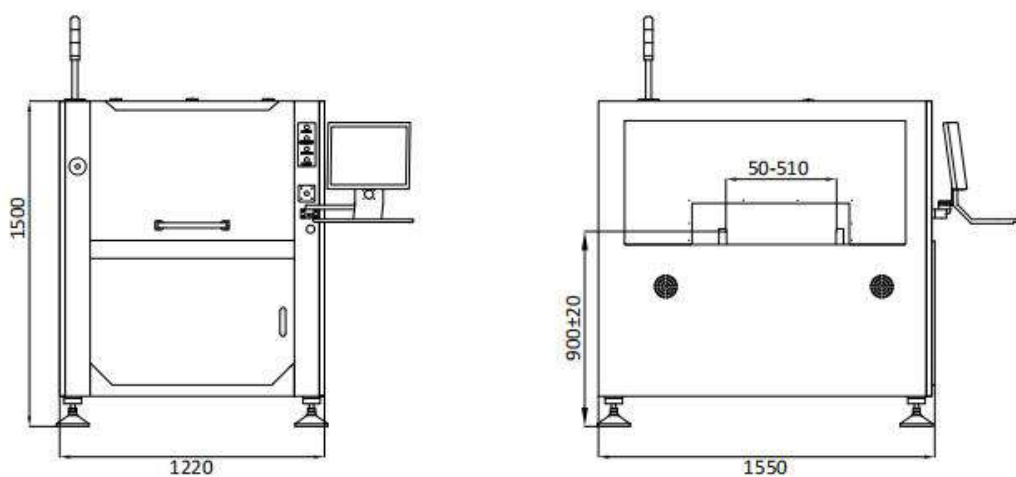

I.C.T-6534

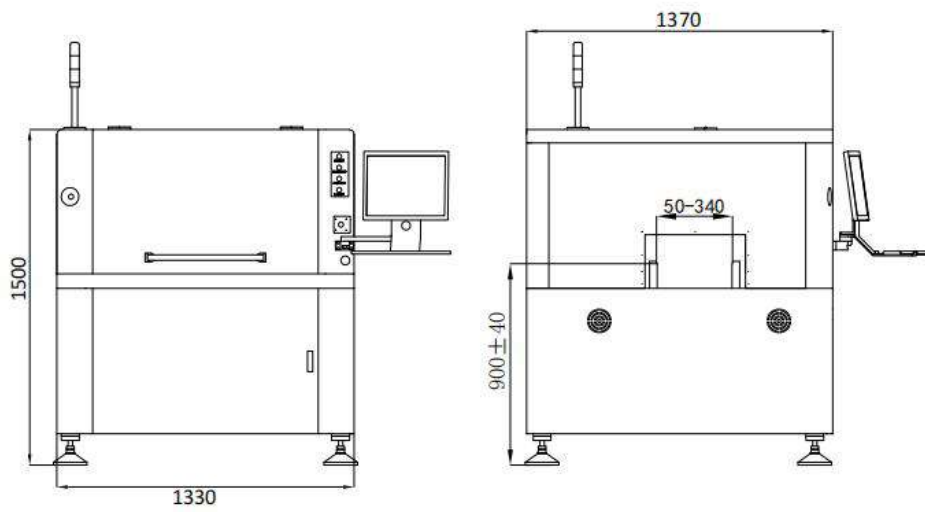

I.C.T-6561

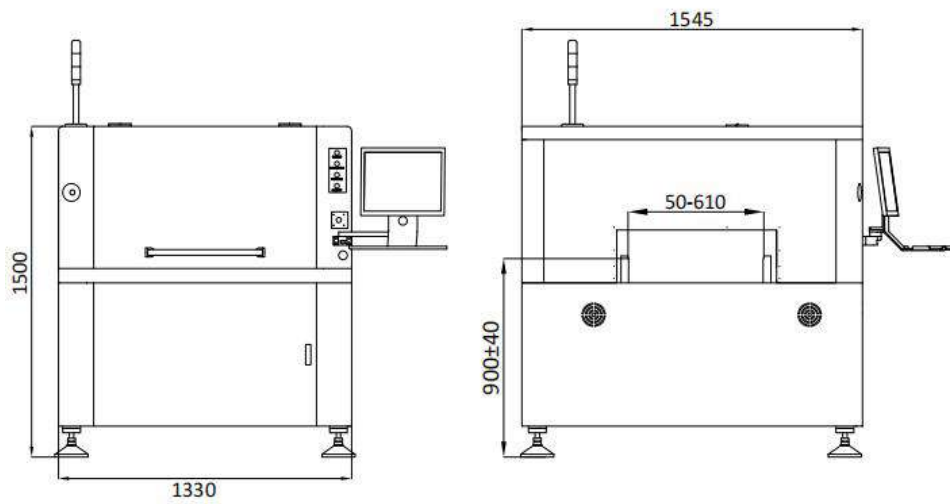

I.C.T-9060

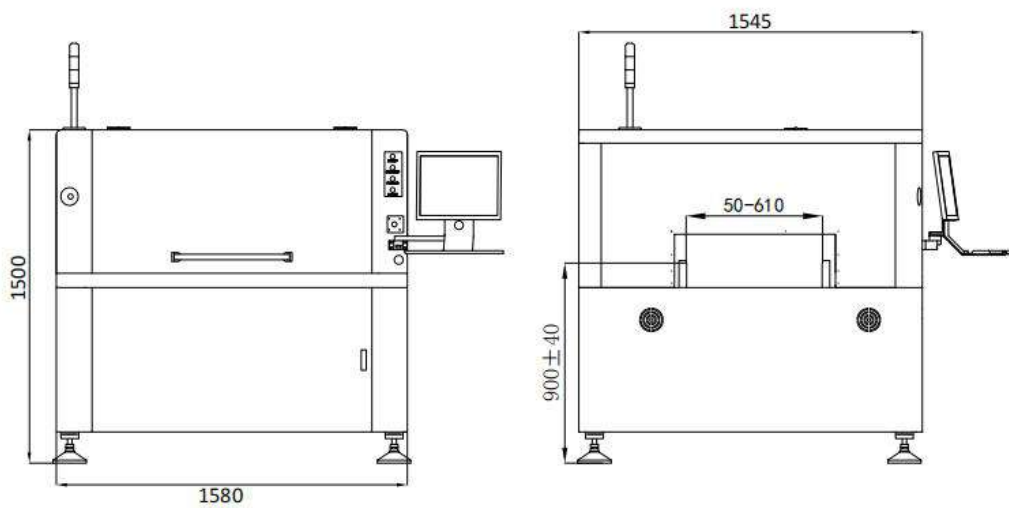

* I.C.T keeps working on quality and performance, specifications and appearance may be updated without particular notice.

Thanks for choosing I.C.T.

I.C.T looks forward to win-win cooperation.

Thank you.

