

USB TYPE-C PD3.0、QC3.0/2.0/MTK High Voltage Charger Protocol Controller

Feature

- **USB TYPE-C**
 - ✧ Integrate TYPE-C DRP protocol
 - ✧ Auto detect TYPE-C device plug in or plug out
 - ✧ Auto detect the capability of the sink and the source
- **USB Power Delivery (PD3.0)**
 - ✧ Hardware BMC transmitter and receiver
 - ✧ Full feature physical layer
 - ✧ Hardware CRC protect the data integrity
 - ✧ Integrate PD3.0 protocol engine
 - ✧ Support E-MARK cable
 - ✧ Support VCONN swap
 - ✧ Hardware reset
- **Integrate QC3.0/2.0 Quick charge protocol**
 - ✧ QC3.0/2.0 High voltage output protocol
 - ✧ CLASS A and CLASS B
 - ✧ Including BC1.2/APPLE/SUMSAMG charging protocol
 - ✧ Provide feedback voltage to adjust the output voltage dynamically
- **Support MTK PE+1.1 Fast charging technology**
- **Power Manage**
 - ✧ Build in VCONN power path switch
 - ✧ External P-MOSFET switch control
 - ✧ Build in ADC to monitor the current of the external MOSFET
 - ✧ Build in power path manage.
 - ✧ Power supply by VBUS or battery
 - ✧ Support application with no battery supply
- **ADC**
 - ✧ Build 14bit ADC
 - ✧ Monitoring Voltage and current of VBUS
 - ✧ Monitoring Voltage of the battery
 - ✧ Monitoring Voltage of the VCONN
 - ✧ Support 3 general ADC input
- **Peripheral interface**
 - ✧ SPI、I2C、UART、PWM、GPIOs
- **Low power consume**
 - ✧ Standby current less than 100uA
- **Package**
 - ✧ 5 mm × 5 mm QFN32

Applications

- ✧ AC power Adapter for cellphone, notebook, tablet, VR box, UAV, robot
- ✧ Power-Bank
- ✧ Car charger

Description

IP2716 is a highly-integrated, flexible high voltage charging protocol controller. It supports the most popular high voltage charging protocol. Such as TYPE-C PD3.0, QC3.0, MTK PE+1.1, DCP, BC1.2 etc.

The SOC could be a powerful protocol controller used in AC adapter, power-bank, Car charger or other power charging solution.

1. Logic Block Diagram

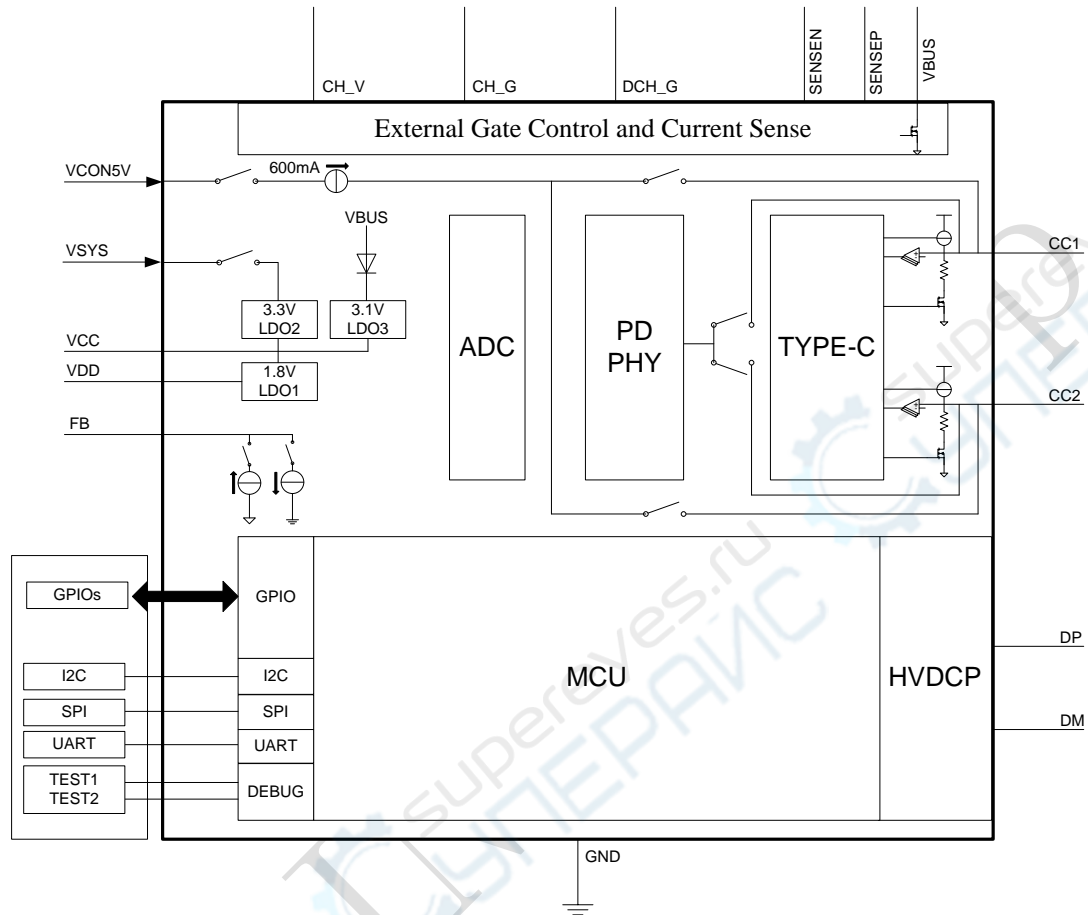

Figure 1 IP2716 Block Diagrams

2. Typical Application

Figure 2 illustrates a Notebook DRP application diagram using IP2716. The Type-C port can be used as a power provider or a power consumer.

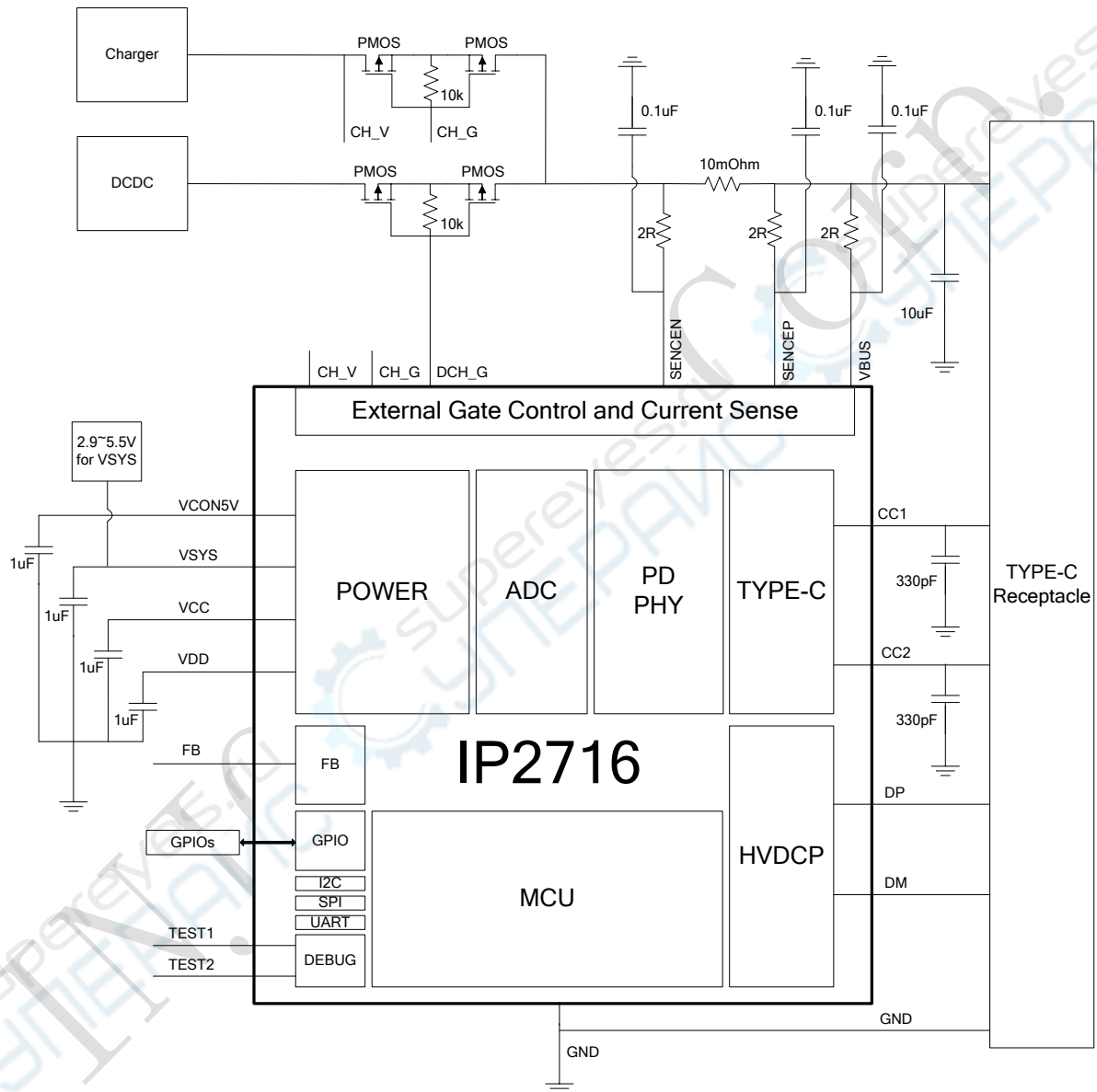

Figure 2 Dual Role Port (DRP) Application Diagram

Figure 3 illustrates the application diagram of power adapter using IP2716.

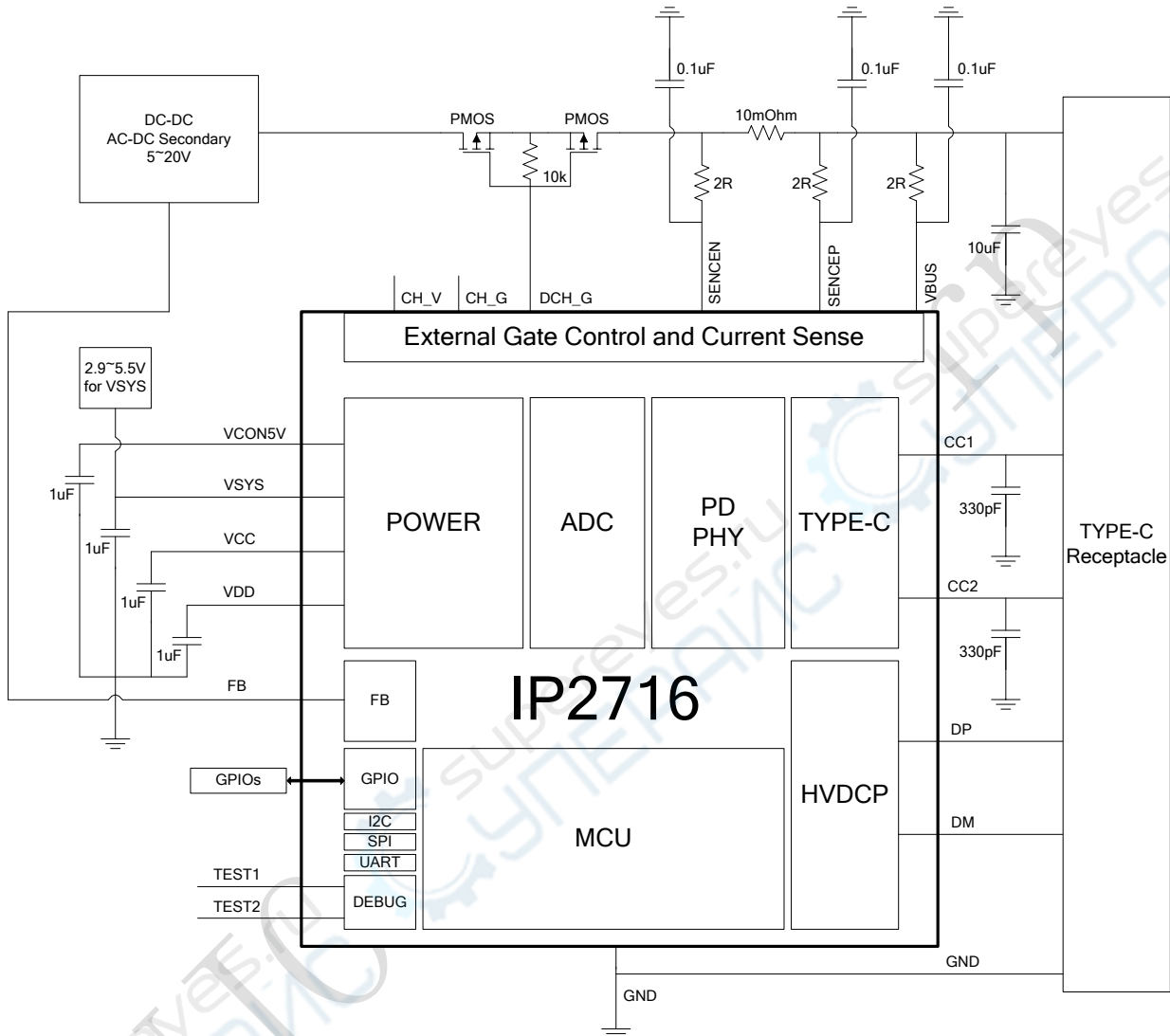

Figure 3 Power Adapter Application Diagram

Figure 4 illustrates a power bank application diagram using IP2716. The Type-C receptacle is used for providing as well as consuming power. Additionally, a Type-A receptacle can also be provided for providing power to the sinks

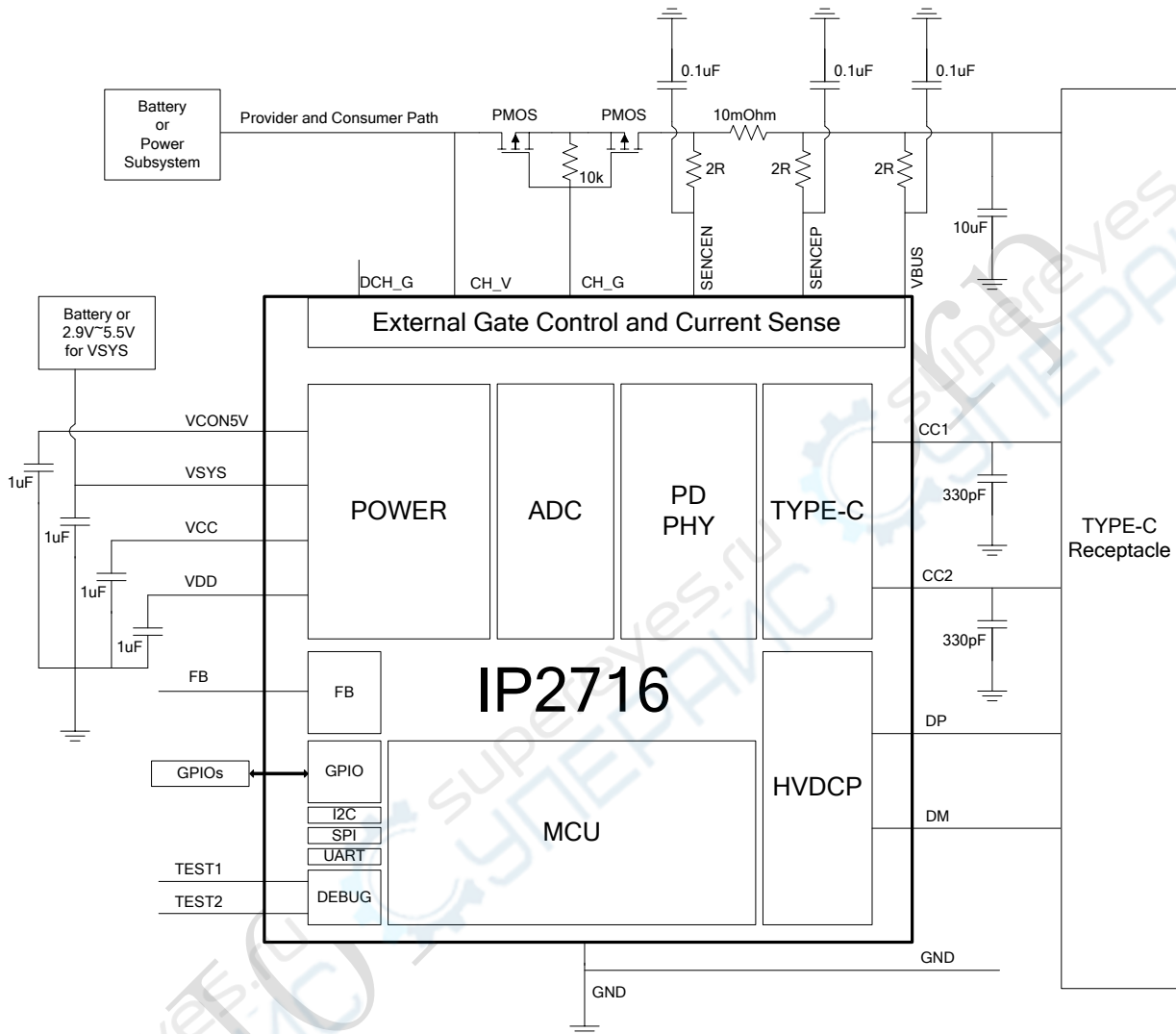

Figure 4 Power Bank Application Diagram

3. PINS

Table 1 IP2716 Pin Description for 32-QFN Devices

Pin Map 32-QFN	Pin Name	Description
1	SENSEP	connection point to the positive terminal of sense the VBUS current
2	SENSEN	connection point to the positive terminal of sense the VBUS current
3	CH_V	Used for voltage detection
4	CH_G	VBUS Gate Driver Control for Consumer Switch
5	DCH_G	VBUS Gate Driver Control for Producer Switch
6	VCON5V	5V supply for VCONN FETS
7	CC2	USB PD connector detect/Configuration Channel 2
8	CC1	USB PD connector detect/Configuration Channel 1
9	DM	USB DM
10	GPIO18	General Purpose Input / Output 18
11	GPIO17	General Purpose Input / Output 17
12	DP	USB DP
13	GPIO2	General Purpose Input / Output 2, ADC2, UART_RX
14	FB	Feedback loop drive output
15	GPIO8	General Purpose Input / Output 8, SPI_SS, UART_TX
16	GPIO7	General Purpose Input / Output 7, SPI_MOSI
17	GPIO9	General Purpose Input / Output 9, SPI_MISO
18	GPIO10	General Purpose Input / Output 10, SPI_CLK
19	TEST_1	Debug pin for programming the device and firmware update
20	GPIO5	General Purpose Input / Output 5, I2C_SDA
21	GPIO6	General Purpose Input / Output 6, I2C_SCL
22	TEST_2	Debug pin for programming the device and firmware update
23	GPIO4	General Purpose Input / Output 4, PWM6
24	GPIO1	General Purpose Input / Output 1, ADC1, PWM5
25	GPIO0	General Purpose Input / Output 0, ADC0
26	GND	Ground
27	GPIO15	General Purpose Input / Output 15
28	GPIO16	General Purpose Input / Output 16
29	VDD	VDD Supply Input / Output

30	VCC	VCC Supply Input / Output
31	VSYS	System Power Supply
32	VBUS	Input or output up to 20 V
33	EPAD (PGND)	Power Ground

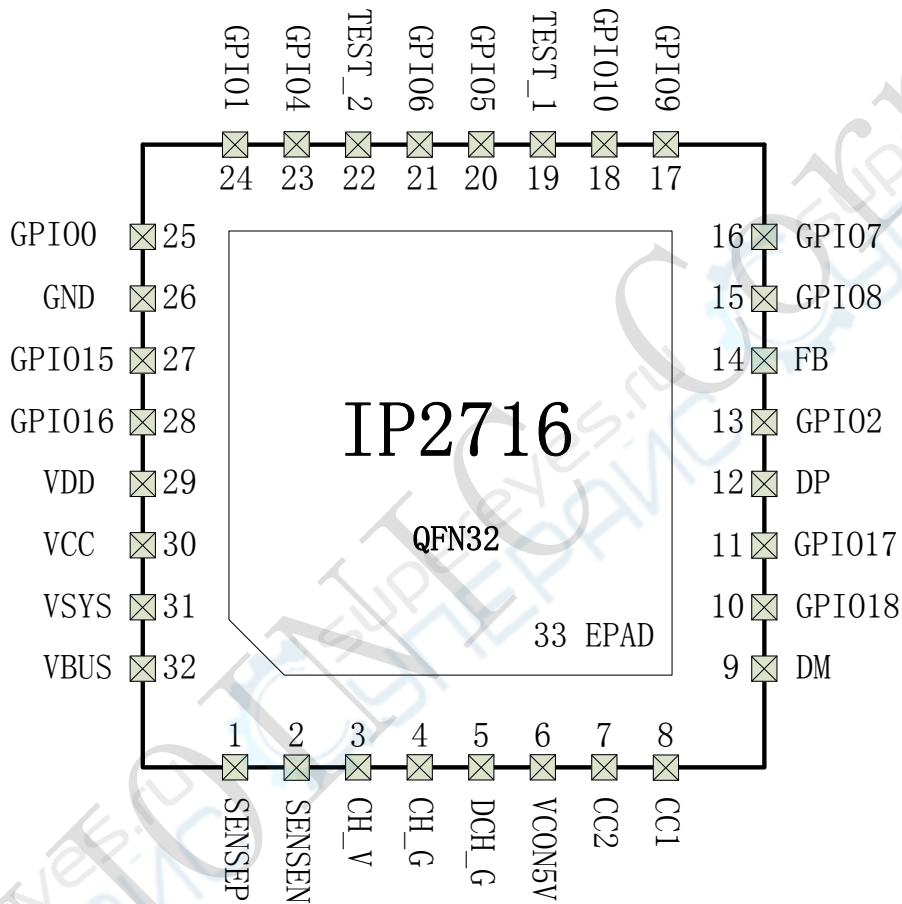

Figure 5 Pinouts of 32-QFN Package (Top View)

4. Specifications

4.1 Absolute Maximum Ratings

Parameter	symbol	MIN	MAX	UNIT
Input voltage range	VBUS	-0.3	24	V
	VCON5V	-0.3	6	
	VSYS	-0.3	6	
	VCC	-0.3	5	
	CH_V	-0.3	24	
	FB	-0.3	5	
	SENSEN	-0.3	24	
	SENSEP	-0.3	24	
Output voltage range	VCC	-0.3	3.3	V
	VDD	-0.3	2.2	
I/O voltage range	GPIOs	-0.3	VCC+0.3	V
	TEST1, TEST2	-0.3	VCC+0.3	
	CC1, CC2	-0.3	6	
	DP, DM	-0.3	6	
Junction temperature	T_J	-40	125	°C
Storage temperature	T_{stg}	-60	125	°C
Thermal resistance (from junction to ambient air)	θ_{JA}	18		°C/W
ESD		4000		V

*Stresses beyond those listed under absolute maximum ratings may cause permanent damage to the device. These are stress ratings only, and functional operation of the device at these or any other conditions beyond those indicated under recommended operating conditions is not implied. Exposure to absolute-maximum-rated conditions for extended periods may affect device reliability.

4.2 Recommend operation conditions

Parameter	symbol	MIN	Typical	MAX	Unit
Input voltage range	VBUS	4.5		22	V
	VCON5V	4.5		5.5	
	VSYS	2.9		7.4	
	VCC	2.8		3.3	
I/O voltage range	GPIOs	GND-0.3V		VCC+0.3V	V
	TEST1, TEST2	GND-0.3V		VCC+0.3V	
	CC1, CC2	GND-0.3V		5.5	
	DP, DM	GND-0.3V		5.5	

*Beyond these operation conditions, the device's performance will not be guaranteed

4.3 Electrical Characteristics

DC Specifications

Parameter	Description	MIN	TYP	MAX	Unit	Details/Test condition
VSYS		0		7.4	V	UFP Mode
VSYS		2.8		7.4	V	DFP/DRP Mode
VCON5V	Power Supply Input Voltage	4.5		5.5	V	
VCC			3.1		V	
VDD			1.8		V	
VBUS		4.5		22	V	

GPIO Specifications

Parameter	Description	MIN	TYP	MAX	Unit	Details/Test condition
VIH	Input voltage HIGH level	0.7x VCC			V	
VIL	Input voltage LOW level			0.3x VCC	V	
VOH	Output voltage HIGH level		VCC		V	
VOL	Output voltage HIGH level		GND		V	
Rpu	Pull-up resistor value		10		k	Pull-up resistor Enabled

TYPE-C DC Specifications

Parameter	Description	MIN	TYP	MAX	Unit	Details/Test condition
Rp_default	DFPCC termination for default USB Power		80		μA	
Rp_1.5A	DFP CC termination for 1.5A power		180		μA	
Rp_3.0A	DFP CC termination for 1.5A power		330		μA	
Rd	DFP CC termination for 1.5A power		5.1		kΩ	

I2C Specifications

Parameter	Description	MIN	TYP	MAX	Unit	Details/Test condition
F _{I2C}	Bit rate			400	KHz	

SPI Specifications

Parameter	Description	MIN	TYP	MAX	Unit	Details/Test condition
F _{SPI}	SPI Operating frequency			2	MHz	

UART Specifications

Parameter	Description	MIN	TYP	MAX	Unit	Details/Test condition
F _{UART}	Bit rate			384	KHz	

PWM Specifications

Parameter	Description	MIN	TYP	MAX	Unit	Details/Test condition
F _{PWM}	PWM Operating frequency			100	KHz	

ADC Specifications

Parameter	Description	MIN	TYP	MAX	Unit	Details/Test condition
Resolution	ADC resolution		14		Bits	
ADC _{VBUSV}	VBUS Voltage ADC range	0		24	V	
ADC _{VBUSI}	VBUS Current ADC range	-6.28		6.28	A	10mOhm
ADC _{VSYS}	VSYS Voltage ADC range	0		7.4	V	
ADC _{VCON5V}	VCON5V Voltage ADC range	0		7.4	V	
ADC _{0~2}	ADC _{0~2} range	0		3.7	V	

5. Function Description

5.1 Overview

USB-PD Controller

- Mode Configuration for Source (Host), Sink (Device), or Source-Sink
- Bi-Phase Marked Encoding/Decoding (BMC)
- Physical Layer (PHY) Protocol
- Policy Engine

USB TYPE-C Controller

- Detect USB Cable Plug Attach
- Cable Orientation and Role Detection
- Assign CC and VCONN Pins
- Advertise Default, 1.5A or 3A for TYPE-C Power

Power Switch

- Gate Control and Current Sense for External 5-V to 20-V, 5A Bi-directional Switch
- 5-V, 600mA Switches for VCONN
- Over-Current Limiter, Overvoltage Protector
- Slew Rate Control
- Hard Reset Support

Support Mainstream Fast Charge Mode

QC3.0, DCP, BC1.2, Pump Express Plus

Peripherals

I2C, SPI, UART, PWM

5.2 Power Delivery Over The USB Type-C Connector Using IP2716

Power delivery over the USB Type-C connector takes advantage of the existing USB methods as defined by: the USB 2.0 and USB 3.1 specifications, the USB BC 1.2 Specification and the USB Power Delivery specification. The USB Type-C Current mechanism allows the DFP to offer more current than defined by the USB BC 1.2 Specification. Additionally, IP2716 integrate QC3.0/2.0 Quick charge output Protocol, include BC1.2/APPLE/SUMSAMG charging protocol, Support MTK PE+ Fast charging technology.

5.3 USB Power Delivery Controller

The USB Power Delivery (PD) controller provides the physical layer (PHY) functionality of the USB-PD protocol. It is comprised of the following:

- Mode Configuration for Source (Host), Sink (Device), or Source-Sink
- Physical Layer (PHY) Protocol
- Policy Engine

Physical Layer (PHY) Functions

The USB PD Physical Layer consists of a pair of transmitters and receivers that communicate across a single signal wire (CC). All communication is half duplex. The PHY Layer practices collision avoidance to minimize communication errors on the channel.

The transmitter performs the following functions:

- Receive packet data from the protocol layer
- Calculate and append a CRC
- Encode the packet data including the CRC (i.e. the payload)
- Transmit the Packet (Preamble, SOP*, payload, CRC and EOP) across the channel using Bi-Phase Mark Coding (BMC) over CC

The receiver performs the following functions:

- Recover the clock and lock onto the Packet from the Preamble
- Detect the SOP*
- Decode the received data including the CRC
- Detect the EOP and validate the CRC
 - If the CRC is valid, deliver the packet data to the protocol layer.
 - If the CRC is not valid, flush the received data.

Policy Engine

Policy Engine interacts with the Device Policy Manager in order to implement the present Local Policy.

5.4 Detecting a Valid DFP-to-UFP Connection

For the USB TYPE-C solution, two pins on the connector, CC1 and CC2, are used to establish and manage the DFP-to-UFP connection. Functionally, the configuration channel is used to serve the following purposes.

- DFP-to-UFP attach/detach detection
- Plug orientation/cable twist detection
- Initial DFP-to-UFP (host-to-device) and power relationships detection
- USB Type-C VBUS current detection and usage
- USB PD communication
- Configure VCONN
- Discover and configure optional Alternate and Accessory modes

The general concept for setting up a valid connection between a DFP and UFP is based on being able to detect terminations residing in the product being attached.

To aid in defining the functional behavior of CC, a pull-up (R_p) and pull-down (R_d) termination model is used – actual implementation in hosts and devices may vary, for example, the pull-up termination could be replaced by a current source. (see **Figure 6**)

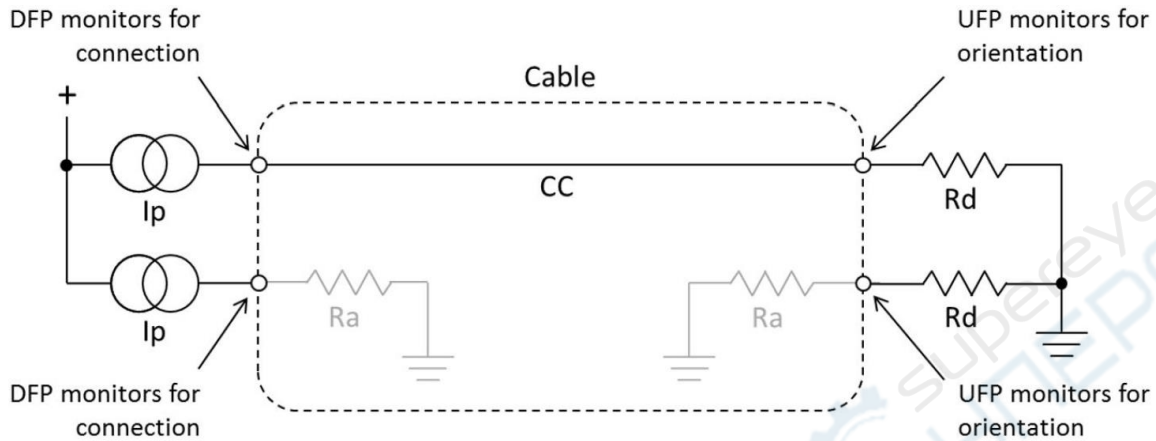

Figure 6 Current Source/Pull-Down CC Model

Figure 7 shows the IP2716 plug and orientation detection block at each CC pin.

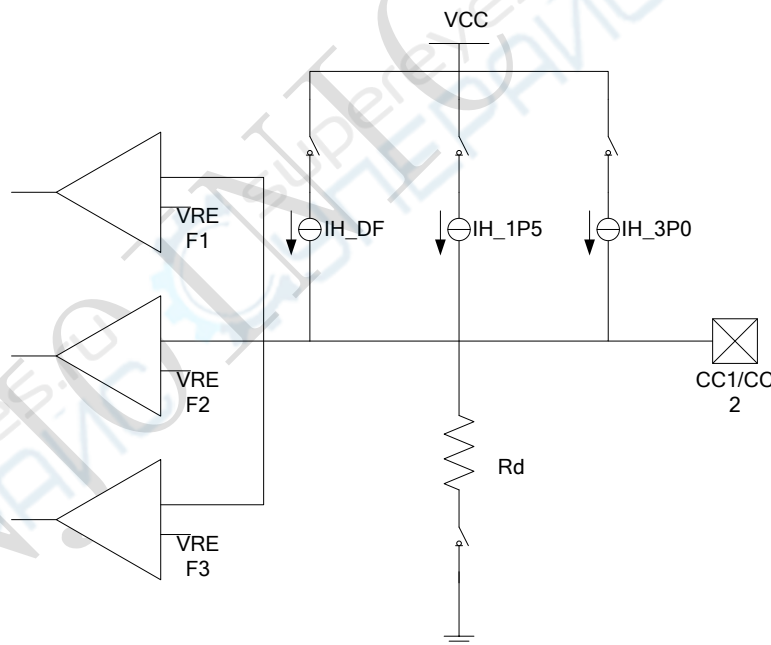

Figure 7 Plug and Orientation Detection Block

Configure as a DFP

When configured as a DFP, the IP2716 detects when a cable or a UFP is attached using the both CC pins. When in a disconnected state, the IP2716 monitors the voltages on these pins to determine what is connected.

Configure as a UFP

When the IP2716 is configured as a UFP, the IP2716 presents a pull-down resistance R_d on both CC pins. When the UFP senses V_{BUS} , the UFP monitors both CC pins for a voltage greater than its local ground. The CC pin that is at a

higher voltage (i.e. pulled up by Rp in the DFP) indicates the orientation of the plug. **Table 2** summarizes the port state from the DFP's perspective.

Table 2 Cable Detect States for a DFP

CC1	CC2	STATE	Source Behavior	Sink Behavior
Open	Open	Nothing attached	- Sense CC pins for attach - Do not apply VBUS or VCONN	- Sense VBUS for attach
Rd	Open	Sink attached	- Sense CC for orientation - Sense CC for detach - Apply VBUS and VCONN	- Sense CC pins for orientation - Sense loss of VBUS for detach
Open	Rd			
Open	Ra	Powered cable without Sink attached	- Sense CC pins for attach - Do not apply VBUS or VCONN	- Sense VBUS for attach
Ra	Open			
Rd	Ra	Powered cable with Sink or VCONN-powered Accessory attached	- Sense CC for orientation - Sense CC for detach - Apply VBUS and VCONN	- If accessories are supported, see Source Behavior with exception that VBUS is not applied., otherwise, N/A.
Ra	Rd			
Rd	Rd	Debug Accessory Mode attached (Appendix B)	- Sense CC pins for detach - Reconfigure for debug	- If accessories are supported, see Source Behavior, otherwise, N/A
Ra	Ra	Audio Adapter Accessory Mode attached (Appendix A)	- Sense CC pins for detach - Reconfigure for analog audio	- If accessories are supported, see Source Behavior, otherwise, N/A

Dead Battery Detection support

A system that supports Dead Battery Detection shall apply Rd to both CC pins. When the system with a dead battery has sufficient charge, it may use the USB PD DR_Swap message to become the DFP.

5.5 USB Type-C Current

The USB Type-C connector uses CC pins for configuration including an ability for a Source to advertise to its port partner (Sink) the amount of current it can apply:

- Default values defined by the USB Specification (500 mA for USB 2.0 ports, 900 mA for USB 3.1 ports)
- 1.5A
- 3.0A

A Sink that takes advantage of the additional current offered shall monitor the CC pins and shall adjust its current consumption to remain within the value advertised by the Source. While a USB PD contract is in place, a Sink is not required to monitor USB Type-C current advertisements and shall not respond to USB Type-C current advertisements.

The Source adjusts current source (or Rp) to advertise which of the three current levels it supports. (see **Table 3**)

Table 3 Source CC Termination (Rp) Requirements

Source Advertisement	Current Source to 1.7 – 5.5 V	Resistor pull-up to 4.75 – 5.5 V	Resistor pull-up to 3.3 V ± 5%
Default USB Power	80 μ A ± 20%	56 k Ω ± 20% (Note 1)	36 k Ω ± 20%
1.5 A @ 5 V	180 μ A ± 8%	22 k Ω ± 5%	12 k Ω ± 5%
3.0 A @ 5 V	330 μ A ± 8%	10 k Ω ± 5%	4.7 k Ω ± 5%

Table 4, Table 5 and Table 6 provide the CC voltage values that a Source shall use to detect what is attached based on what is attached based on the USB Type-C Current advertisement that the Source is offering.

Table 4 CC Voltages on Source Side – Default USB

	Minimum Voltage	Maximum Voltage	Threshold
Powered cable/adaptor (vRa)	0.00 V	0.15 V	0.20 V
Sink (vRd)	0.25 V	1.50 V	1.60 V
No connect (vOPEN)	1.65 V		

Table 5 CC Voltages on Source Side – 1.5 A @ 5 V

	Minimum Voltage	Maximum Voltage	Threshold
Powered cable/adaptor (vRa)	0.00 V	0.35 V	0.40 V
Sink (vRd)	0.45 V	1.50 V	1.60 V
No connect (vOPEN)	1.65 V		

Table 6 CC Voltages on Source Side – 3.0 A @ 5 V

	Minimum Voltage	Maximum Voltage	Threshold
Powered cable/adaptor (vRa)	0.00 V	0.75 V	0.80 V
Sink (vRd)	0.85 V	2.45 V	2.60 V
No connect (vOPEN)	2.75 V		

The voltage (Rd) on CC is used by the Sink to determine the maximum current it may draw. **Table 7** provides the CC voltage threshold on Sink side.

Table 7 Voltage on Sink CC pins (Multiple Source Current Advertisements)

Detection	Min voltage	Max voltage	Threshold
vRa	-0.25 V	0.15 V	0.2 V
vRd-Connect	0.25 V	2.04 V	
vRd-USB	0.25 V	0.61 V	0.66 V
vRd-1.5	0.70 V	1.16 V	1.23 V
vRd-3.0	1.31 V	2.04 V	

5.6 Support Mainstream Fast Charge Mode

Quick Charge Interface

The IP2716 can automatically detects Quick Charge 2.0/3.0 capable devices with handshake by USB D+/D- data line. It's also complaint with BC1.2 / APPLE 2.4A mode / Samsung Mode.

- Apple Device: Applying 2.7V on D+ line and 2.7V on D- line.
- Samsung Smart-Phone: Applying 1.2V on D+ line and 1.2V on D- line.
- BC1.2: Shorting D+ Line to D- Line.
- Quick Charge 2.0/3.0: D+ and D- line configuration see **Table 8**.

Table 8 QC2.0/3.0 DP/DM configuration

DP	DM	Result(Class A)	Result(Class B)
0.6 V	GND	5 V	5 V
3.3 V	0.6 V	9 V	9 V
0.6 V	0.6 V	12 V	12 V
0.6 V	3.3 V	Continue Mode	Continue Mode
3.3 V	3.3 V	Keep	20V

Pump Express Plus Protocol

The IP2716 is compatible with Pump Express Plus fast charge protocol 1.1. The Pump Express Plus Fast Charge protocol enables communication between devices.

5.7 Peripherals

IP2716 integrate Run-time reconfigurable serial communication block with reconfigurable I2C, SPI, UART and PWM functionality.

6. Package information

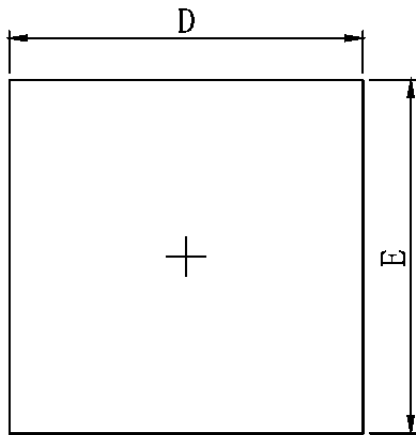

TOP VIEW

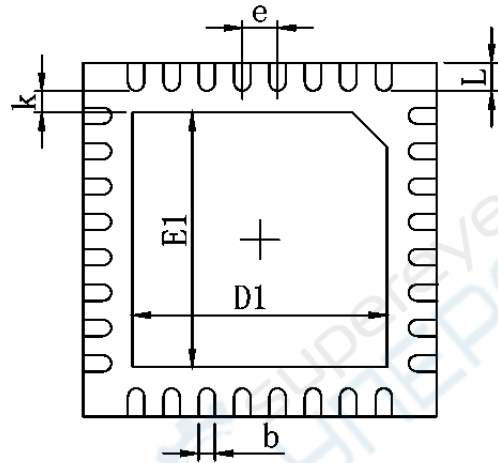

BOTTOM VIEW

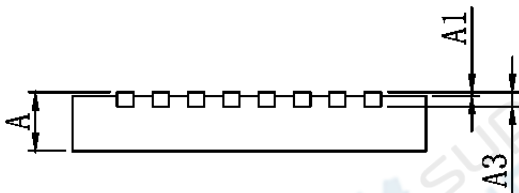

SIDE VIEW

Symbol	Dimensions In Millimeters		Dimensions In Inches	
	Min.	Max.	Min.	Max.
A	0.700	0.800	0.028	0.031
A1	0.000	0.050	0.000	0.002
A3	0.203REF.		0.008REF.	
D	4.924	5.076	0.194	0.200
E	4.924	5.076	0.194	0.200
D1	3.300	3.500	0.130	0.138
E1	3.300	3.500	0.130	0.138
k	0.200MIN.		0.008MIN.	
b	0.200	0.300	0.008	0.012
e	0.500TYP.		0.020TYP.	
L	0.324	0.476	0.013	0.019

IMPORTANT NOTICE

INJOINIC TECHNOLOGY and its subsidiaries reserve the right to make corrections, enhancements, improvements and other changes to its semiconductor products and services. Buyers should obtain the latest relevant information before placing orders and should verify that such information is current and complete. All semiconductor products (also referred to herein as “components”) are sold subject to INJOINIC TECHNOLOGY's terms and conditions of sale supplied at the time of order acknowledgment.

INJOINIC TECHNOLOGY assumes no liability for applications assistance or the design of Buyers' products. Buyers are responsible for their products and applications using INJOINIC TECHNOLOGY's components. To minimize the risks associated with Buyers' products and applications, Buyers should provide adequate design and operating safeguards.

Buyer acknowledges and agrees that it is solely responsible for compliance with all legal, regulatory and safety-related requirements concerning its products, and any use of INJOINIC TECHNOLOGY's components in its applications, notwithstanding any applications-related information or support that may be provided by INJOINIC TECHNOLOGY. Buyer represents and agrees that it has all the necessary expertise to create and implement safeguards which anticipate dangerous consequences of failures, monitor failures and their consequences, lessen the likelihood of failures that might cause harm and take appropriate remedial actions. Buyer will fully indemnify INJOINIC TECHNOLOGY and its representatives against any damages arising out of the use of any INJOINIC TECHNOLOGY's components in safety-critical applications.

Reproduction of significant portions of INJOINIC TECHNOLOGY's information in INJOINIC TECHNOLOGY's data books or data sheets is permissible only if reproduction is without alteration and is accompanied by all associated warranties, conditions, limitations, and notices. INJOINIC TECHNOLOGY is not responsible or liable for such altered documentation. Information of third parties may be subject to additional restrictions.

INJOINIC TECHNOLOGY will update this document from time to time. The actual parameters of the product may vary due to different models or other items. This document voids all express and any implied warranties.

Resale of INJOINIC TECHNOLOGY's components or services with statements different from or beyond the parameters stated by INJOINIC TECHNOLOGY for that component or service voids all express and any implied warranties for the associated INJOINIC TECHNOLOGY's component or service and is an unfair and deceptive business practice. INJOINIC TECHNOLOGY is not responsible or liable for any such statements.