

**SMT Fully Automatic LED Stencil Printer I.C.T 1200/1500**



**Introduce:**

I.C.T-1200/1500 LED is a high precision automatic solder paste printer, designed specifically for led and other large size products. Correspond to industrial 4.0 and MES system.through a higher level of automation, achieve zero defect.

**Printer:**



In 2021, More than 1900 sets of SMT automatic printing machines were sold. Sales volume SMT industry No.2



Many original patents, For example, cleaning system, dispensing system, then G company copy from I.C.T.

**Features:**

1. High positional accuracy, repeated positioning accuracy  $\pm 0.015\text{mm}$ ; printing accuracy  $0.03\text{mm}$ ;
2. Support glue printing, automatic control improves production efficiency, quality control and saves production cost;
3. Automatic PCB calibration, Squeegee pressure adjustable, Automatic printing, Automatic stencil cleaning;
4. Programmable motor controls separation speed and distance among squeegee, stencil and substrate, to realize multi-method separation;
5. Multi-functional PCB positioning system for convenient and accurate PCB positioning;
6. Programmable PCB lifting platform ensure the PCB to lift to a proper height;
7. Adopt company independently developed suspended print head with automatic pressure adjustment system. Support on-line real time pressure feedback and automatic squeegee pressure balancing. Accurate pressure control ensures perfect paste forming effect;
8. Applicable PCB types: LCD TV,LED,vehicle electronics.besides general electronics products;
9. SMEMA standard.

**TOP Advantage:**

1. Simple: Combined with advanced international concepts, based on the Oriental-designed operating system, easy to learn;
2. Expertise: Learn imported printer's advanced design concepts, and the machine core components are using imported top brands;
3. High Quality: Import hardware configuration,low failure rate in production,more than a decade service life;
4. Safety: Based on the general rules of international design, close to imported printer rating, the highest security level;
5. Stable: Mature software, hardware and top production processes ensures stability of each equipment.



**Print system**

Arch bridge suspension type direct connection squeegee structure. The squeegee is independently controlled by two high-precision stepping motors to ensure accurate and stable pressure. The double side slide positioning rails ensure the accuracy and stability of the squeegee before and after operation.



**Transport system**

The unique belt conveyor system can effectively prevent stuck PCB. The motor controls the speed and the stop position is precise. PCB entry and exit directions are freely available. The side clamps and vacuum are used to effectively clamp the PCB to ensure the smooth contact between PCB and stencil.

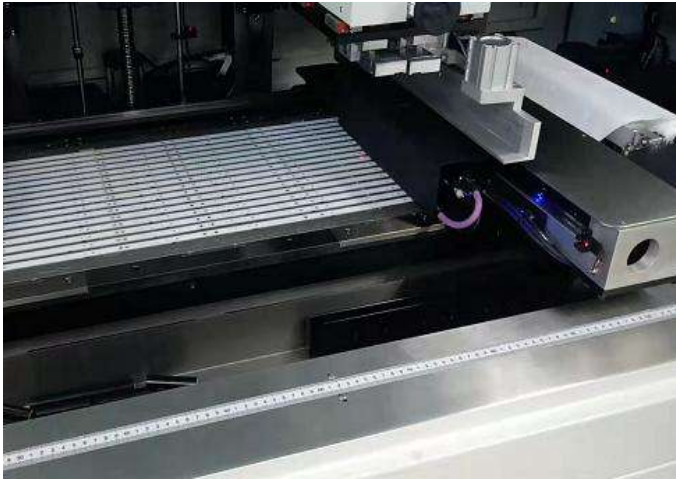

**Vision system**

Uniform ring and high brightness coaxial light source.  
Advanced up and down matching system. Full range light source adjust can identify various types of Mark.Suitable for tin plating, copper plating, tin spraying, FPC and other PCB to ensure high accuracy.



**Cleaning system**

Dry, wet cleaning, can also be manual cleaning; CCD and cleaning part are designed separately; Unique spray cleaning system, from top to bottom, spray evenly. Software control alcohol and paper consumption, save consumable. Special exhaust motor, vacuum strong and effective.

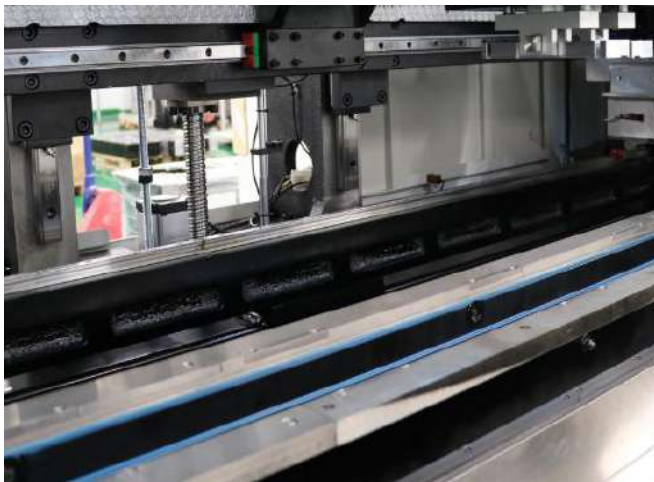

**Platform system**

The three axis linkage adjustment system has superb dynamic characteristics and quickly realizes the adjustment of PCB.Drive by direct connection motor, fast and ensure high precision.



**Operating System**

Windows 10,Friendly MMI interface, teaching and navigation function.Operation log, fault record analysis and other diagnostic functions.New program is controlled within 5-10 minutes.



**Option function:**



**OPC Squeegee**

Adjust printing area according to PCB size  
No stagnant solder paste, no wastage  
Best printing quality at all time.



**Rubber Squeegee**

Provides a rubber squeegee with better printing effect for the red glue process, which improves the quality.

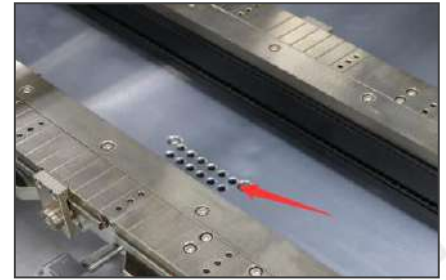

**PCB Table Vacuum System**

Fixed PCB is more stable, especially suitable for thin PCB and easily deformed PCB.

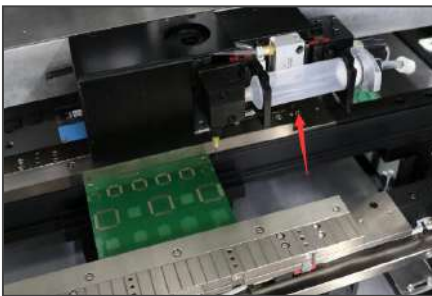

**Auto Glue Dispensing**

Program editing, used for component positions required for dispensing, and can also be used for red glue process for dispensing, making dual process possible.



**PCB Cleaning Function**

Clean the PCB entering the printing machine, clean the dust and other sundries on the surface of the PCB board, improve the printing quality and save costs.



**UPS**

It can reduce the damage of the machine due to the failure of the power system caused by external reasons, and provide continuous power guarantee for the machine.



**Grid-lock Support Block  
(200\*40mm/block)**

Provides a convenient printing support system for the production of double-sided PCBs, avoiding damage to the bottom components.

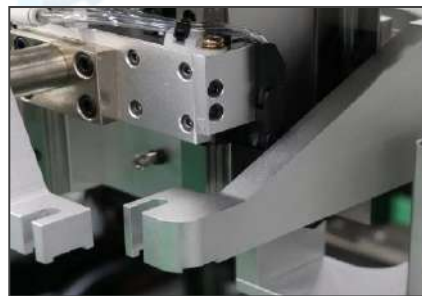

**Squeegee Pressure Closed-loop Feedback System**

For PCBs with high printing pressure requirements, the printing pressure can be adjusted in real time to ensure the printing quality.



**Internal & External Barcode Scanner for PCB Traceability**

Automatic design, record printed PCB code, better achieve traceability of machine product quality, and provide quality assurance.

**Materials List:**

No.	Item	Brand	Original
1	Ball screw	KURODA, REXROTH	Japan, Germany
2	Linear Guideway	IKO, REXROTH	Japan, Germany
3	Servomotor& driver	Panasonic	Japan
4	Sensor	OMRON, LEUCE, KEYENCE	Japan
5	Stepper motor	SANYO, Leadshine	Japan. China
6	Cylinder	SMC, FESTO	Japan, Germany
7	CCD Camera	SENTECH	Japan
8	Software	I.C.T	China
9	Motor	BPMC	Japan
10	Switch	SMC, IDEC	Japan
11	Bearing	NSK	Japan
12	Soft Cable	IGUS	Germany
13	Tanks chain	IGUS	Germany
14	PC	LENOVO,DELL	China,Germany

**Option Item:**

No.	Item	No.	Item
1	OPC Squeegee	7	Grid-lock Support Block
2	Rubber Squeegee	8	PCB Cleaning Function
3	PCB Table Vacuum System	9	Internal &External Barcode Scanner for PCB Traceability
4	Auto Glue Dispensing	10	Handheld Barcode Scanner
5	Squeegee Pressure Closed-loop Feedback System	11	AirKnife at the entrance
6	UPS		

**Specification:**

Model	I.C.T-1200	I.C.T-1500
Frame Size(mm)	737*300~1500*750	1100*300~1800*750
Frame Thickness	25~40mm	
PCB Size(mm)	80*50~1200*350	80*50~1500*450
PCB Thickness	0.4~6mm(Program settings, automatic adjustment)	
PCB Warpage	<1%	
Transport Height	900±20mm	
Transport Direction	Left-Right; Right-Left; Left-Left; Right-Right	
Transport Speed	Max 1500mm/s	
Support System	Magnetic Pin/Up-down table adjusted/support block	
Clamping System	Side clamping(vacuum nozzle, Automation retractable Z pressure is option)	
Printer Head	Two independent motorized print head	
Squeegee Speed	6~200mm/sec	
Squeegee Pressure	0~15kg	
Squeegee Angle	60°/55°/45°	

Squeegee Type	Stainless steel(standard), plastic	
Squeegee Size	300&410mm	
Release Speed	0.1~20mm/sec	
Cleaning System	Dry, Wet(Vacuum is Option)	
Table Adjustment Ranges	X: ±10mm; Y: ±10mm; θ: ±2°	
Table Adjustment control	Motor	
Mark Types	Circle, Triangle, Square, Diamond, Cross	
Mark Size	0.5~3.0mm	
CCD FOV	8*6mm	
Vision Methodology	CCD, Top and Bottom	
Repeated Accuracy	±0.015mm(CPK≥2.0)	
Printing Accuracy	±0.03mm(CPK≥2.0)	
Cycle Time	<15s(Exclude Printing&Cleaning)	<16s(Exclude Printing&Cleaning)
Product Changeover	<5Mins	
New Product Set-up Time	<10Mins	
Air Pressure	4.5~6Kg/cm <sup>2</sup>	
Power Supply	AC 220±10%, 50/60HZ, 3Kw	
Control Method	PC Control	
Dimension(mm)	L2200*W1200*H1500	L2500*W1200*H1500
Weight	Approx:1500kg	Approx:1800kg

\* The data is obtained under ambient temperature of 25℃ and humidity of 60%.

#### Standard Accessories:

No.	Item	Quantity
1	Metal Squeegee	2 set
2	Operation Software	1 set
3	Cleaning Paper	5 roll
4	PCB Support Pin	26 pcs
5	PCB Support Block	6 pcs
6	Mixing knife	1 pcs
7	Fuse	1 pcs
8	Manual	1 book
9	Tool Case	1 set

\* Attachments may change with product upgrade. If different, please follow the new list.

#### Consumables Spare Parts:

No.	Item	Usually replacement cycle
1	Transport belt	2 years
2	Transport pulley	2 years
3	Shaft limit sensor	1 years
4	Cylinder	2 years
5	Alcohol solenoid valve	1 years

6	Scraper blade	1 month
7	Cleaning paper	1 week

**Dimensions:**

**I.C.T-1200**

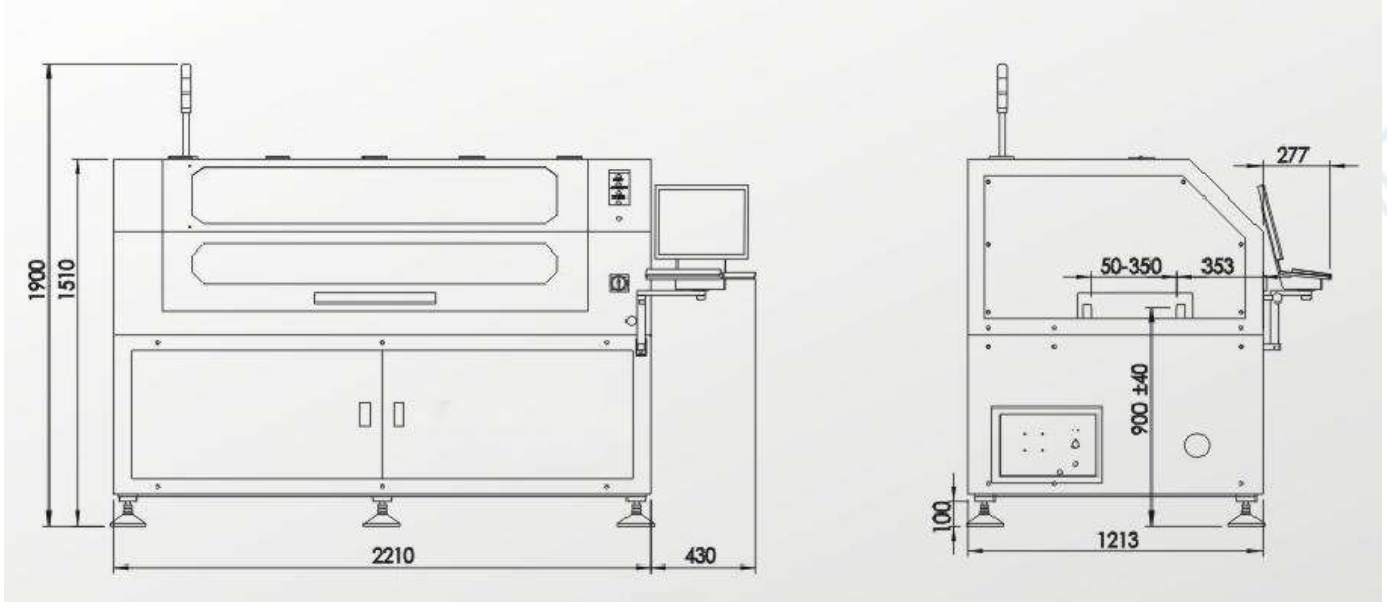

**I.C.T-1500**

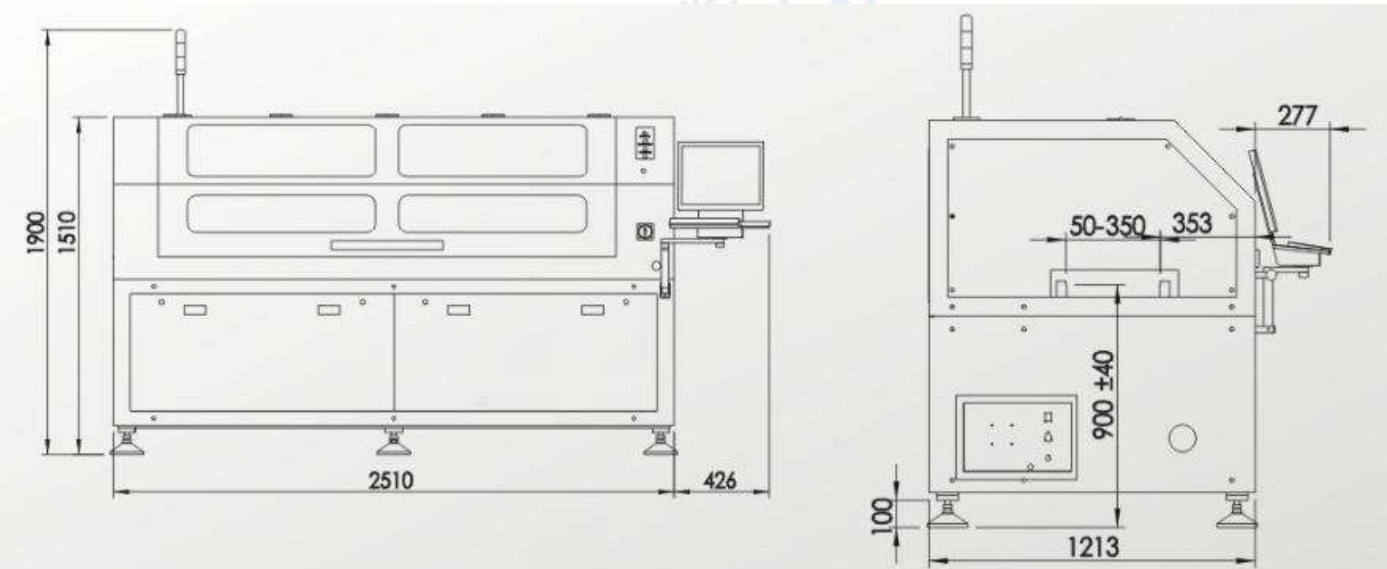

\* I.C.T keeps working on quality and performance, specifications and appearance may be updated without particular notice.

Thanks for choosing I.C.T.  
I.C.T looks forward to win-win cooperation.  
Thank you.