



# A15.1302

## Polarizing Microscope

# Instruction Manual



To ensure the safety and obtain satisfactory performance, please study this instruction manual thoroughly before start to use the instrument.

# Attention

**Read it carefully before operating and keep it with the microscope**

**Dear Sir or Madam:**

Thank you for using **A15.1302** series transmission polarizing microscopes. As one of the professional designers, manufacturers and distributors for optical instruments in China, since 1978, we have been working for supplying the new or old customers worldwide with high-quality and low-cost products. We wish that our products could bring you success and satisfaction. We enjoy offering you the most suitable products and the best service.

This manual gives a minute description of the structure, principle, configuration operating guide, troubleshooting, maintenance and some attention for **A13.1502** series transmission polarizing microscopes. Please read it carefully before you use, and keep it for long time.

In particular, the following notes must be understood thoroughly and obeyed strictly:

1. Permitted use:

Being high-precision laboratory apparatus, this microscope is not only used for polarizing microscopy observation, but also used for general biological microscopy observation.

2. No dismantle the equipment:

Unless you are a microscopic expert, or there is a special guide about doing so in the manual, please don't dismantle your microscope. Otherwise, it will damage the microscope seriously, and reduce greatly its accuracy and using-life. When you identify some troubles, and can't troubleshoot them by yourself according the manual, please contact us or our representative in you area.

3. Safety

----Before change a bulb, or need to open the base, ensure that the microscope has been disconnected with the power source. The new bulb must be the same specifications as the old one.

----When the illuminator is halogen lamp or incandescent lamp, the base near the lighting source may be very hot. Don't worry about it, but it must be treated carefully. Please take the combustible material (such as gasoline, paper, plastic and cloth) far away from the microscope.

----When change incandescent bulb or halogen bulb, wait until it is cool enough, otherwise the hot bulb will burn your fingers.

4. Use the correct power supply voltage

The power supply voltage must be fitted to the microscope; otherwise it will damage the circuit and bulb, even lead to insecurity.

5. Protecting optical parts

Never try to contact directly the optical surface of objectives, eyepieces and other optical parts with your finger. Fingerprints will seriously affect your observation results.

6. Don't leave any dust and fingerprints on the bulb, otherwise it may affect its life and illuminating efficiency.

7. Working surroundings requirements  
 Room temperature: 0°C-40°C  
 The highest relative humidity: 85%  
 High temperature and humidity can cause mildew and damage the instrument.
8. Microscope is a precision instrument, soft and gentle operation is necessary.  
 Any rude action or hard shake may damage it.

## INDEX

A) Application of Microscope .....	P.1
B) Structure and Specification of Microscope .....	P.1
1. Picture of Microscope .....	P.1
2. Structure Diagram of Microscope .....	P.2
3. Functions and Specifications of Parts .....	P.2
1) Micro-camera Components (Option Accessories) .....	P.2
2) Eyepiece .....	P.3
3) Viewing Head .....	P.3
4) Analyzer Part .....	P.3
5) Objective .....	P.3
6) Round Stage .....	P.3
7) Condenser .....	P.4
8) Plate for Numerical Aperture .....	P.4
9) Polarizer .....	P.4
10) Illumination System .....	P.4
11) Focusing System .....	P.4
C) Standard Outfit of Microscope .....	P.5
D) How to Use and Assemble .....	P.5
E) Maintenance and Care of Microscope .....	P.6

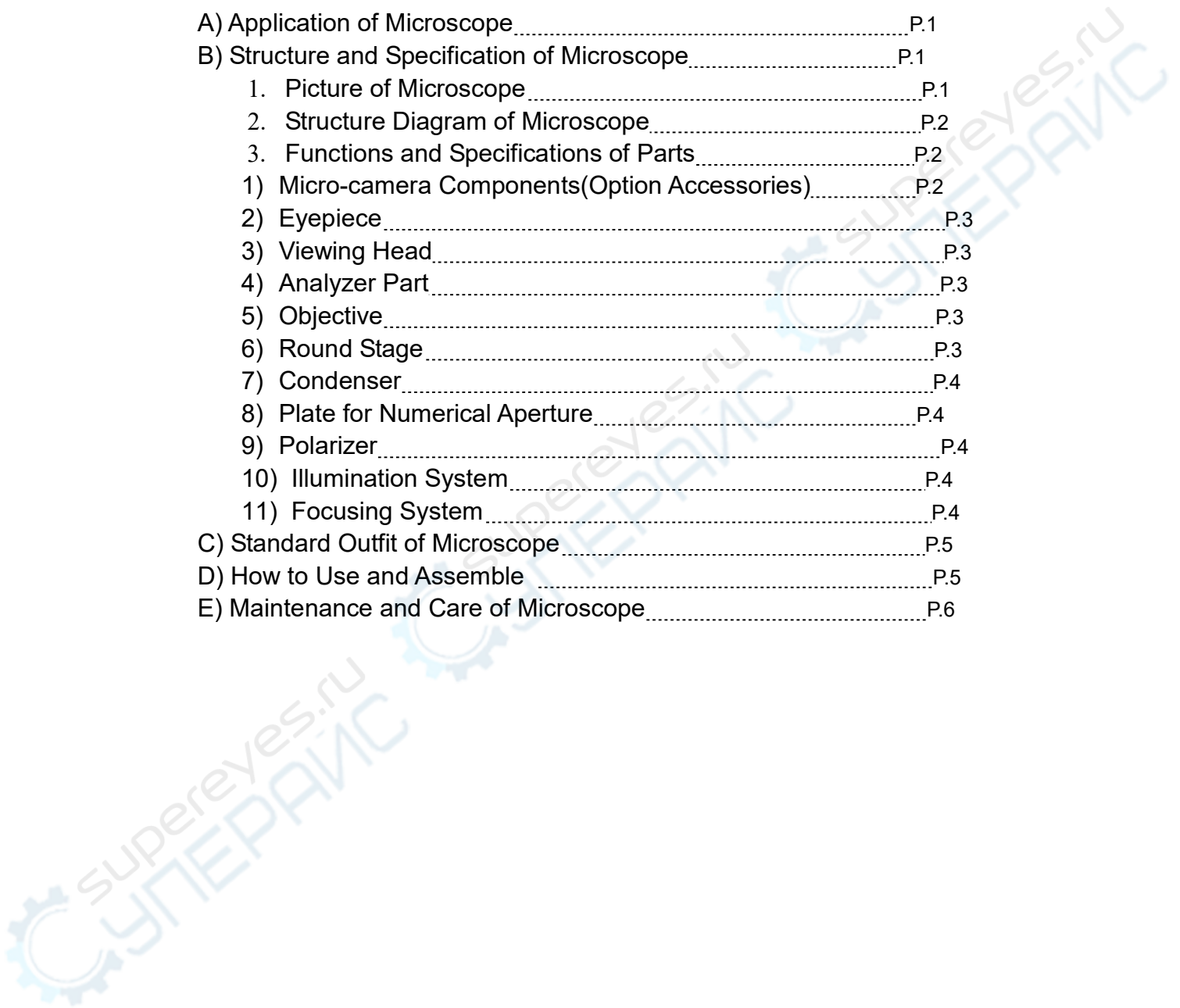

## A) Application of Microscope:

As the science and technology develops day and day, the technology applied in microscope is also more and more perfect. The application scope of the microscope is also continuing to expand.

A13.1502 series is a simple polarizing microscope with advanced multifunction. It can observe mineral crystal figure, color and interference color and also identify its optical performance. It is a good microscope used in geology, petroleum, coal, Chemical fiber, medical treatment and physic inspection. It is also widely used in academic demonstration and research.

$\lambda$  Slip (first class red), and  $1/4\lambda$  Slip make the microscope more perfect.

## B) Structure and Specification of Microscope:

### 1. Picture of Microscope:



Fig.1 A15.1302



Fig.2 Monocular

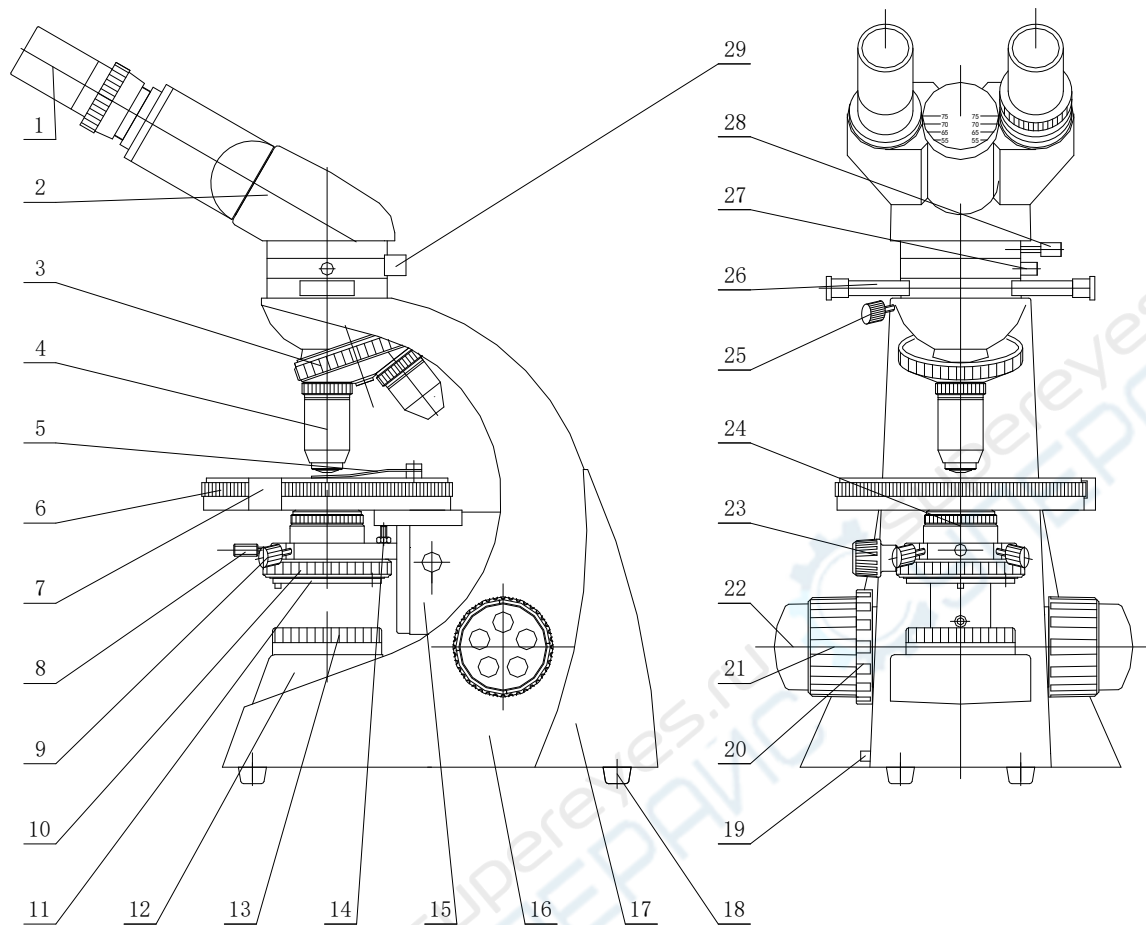

Fig.3 Dual



Fig.4 Trinocular

## 2. Structure Diagram of Microscope:



- |                                  |  |                          |
|----------------------------------|--|--------------------------|
| 1. Eyepiece                      | 2. Viewing Head                            | 3. Nosepiece             |
| 4. Objective                     | 5. Clips                                   | 6. Round Stage           |
| 7. Vernier Scale for Stage       | 8. Fix Screw for Condenser                 | 9. Centering Screw       |
| 10. Plate for Numerical Aperture | 11. Filter Frame                           | 12. Light Collector      |
| 13. Polarizer Plate              | 14. Screws for Stopping                    | 15. Support for Stage    |
| 16. Body                         | 17. Plastic Cover                          | 18. Rubber Foot          |
| 19. Brightness Adjusting Plate   | 20. Focusing Tension Knob                  | 21. Coarse Focusing Knob |
| 22. Fine Focusing Knob           | 23. Knob for Condenser Up/Down             | 24. ABBE Condenser       |
| 25. Lock Screw                   | 26. Compensator( $\lambda$ , $\lambda/4$ ) | 27. Rod for Analyzer     |
| 28. Lock Screw for Head          | 29. Analyzer                               |                          |

**Fig.5 Structure Diagram of Microscope YJ-2005BP**

## 3. Functions and Specifications of Parts:

### 1) Micro-camera Components (Option Accessories, Only for Trinocular Head):

If need, you may order from us: CCD Camera, or 1.3/3 million electronic eyepiece. It is used to put in micro-camera components or eyepiece. Its height is adjustable.

## 2) Eyepiece (1):

Type	Magnification	Diameter of Viewing Field(mm)	Quantity
Wide Field Eyepiece	10	18	2
Wide Field Eyepiece	16	13	(Optional)

## 3) Viewing Head (2):

It is a monocular, or dual, or binocular or trinocular head. Binocular or trinocular head is separated from the microscope body for transport safety. It is only fixed on the analyzer part with screw (28) before using. It is  $30^\circ$  /  $45^\circ$  inclined and  $360^\circ$  rotatable. Its interpupillary distance can be adjusted from 55mm to 75mm to suit for the different viewers. There is a rod for prism transition in the trinocular head. It is used to change the distribution of light. a) **In:** Light is totally transmitted in binocular tube, to ensure enough brightness when viewing. b) **Out:** The Spectroscope built-in divides the light into two parts. This moment, you may use the device in the vertical tube, such as CCD camera, electronic eyepiece, etc.

## 4) Analyzer Part:

It is comprised of analyzer and compensator. It is separated from the microscope body for transport safety. It is only fixed on the microscope body (16) with screw (25) before using.

When the microscope is only used for biological microscopy observation, put the compensator (26) on the middle position, and move the analyzer (27) out .

Insert the analyzer(27) in and drive the analyzer around the optical axis. Scale on the graduated ring and the vernier will tell you the angle analyzer turned.

You may select  $\lambda$  Slip (first class red), or  $1/4\lambda$  Slip to finish your special task.

## 5) Objective (4):

Normally, the objectives in this microscope are non-stress achromatic objectives:

Magnification	Numerical Aperture(N.A.)	Thickness of Cover Glass(mm)	Quantity
4	0.10		1
10	0.25		1
40	0.65	0.17	1
100	1.25	0.17	1

Total magnification after grouping eyepieces and objectives:

Objective Total Magnification Eyepiece	4	10	40	100
	WF10X	40	100	400
WF16X	64	160	640	1600

## 6) Round Stage (6) :

It is a revolving round stage, its diameter is 120mm, and it can  $360^\circ$  rotate freely. It is graduated in  $360^\circ$  area with  $1^\circ$  minimum increments. When vernier scale (7) is used, the revolving angle precision of the stage is  $0.1^\circ$  .

Usually, the sample is put on the stage under the clips (5).

#### **7) Condenser (24):**

Revolve the knob (23), the gear-rack mechanism makes the condenser up or down to suit for the different objectives.

#### **8) Plate for Numerical Aperture (10):**

The numerical aperture of the iris diaphragm built-in can be adjusted from  $\text{Ø}2\text{mm}$  to  $\text{Ø}30\text{mm}$  by turning the plate (10). When the diameter of iris diaphragm is 70-80% of the objective's numerical aperture, the image observed is sharp in contrast. This moment, look into the tube without eyepiece, and you can see the image of iris diaphragm. The center of the diaphragm can be adjusted by rotating the black-head screws (9) without any tools as following steps:

- a) Turn the 4X or 10X objective in working;
- b) Turn the plate (10) to small the diaphragm diameter;
- c) Lower the diaphragm to make its image sharp by rotating the knob (23);
- d) Rotate the screws (9) to centre the image of the diaphragm with the eyepiece viewing field.

Usually, it is adjusted coaxial before the microscope is finished.

#### **9) Polarizer Plate (13):**

The position of the polarizer in microscope is fixed. Turn the plate (13), the deflexion angle of the polarizer will change. Scale on the graduated ring will tell you the angle the polarizer turned.

#### **10) Illumination System:**

The input voltage for the microscope may be 220V/50Hz, or 110V/60Hz. So you should make sure which voltage is used during purchasing. At same time you should tell us the plug type of the electrical wire.

The illuminator is normally 6V/20W halogen lamp. If you need, we also provide you 3.5V/1W high brightness LED lamp.

##### **Caution:**

**----Before change a bulb, ensure that the microscope has been disconnected with the power source;**

**----The bulb must be the same specifications as the old one;**

**----When the illuminator is halogen lamp, the body near the lighting source may be very hot. Don't worry, but it is necessary to take the combustible material (such as gasoline, paper, plastic and cloth) far away from the microscope. When change it, wait until it is cool enough. Otherwise the hot bulb will burn your fingers.**

**----Don't leave any dust and fingerprints on the bulb. Otherwise it may affects its life and illuminating efficiency.**

#### **11) Focusing System:**

It is coaxial coarse and fine focusing system with rack and pinion mechanism. Its focusing range is 15mm. Decelerate through the multistage precision gear box, its precision of fine focusing is 0.01mm/scale.

Rotate the coarse focusing knob (21) to raise the stage (6) up/down quickly. Rotate the fine focusing knob (22) to raise the stage (6) up/down slowly. The knob (20) is used to adjust the coarse focusing moment. It will avoid the stage dropping automatically because of its deadweight and provide comfortable operating.

### C) Standard Outfit of Microscope:

No.	Item	Quantity	Remark
1	Main body of A13.1502 transmission polarizing microscopes	1Set	
2	Viewing head	1Set	
3	Analyzer part	1Set	
4	Polarizer Plate	1Set	
4	Non-stress achromatic objective		
	4X/0.10	1Pcs	
	10X/0.25	1Pcs	
	40X/0.65 Spring	1Pcs	
	100X/1.25 Spring	1Pcs	
6	Wide field Eyepiece		
	WF10X/18 Wide field Eyepiece	2Pcs	
	WF16X/13 Wide field Eyepiece	Optional	
7	$\lambda$ Slip (first class red)	1Pcs	
8	$1/4\lambda$ Slip	1Pcs	
9	Blue filter	1Pcs	
10	Fuse	1Pcs	
11	Dust cover	1Pcs	
12	Service Manual	1Copy	
13	Spare bulb	1Pcs	Only for Halogen Lamp

### D) How to Use and Assemble:

1. Working surroundings requirements:
  - 1) Room temperature: 0°C-40°C, The highest relative humidity: 85%
  - 2) High temperature and humidity can cause mildew and damage the instrument.
  - 3) Keep the microscope away from dust. When it's not used, put the dust cover over it;
  - 4) keep the microscope away from vibration;
2. Unpack the microscope and its parts carefully, check and sort out all parts according to the packing list. Finally install the analyzer part, viewing head, objectives and eyepiece to the main body as the structure diagram of Microscope.
3. Connect the microscope to the power source according to its input requirement. Turn on the switch,



**Caution:**

**If the power supply voltage is not fitted to the microscope, it will damage the circuit and bulb, even leads to insecurity.**

**4. Focusing:**

Put the sample on the stage, and place a lower objective (4X) into position. Raise the stage close to the sample by rotating the coarse focusing knob (21) in the anticlockwise direction. Then rotate the coarse knob (21) slowly in the clockwise direction, until the image appears in the eyepiece. At last, use the fine focusing knob (22) to make the image in focus. Rotate the nosepiece (3) to other objectives and focus. Since the optical system in the microscope is par-focal and par-centered, only slightly turn the fine focusing knob (22) to make the image in focus.

**5. How to adjust the center of the Numerical Aperture:**

Place the lower objective (4X) into position, and insert a eyepiece with crosshairs. Turn the plate (10) to small the diameter of the diaphragm, and rotate the knob (23) to move the diaphragm up or down until the diaphragm in focus. Adjust the black-head screw (9) to centre the image with the center of the eyepiece viewing field.

**7. How to observe in orthogonal polarizing condition:**

1) Make the analyzer is orthogonal with the polarizer. The analyzer is in south-north, and the polarizer is in east-west.

2) The condenser is usually in lower position when 4X or 10X objectives is used; and higher position when 40X , or 100X objective is used.

3) Select  $\lambda$  Slip (first class red), or  $1/4\lambda$  Slip,

**E) Maintenance and Care of Microscope:**

1. Unpack the microscope carefully to prevent the accessories such as lens from falling down and damaging.

2. All lens are calibrated, don't try to dismantle them apart by yourself.

3. Nosepiece and focusing system are advanced and precise in construction. Don't try to dismantle them apart by yourself. Please connect with an authorized technician when they are in trouble.

4. Keep the mechanical parts from dust, and add a few no-corrosiveness lubricating grease into the sliding sections at regular intervals. Keep the optical elements clean when wipe the microscope.

5. Keep the microscope in dry and cool place. Disconnect it with the power source and put the dust cover over it after using. If it will be not used for a longer time, it is the best way to screw the objectives out and place them into the lens-bottles, and screw the dust covers on the nosepiece.