



A16.2603-L

LED Fluorescent Microscope

Instruction Manual



To ensure the safety and obtain satisfactory performance, please study this instruction manual thoroughly before start to use the instrument.

Content

⚠️	Attentions	2
1.	Performance & parameter	3
2.	Parts name	4
3.	Installation and carry	6
3.1	Summarize	6
3.2	Installation Steps	7
3.2.1	Installation of Eyepiece tube	7
3.2.2	Installation of Eyepiece	7
3.2.3	Installation of Accessory Box	8
3.2.4	Installation of Objective	8
3.2.5	Installation of Condenser	8
3.3	Carry	8
4.	Operation	9
4.1	Operation Process instruction	9
4.2	Methods for Bright Field Observation	10
Step 1	Switching on the power	10
Step 2	Place sample	10
Step 3	Focusing with 10x objective	11
Step 4	Adjustment of interpupillary distance and diopter	11
Step 5	Adjustment of condenser aperture diaphragm	12
Step 6	Adjustment of field diaphragm and centring	13
4.3	Use of Immersion objective	14
4.4	Matters need attention after use	14
5.	Installation and use of accessory	15
5.1	Filter	15
5.2	Polarizing Unit	15
5.3	Dark Field Unit	16
5.4	Phase Contrast Unit	17
6.	Installation and use for digital camera and photographic device	20
7.	Installation and use for fluorescence device	24
7.1	Parts name	25
7.2	Installation	26
7.3	Operational parts name	27
7.4	Operation of fluorescence unit	28
7.5	Use of centring device	30
8.	Maintenance	31
8.1	Clean	31
8.2	Usage environment and storage	31
8.3	Replacement of halogen bulbs	32
8.4	Replacement of fluorescence mercury lamp	34
8.5	Replacement of fuse tube	36
8.6	Storage	36
	Appendix 1: Troubleshooting	37
	Appendix 2: Transport environment	38
	Appendix 3: Identifier meaning	38

Attentions ! !

1. Purpose

This series microscope is used only for microscopic observation, not available for other purpose, otherwise result in equipment damage.



2. Disassembly only by the professionals

The microscope has been adjusted before shipping, Unprofessional-person should not disassemble and remove any other parts. Disassemble and remove any other parts will result in equipment damage .

If you have any questions, please contact with manufacturer or local distributor.

3. Note the input voltage if correspond

This instrument designed for wide input voltage (100V~240V, 50/60HZ), applicable to most area .But if the supply voltage exceeds this range, the instrument will be seriously damaged.

4. Prevent Burns And Fire

When using power equipment, bulbs and collecting mirror and other nearby parts of the set will rise sharply in temperature until it reaches a thermal equilibrium state. Pay attention to anti-hot logo, they should be careful not be burn when in use.

Alcohol, gasoline, paper and other flammable materials can't near the lamp in case of fire.



5. Notes On Replacing The Bulb

Replacement should be based on the identity of the instrument using the same specifications of the bulb, otherwise it may cause equipment damage.

The power supply must be cut off before bulb replacement, the bulb must be cooled off completely before proceeding! !



6. Carry

Power must be cut off before moving. Be careful not to crush your finger when placed.

This instrument is a precision instrument, and it should be handle with care, severe shock can cause serious damage to equipment-related parts.

7. Installation

Please refer to the installation instruction in order to avoid to damage the instrument .

8. Operation Environment

The required available environment for using of the equipment:

Indoor temperature: 0 °C ~ 40 °C

Maximum relative humidity: 85%

High temperature or high humidity may cause mildew, fog or dew of the optical components, and make the instrument not work.

9. Packing Waste Disposal

For the protection of the environment, please properly handle the microscope packing waste or send to salvage station (such as cardboard, foam, etc.)



1. Performance Parameter

1.1 Total Magnification

Objective Eyepiece	2.5×	4×	10×	20×	40×	60×	100×
10×	25×	40×	100×	200×	400×	600×	1000×

1.2 Objective (with 10X Eyepiece, subject to standard outfit)

Infinity Plan Achromatic Objective	Numerical Aperture N.A.	Objective Field (mm)	Resolution (μm)	Working Distance (mm)
		Field $\phi 22$		
2.5×	0.07	8.8	4.79	8.47
4×	0.10	5.5	3.35	12.1
10×	0.25	2.2	1.34	4.64
20×	0.40	1.1	0.84	2.41
40×(S)	0.66	0.55	0.51	0.65
60×(S)	0.80	0.37	0.42	0.33
100×(S,O)	1.25	0.22	0.27	0.19
100×(S,W)	1.15	0.22	0.29	0.19

2. Parts Name

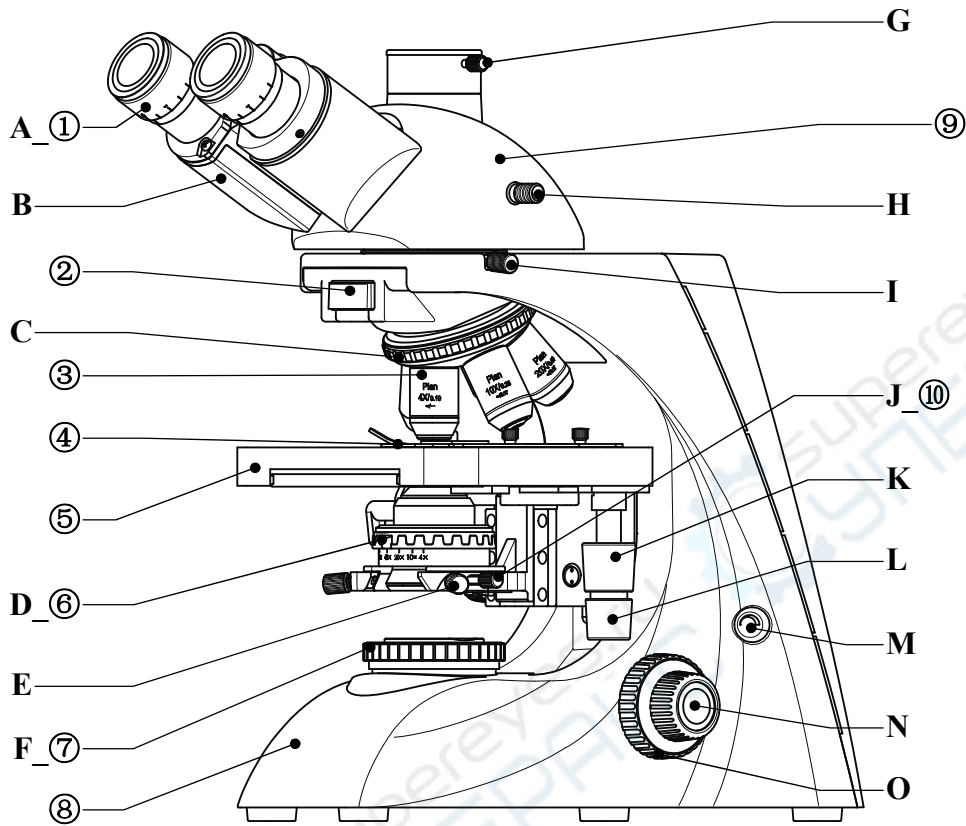

Fig.2-1

Component Parts Name:

- | | | |
|-------------------------|------------------------|-------------------------------|
| 1. Eyepiece | 5. Integrated stage | 9. Seidentopf trinocular head |
| 2. Accessory module box | 6. Swing-out condenser | 10. Condenser holder |
| 3. Objective | 7. Field diaphragm | |
| 4. Clamps | 8. Main body | |

Operable Parts Name:

- | | | |
|--|---|---|
| A. Diopter adjusting ring | G. C-mount screw | L. Horizontal adjusting hand wheel |
| B. Eyepiece tube | H. Trinocular lever | M. Brightness adjusting knob |
| C. Nosepiece | I. Observing tube locking screw | N. Right fine focusing knob |
| D. Aperture diaphragm lever | J. Condenser locking screw | O. Right coarse focusing knob |
| E. Field diaphragm centring lever | K. Vertical adjusting hand wheel | |
| F. Field diaphragm lever | | |

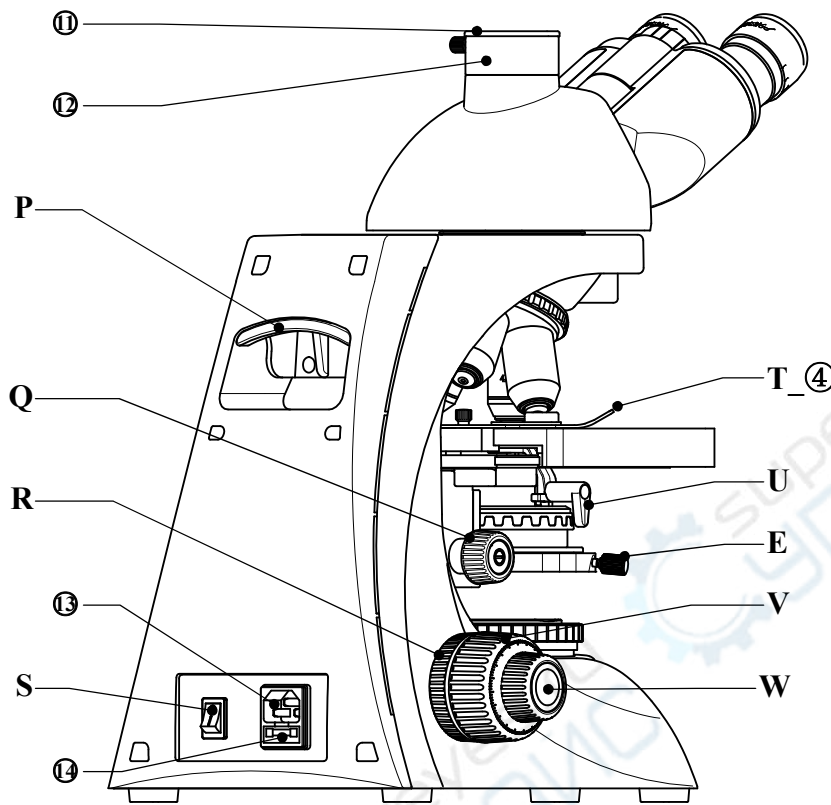

Fig.2-2

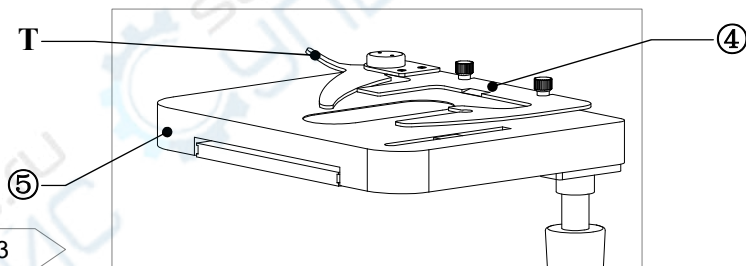

Fig.2-3

- 11. Cover
- 12. Trinocular tube

- 13. Power input
- 14. Fuse

- P. Handle
- Q. Adjusting knob for condenser
- R. Coarse tension focusing knob
- S. Power switch

- T. Switch for clamps
- U. Adjustable lever for swing-out condenser
- V. Right coarse focusing knob
- W. Left fine focusing knob

3. Installation and Carry

3.1 Summarize

Please clean the operation desk before installation, such as paper, cotton, alcohol or garbage , in case for danger.

Make sure the input voltage meets input socket's requirement (AC100~240V,50/60Hz) and the power switch is in OFF.

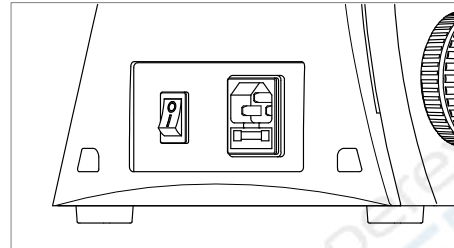

Fig.3-1

★ Please following chart steps for installation:

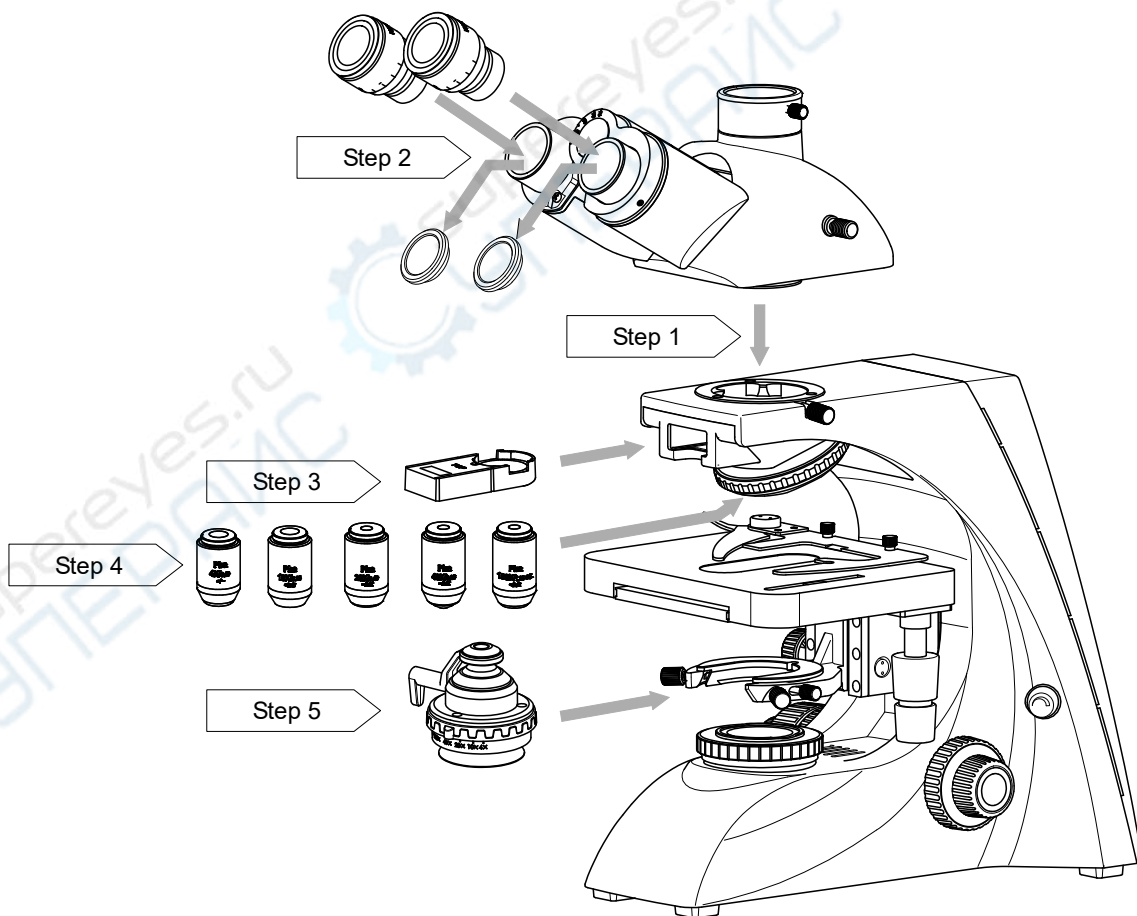

Fig.3-2

3.2 Installation Steps:

3.2.1 Installing Binocular Head

Loosen Locking screw for observing tube I (not unscrew completely), take seidentopf trinocular head out, then jointing seidentopf trinocular head's taper connective base(Fig. 3-3) and connective hole which on the stand top(Fig. 3-4). Finally, adjusting eyepiece tube direction, locking screw (I) and fixing the trinocular head .

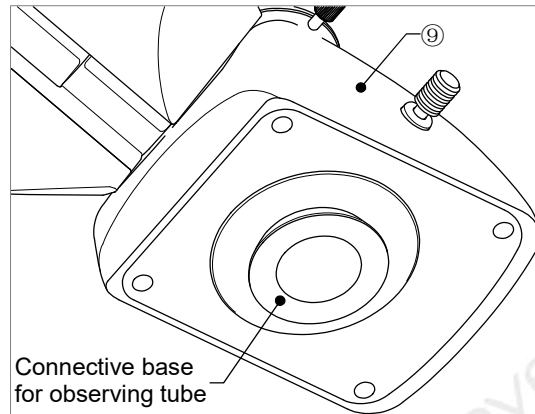

Fig. 3-3

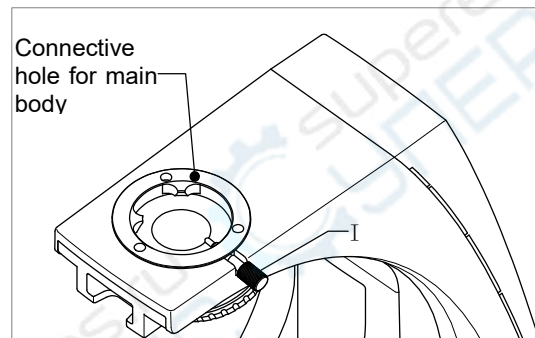

Fig. 3-4

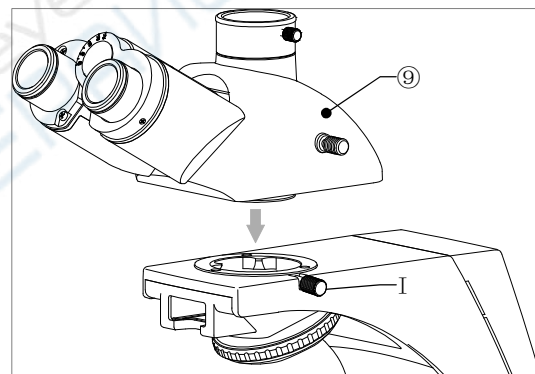

Fig. 3-5

3.2.2 Installation of eyepiece

Take out the eyepiece dust cover, then get the eyepiece from the packing bag (Fig. 3-6), and insert it into the tubes. (Fig. 3-7)

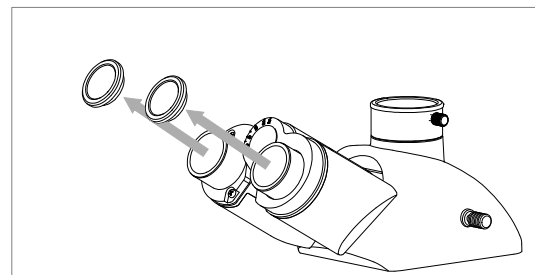

Fig.3-6

★ Please be careful not to touch the eyepiece lens for avoid unnecessary pollution, affect observation image.

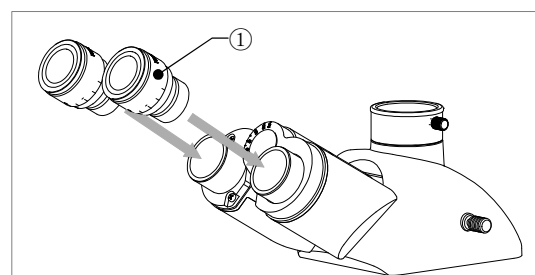
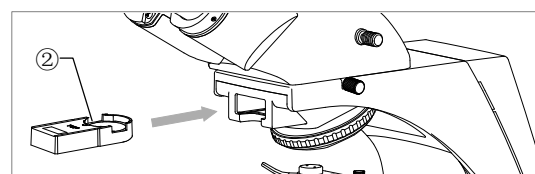

Fig.3-7

3.2.3 Installation of Accessory Box



Accessory box ③ can be inserted with analyzer and Gout detecting wavelength plate, etc. Putting in accessory box in direction(Fig. 3-8) until in good location.

3.2.4 Installation of Objective

Take out the objective ③ from the packing box, and screw them into the holes of nosepiece (C) orderly and tightly from low magnification power. Installing direction must in clockwise, the objective power from low to high in turn, just for good operation.

Fig.3-9

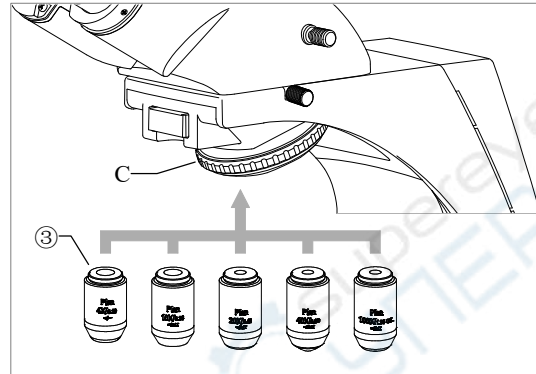

3.2.5 Installation of Condenser

(Fig.3-10) Rotating coarse focusing knob (V, O), rising Integrated stage ⑤ to the highest position. Turning the Adjusting knob for condenser (Q) to adjust the condenser holder ⑩ to the lowest position.

Fig.3-10

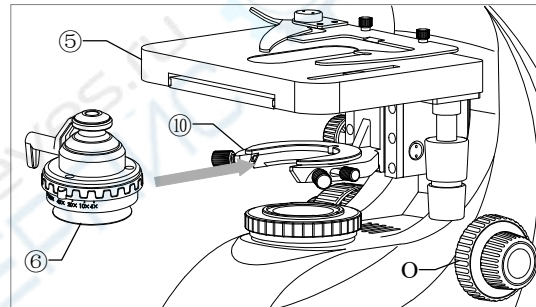

(Fig. 3-11) Loosening screw for condenser (J) (not unscrew completely), inserting condenser ⑥ to the holder and tighten up (J). Rotate adjusting knob for condenser (Q) to the highest position.

Fig.3-11

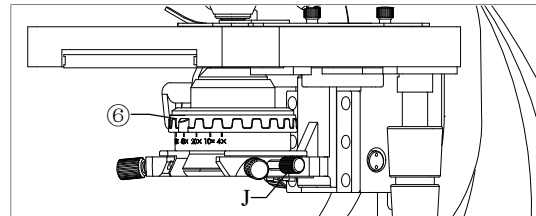

3.3 Carry

Microscope is a precision instrument, careful in carry. Turn power (S) off and turn to close (O), pull out power line. Lock the eyepiece tube and condenser etc, no slice left on stage. Don't move nosepiece, focusing knob, mechanical stage and eyepiece tube etc, don't make the eyepiece off. Avoid stumble into the chair, violent shocks and collision can cause damage.

★ Attentions in carry (Fig. 3-12)

Fig.3-12

With one hand turning back the microscope slightly by holding body handle (P), the another hand holding the microscope's front side.



4. Operation and Use

4.1 Operation process instruction

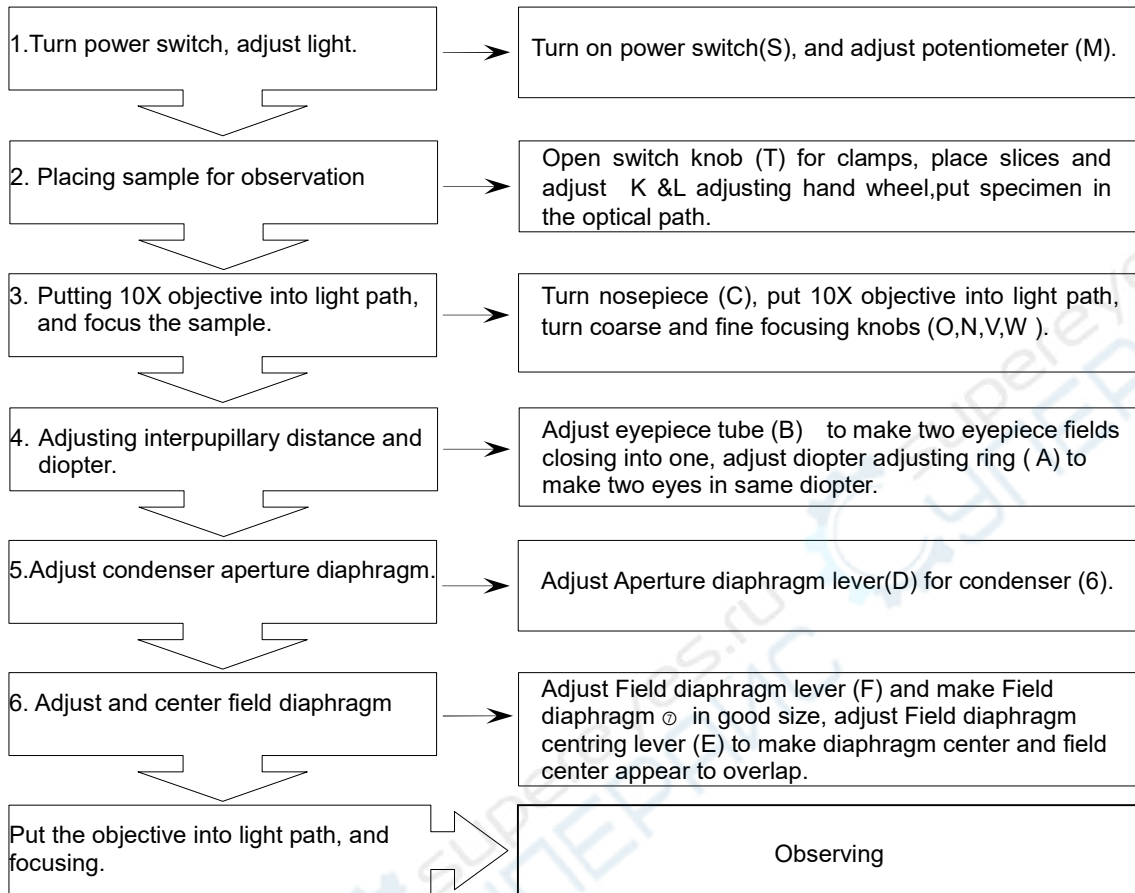

Problems in use:

- ▲ Cover slip: using cover slip of thickness 0.17mm can get ideal working environment for objective and reach design performance for best image.
- ▲ Slide glass: normal thickness 1.2mm (0.9~1.4mm).
- ▲ Interpupillary distance: It is different from person to person, so must readjustment each time.
- ▲ Avoid reverse rotating left and right coarse & fine focusing knob together, otherwise it will damage focusing unit.
- ▲ Don't switch objective directly when changing objective, should rotate the tooth ripple on nosepiece to put objective in optical path.
- ▲ Phenomena of automatic mechanical stage moving downward may occur after long-term use. Tension adjustment ring **R** can adjust firmness and comfortable sensation of the coarse and fine focusing knob, prevent moving downward. Clockwise rotation is relax, the reverse is fasten.

4.2 Methods for bright field observation

Step 1. Illumination -- Power on

(Fig.4-1) Supply voltage must be consistent with the rated input voltage, plug power line in power input socket ⑬.

Fig.4-1

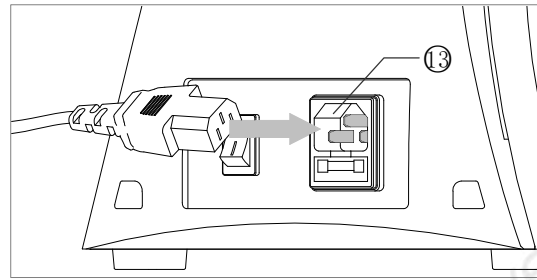

(Fig.4-2) Turn on power switch (S) and change to position (I). Rotate Brightness adjusting knob (M) for eyepiece field brightness.

Fig.4-2

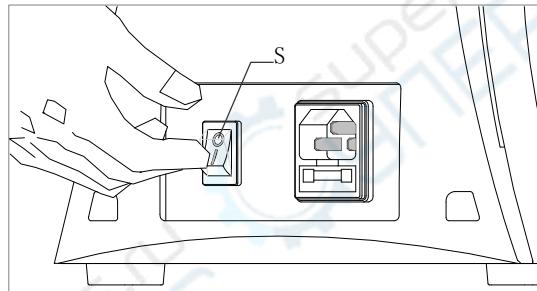

Step 2. Placing Sample (Fig. 4-3)

Rotate coarse focusing knob (V,O), lowering Stage ⑤ to suitable position, changing to 4X objective.

Loosening Clamps holder ④ and placing cover glass upside on the stage. (Carefully notice clamps holder, in case of damage for slice.)

Turning horizontal adjusting hand wheel (L) and vertical adjusting hand wheel (K), moving sample in the middle of optical path.

Fig.4-3

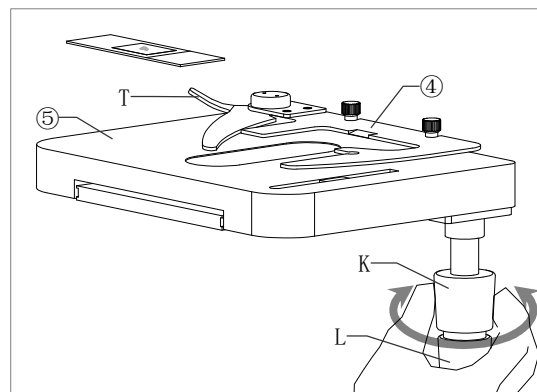

Step3. Focusing with 10X objective

10X objective with large field of view, long depth of view, suitable power can easy to find image plane and wouldn't miss sample message.(If firstly use ,can with 4X objective).

Fig.4-4

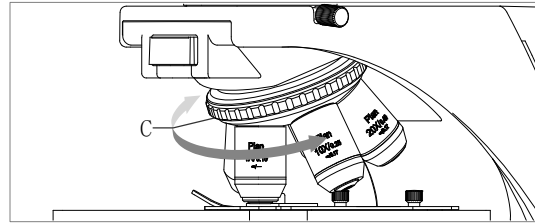

Putting 10X objective in the optical path by rotating condenser C (Fig. 4-4) , observing in right eyepiece , adjusting coarse focusing knob(O,V) (Fig. 4-5) to get outline image, then slowly rotating fine focusing knob (N or W) until getting more clearer image.

Fig.4-5

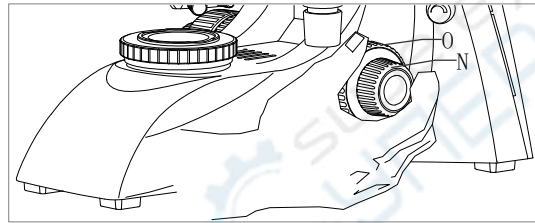

Step 4. Adjustment of interpupillary distance and diopter

(Fig. 4-6) Adjusting Interpupillary Distance adjustment

Holding the left & right eyepiece tubes (B) to rotate slowly until the binocular field are in superposition entirely.

Fig.4-6

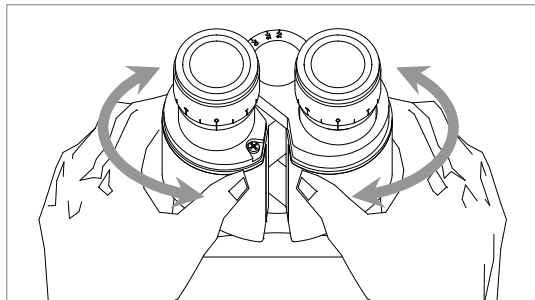

(Fig. 4-7) Adjusting Diopter

As focusing for binocular, user should observe with right eyepiece(scale of dioper adjusting ring A is zero 0) and make the right eyepiece clear by focusing adjustment, then observe the left eyepiece, at the same time, adjust the diopter ring (A) of the left eyepiece tube to make the image of left eyepiece clear as same as the right eyepiece.

Fig.4-7

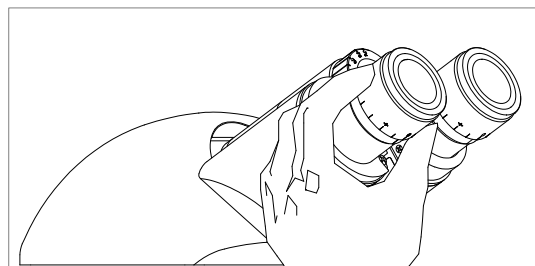

Step 5. Adjustment of Condenser Aperture Diaphragm

(Fig.4-8) Adjusting the distance between Condenser ⑥ and sample by rotating lifting knob(Q),changing illumination uniformity level for best brightness.

Fig.4-8

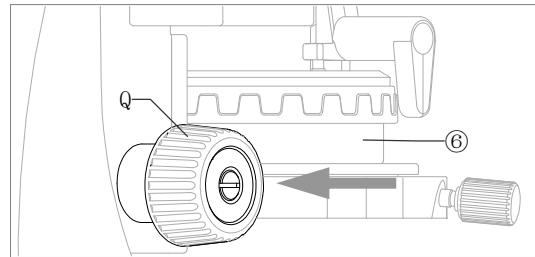

(Fig.4-9) Adjusting aperture diaphragm size by using aperture diaphragm lever (D) to change sample contrast.

If aperture diaphragm shrink ,brightness and resolution will lower, contrast and depth of field will increase, otherwise opening aperture diaphragm will get

Fig.4-9

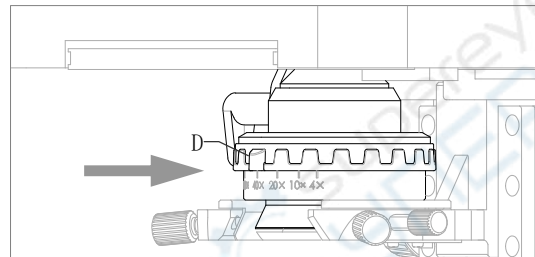

opposite effect.

Numerical aperture depend on illuminating system aperture diaphragm, but objective aperture diaphragm match with illuminating system aperture diaphragm, can provide perfect image resolution and contrast and field of focus will be increased.

Turning Aperture diaphragm lever (D) to the corresponding location in condenser, according to the image to make adjustment. (Fig.4-9)

(Fig.4-10) Compared with Abbe condenser, using swing-out condenser can make objective aperture diaphragm match with illuminating system aperture diaphragm. Upper condenser must be moved out of light path in 4X or 10X objective, if in high power objective, should adjust upper condenser in light path.

Fig.4-10

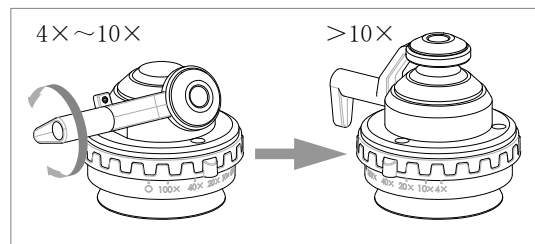

(Fig.4-11) Sample contrast is generally low, so condenser aperture diaphragm must be set from 70% to 80% of numerical aperture, also can observe in eyepiece tube and adjust the microscope without eyepiece.

(If Aperture Diaphragm size is too small, will get double image) .

Fig.4-11

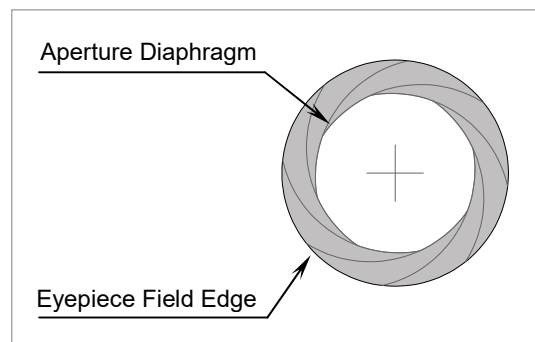

Step 6. Adjustment of field diaphragm and centering

Field diaphragm is used to limit the sample's range in field. If field diaphragm off center, the sample is also off center, especially when field diaphragm closed.

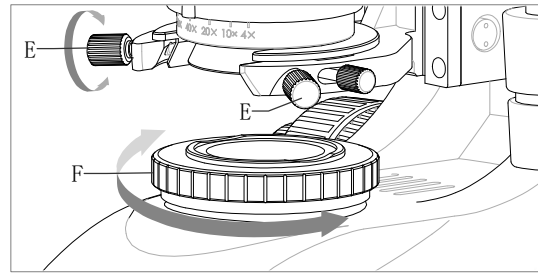

Fig.4-12

- Field diaphragm image centering adjustment
 - 1) Turning 10× objective in the light path , anticlockwise rotate field diaphragm lever **F** to close it. (Fig.4-12)
 - 2) Rotating upper condenser in light path(Fig. 4-10) ,rotating the adjusting knob for condenser **Q** to adjust condenser's height, can get clear field diaphragm image by eyepiece observation. (Fig.4-8)
 - 3) Rotating field diaphragm centring lever **E** (Fig.4-12) until image is moved in field centre. (Fig.4-13, Fig.4-14)
 - 4) Moving 20× or 40× objective in the light path, rotating Field diaphragm centring lever(**F**) to make diaphragm image more bigger than field.(Fig.4-15) If image not in centre, make centering adjustment again.

Fig.4-13

Fig.4-14

Fig.4-15

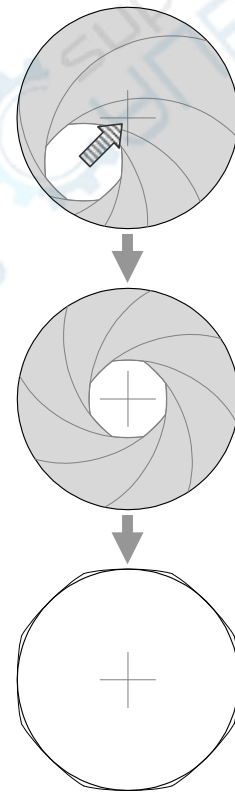

4.3. Use of Immersion Objective

Observed with immersion liquid between 100X objective front part and specimen can fully exert the largest effects for objective. 100X Oil immersion objective (S, Oil) or water immersion objective (S, W) can be chosen. Oil immersion objective with non-resin compound immersion oil, water immersion objective with distilled water. No bubble an impurity, or else effect image, corrode objective lens.

Fig.4-16

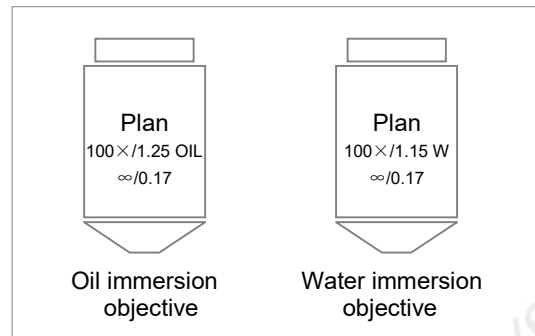

First, focusing with 40X objective for clear image and moving out of the optical path, then dropping a drop of immersion oil or distilled water (Fig.4-17), moving 100X objective in the optical path.

At this time, condenser should be gently rotated back and forth several times, making specimens of relative movement to the objective, to eliminate air bubbles in the oil, avoid bubble influence for image.

Fig.4-17

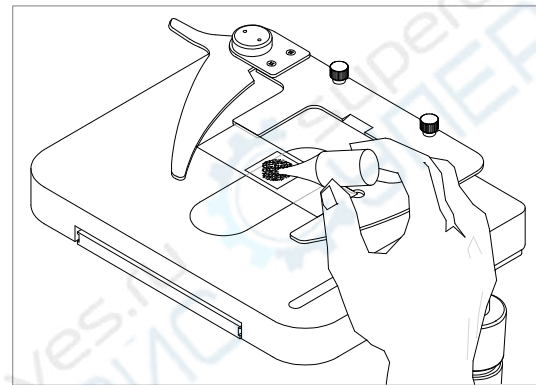

- ▲ Immediately after observing with absorbent cotton, lens paper, gauze or soft cloth dips in with industrial ethyl alcohol (proportion 1:4) to wipe the oil on instrument and slices.
- ▲ Although immersion oil is non-toxic, please thoroughly flush with soap and water if touching skin, such as thoroughly flush eyes with water for fifteen minutes, if the eye and skin appearance changes or pain, please immediately go to the hospital.

4.4. Matters need attention after use

4.4.1 After use, shut off the power (switch to "o" side, Fig.4-2), unplug the power socket.

(Fig. 4-1) If immersed in oil, should wipe clean the objective and slice. Finally the instrument should be covered with dust cover.

4.4.2 If instrument out of use for a long time, should pull the eyepiece, objective out from the body, and add dry containers (such as moisture proof cylinder), desiccant and placed. At the same time, the body should cover the corresponding dust cover, then dust-proof covers will host closely covered.

5. Installation and use of accessory

5.1 Filter

With matching filter as required, putting the filter in holder which on field diaphragm. (Fig. 5-1)

Fig.5-1

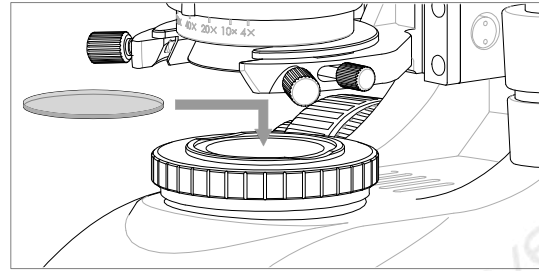

5.2 Polarizing unit

The polarizer unit is composed of analyzer and polarizer, can be used for identification of isotropic and anisotropic material nature.

5.2.1 Installation of polarizer

Putting polarizer on the field diaphragm ⑦, just hitching the filer holder's outer ring. (Fig. 5-2)

Fig.5-2

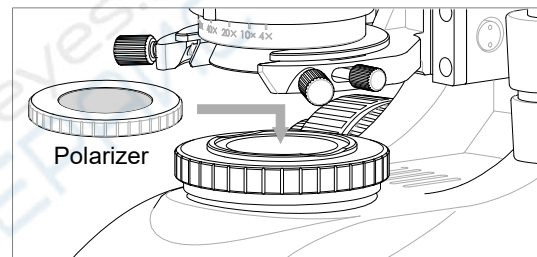

Take out the accessory module box② from the stand and put in analyzer (Fig. 5-3), the putting back accessory box following Step 3. (Fig 3-8)

Fig.5-3

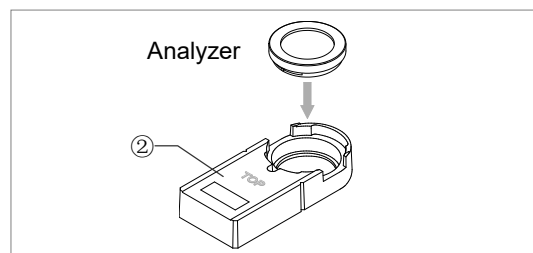

5.2.2 Use of polarizing unit

Refer to bright field operation to adjust microscope, adjusting Aperture diaphragm lever(D) to the maximum position. Making the sample out of the eyepiece field, rotating polarizer 360° will make the field changing from light to dark until the light is dark.

Placing the sample in the field of view and making orthogonal polarization qualitative observation.

5.3 Dark Field Unit

Observation with dark field unit can find some microscopic object points, less than limit of resolution which can't find in field observation. It can present the bright outline in dark background, especially suitable for observe those field point with low contrast and high refraction.

Optional accessory :

Dry condenser (Fig. 5-4)

Oil condenser (Fig. 5-5)

Dark field condenser installation can refer to Step. 5 for Swing-out condenser. (Fig. 5-6)

First, adjust the microscope with bright field steps, and then change the swing-out condenser with dark field condenser, rotating lifting knob **Q** to change the height and adjusting center with field diaphragm centring Lever **E** for best result, can begin observation.

Immersion dark field condenser must with 100X immersion objective for suitable numerical aperture to make observation.

When using immersion dark field condenser, must remove the sample, adding a few drops of oil in the center lens of the dark field condenser (Fig.5-7).

Placing the sample section in the stage clamps (Fig.4-3), fine focusing condenser with condenser lifting knob **Q**, rotating horizontal adjusting hand wheel (**L**) and vertical adjusting hand wheel (**K**), making sample section and condenser to relative move, eliminating bubble.

- ▲ Dry dark field condenser can't use with 100X oil Objective.
- ▲ Please clean the condenser after using immersion oil.

Fig.5-4

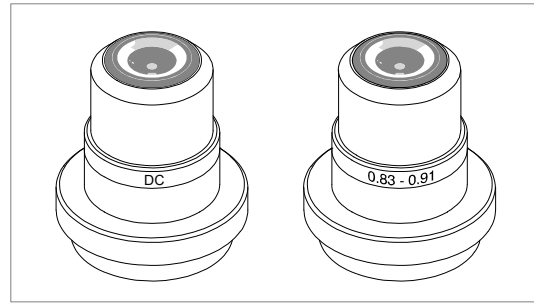

Fig.5-5

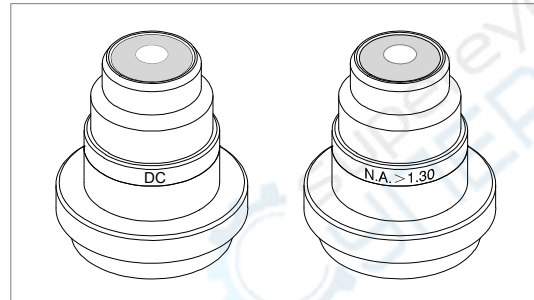

Fig.5-6

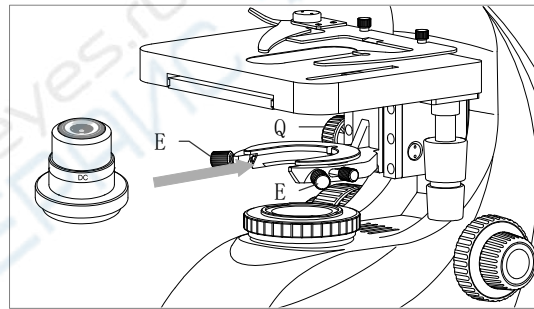
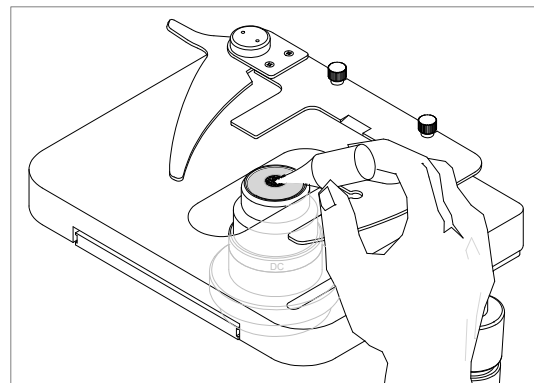

Fig.5-7



5.4 Phase Contrast Unit

With phase contrast unit can observe sample which have little difference in refractive index and thickness of surrounding media or colorless and transparent sample without staining.

Including independent phase contrast unit and turret phase contrast unit. Each unit have independent phase contrast condenser or turret phase contrast condenser 10X,20X,40X,100X phase contrast objective,centring eyepiece, filter.

5.4.1 Independent Phase Contrast Condenser

According to service condition , choose optional slider from four standard accessory, orresponding matching phase contrast objective, also use hree- holes phase contrast slider to install two power slider.(Fig.5-8)

Fig.5-8

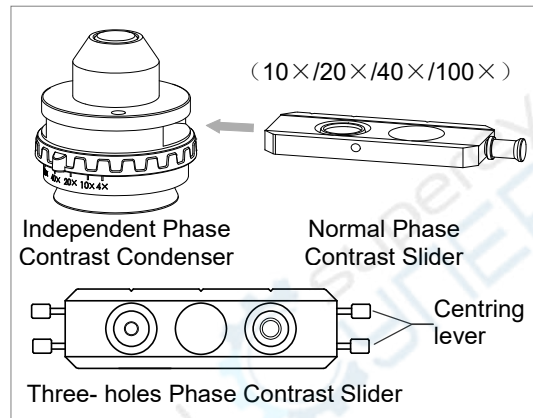

5.4.2 Turret Phase Contrast Condenser

Phase contrast slider installed in the condenser turret, change slider by rotating turret,with relevant phase contrast objective. Centring lever can adjust phase contrast slider position. (Fig.5-9)

Fig.5-9

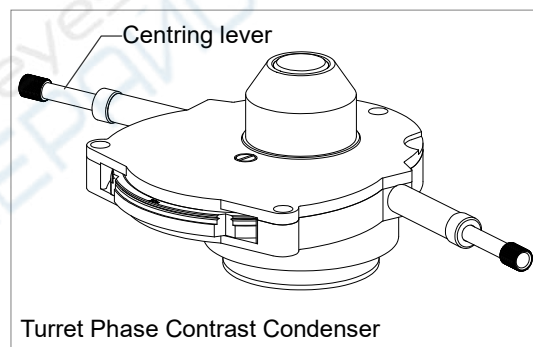

5.4.3. Phase Contrast Objectives

Only for phase contrast observation, with mark PH in green letters . (Fig.5-10)

Fig.5-10

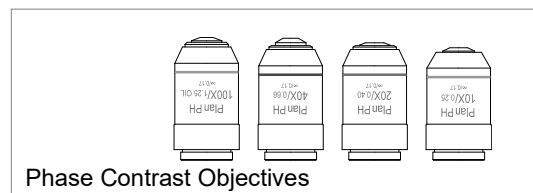

5.4.4. Centring Eyepiece

With three-holes phase contrast unit or turret condenser to adjust the phase contrast slider, can use centring eyepiece for best observation effect. (Fig.5-11)

Fig.5-11

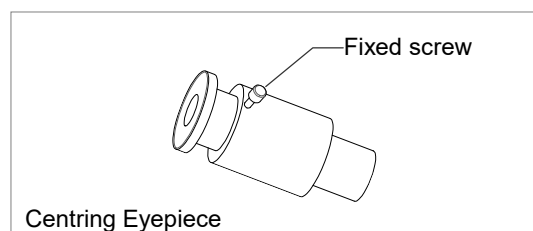

5.4.5. Installation

Consult Step 4 to install Phase Contrast Objective and Step 5 to install independent condenser or turret phase contrast condenser. Please note condenser in forward direction .(Fig . 5-12)

When installing independent condenser, please turn mark **TOP** upwards.

Fig.5-12

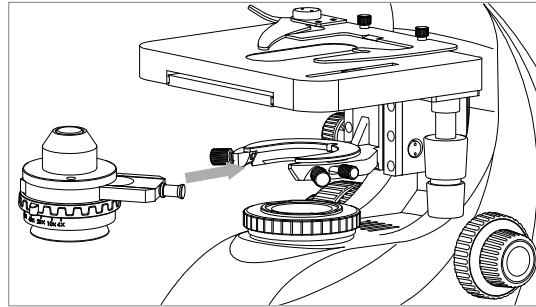

5.4.6. Independent Phase Contrast Unit

According to objective magnification power, equipped with 10X,20X,40X,100X phase contrast slider ,has relevant mark.

Normal phase contrast slider has two holes, PH hole and bright field through-hole, convenient transform between PH observation and bright observation. Three-holes phase contrast slider has two PH holes and one bright through-hole ,centring lever.(Fig.5-8)

Reference to bright observation method to adjust the microscope, adjust aperture diaphragm to the maximum PH position. (Fig.5-13)

Fig.5-13

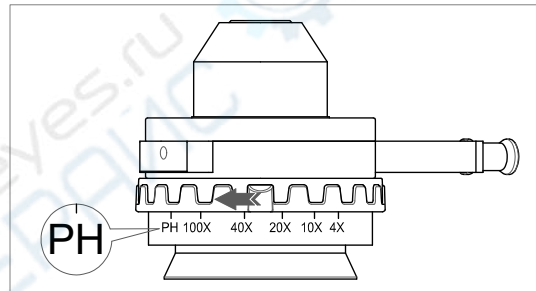

Put the filter on the ielddiaphragm .(Fig.5-1)
Moving the Phase contrast objective in the light path. Inserting relevant phase contrast slider into the condenser right slot, after phase contrast slider at right location(Fig.5-8)can begin phase contrast observation.

5.4.7. Turret Phase Contrast Unit

Adjusting turret phase contrast condenser to mark " O",referring to bright observation method to adjust instrument.

Fig.5-14

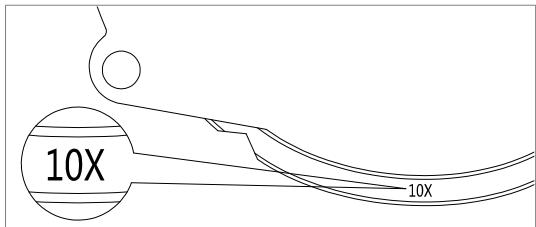

Putting phase contrast objective in the light path ,rotating phase contrast condenser turnplate, relevant multiplying power scale in front side (Fig.5-14) , when feeling phase contrast slider in right location, can begin phase contrast observation.

5.4.8. Centring Adjustment For Phase Contrast Slider

- ▲ Independent normal phase contrast slider don't need centring because of adjustment in factory.
- ▲ Independent three-holes phase contrast slider and turret phase contrast condenser slider need centring adjustment.

Use 10X PH Objective as example:

Putting 10X PH objective in the light path, adjusting slider relevant hole to position or moving turnplate to mark "10X" (Fig.5-13) , adjust aperture diaphragm to the maximum.

Replacing one eyepiece with centring eyepiece, loosening the fixed screw, pulling the eyepiece top and observe the field, phase contrast slider clear imaging, then locking the screw. (Fig. 5-15)

Fig.5-15

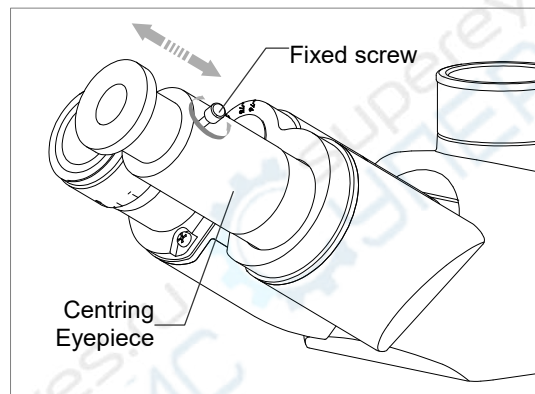

Rotating two centring handle (Fig.5-8, Fig.5-9 — turret phase contrast condenser's centring handle must be pushed adjusting into location) , turn and adjust the center of spot to overlap the bright ring and dark ring .(Fig.5-16)

Replace the centring eyepiece by eyepiece to observe.

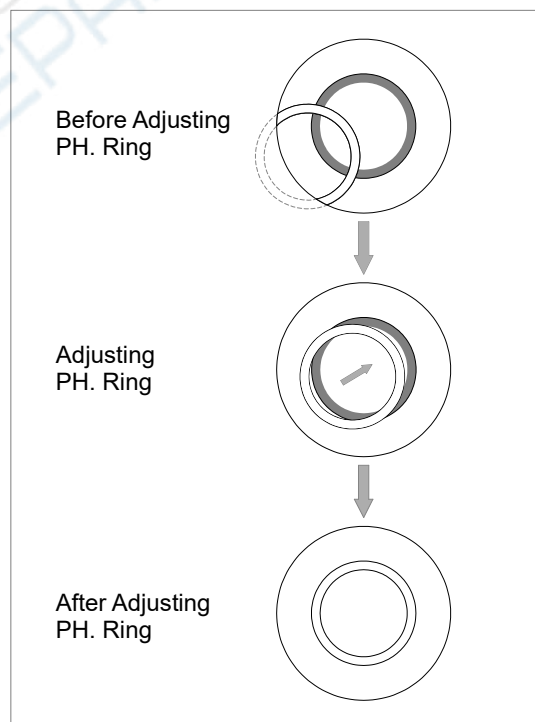

Fig.5-16

6. Installation and use for digital camera and photographic device

6.1 Installation (Fig.6)

6.1.1 If use digital device, trinocular tube's close nipple must be connected with standard C-mount, then connect digital camera with C-mount, so eyepiece picture can synchronize with display device image and locking screw again.

6.1.2 If use digital SLR camera or photographic equipment, should connect with relevant camera adaptor, then joint it with C-mount again. Finally, connect the photographic equipment with trinocular tube.

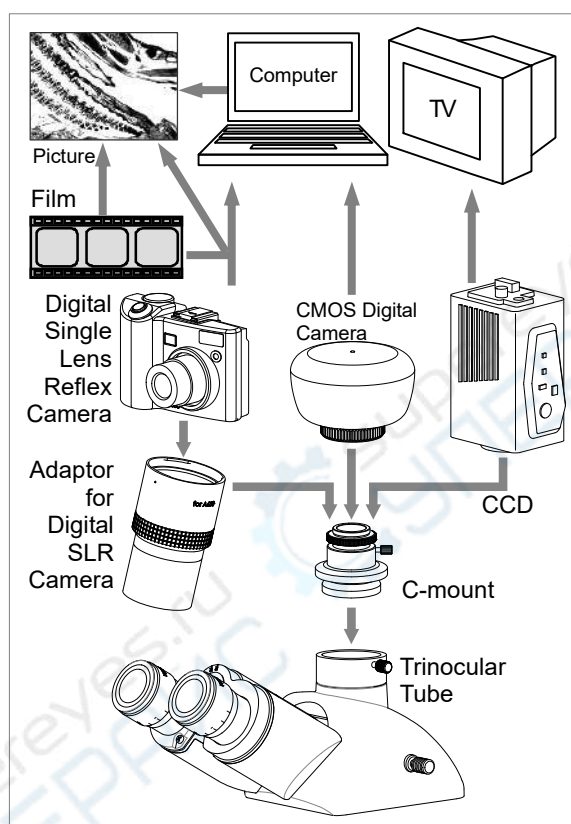

Fig.6

6.2 Use

After the connection, open image display device (computer or camera) and use software to collect image, clear or basic clear image should also be get in the screen (if isn't satisfied only slightly rotating N&W fine focusing hand wheel), until get satisfactory imaging results.

- ▲ Use eyepiece tube lever to make photographic operation, no need to change optical path with trinocular lever.
- ▲ Equipped adaptor can make eyepiece observation synchronizing image with photographic device. If can't get satisfactory image, please adjust photographic device's focusing unit.
- ▲ About connection and operation for video camera, monitor, please see relevant manual.

7. Installment and use for fluorescence device

Fluorescence microscope has wide applications in basic theory research and clinical diagnosis about medicine, biology, as well as analysis and test in industry, agriculture, stockbreeding, criminal investigation, legal medical appraise, environmental protection etc.

Some objects can emit a ray which wavelength is longer than that of the excitation light when irradiated. This ray is called fluorescence, and observers can study the objectives through fluorescence microscope using the phenomenon.

The light emitted from the lamp is converted to the excitation light (e.g blue light) with specified wavelength by going through the excitation filter, then passes through dichroic prism and objectives (the objective plays role of condenser) to irradiate vertically the object. The object is excited and emits fluorescence with specified wavelength (e.g. green and yellow) and make image passing through objectives, dichroic prism and eyepieces. The light (including excitation light) without fluorescence wavelength is reflected or absorbed by dichroic prism and barrier filter, and can not reach the view system.

Fig.7-1

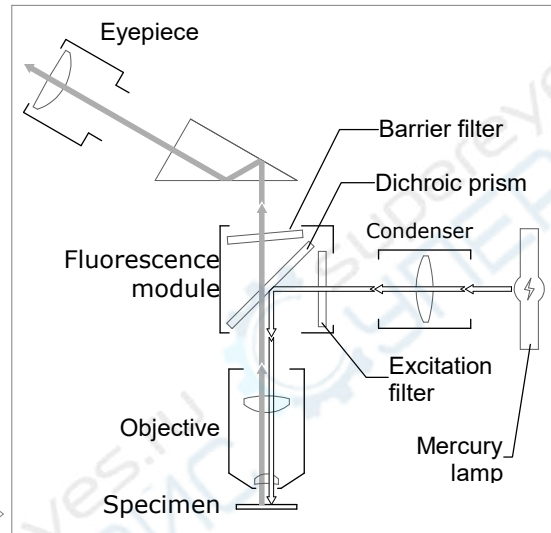

Therefore, what can be seen in the view field is the bright fluorescence image against the dark background. (Fig.7-1)

The device consisting of reflecting fluorescence illuminator, mercury lamp power box and fluorescence objectives are combined with mainbody to make up fluorescence microscope. The device is designed and manufactured with Epi-excitation principle and provided with 4 group excitation filters system of FL4: blue (B), green (G), violet (V) and ultraviolet (UV). Auramine is optional used for tuberculosis 455mm.

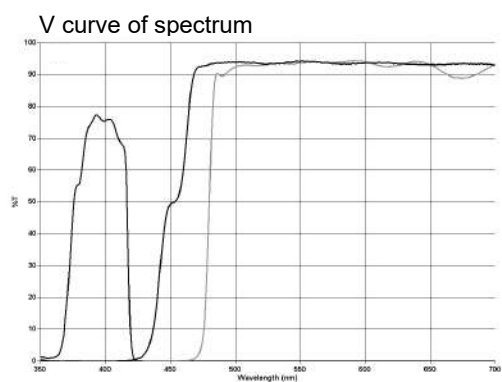
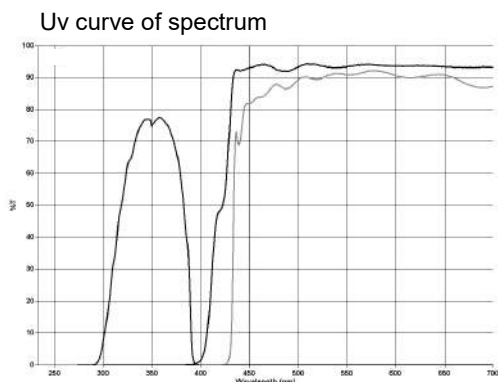
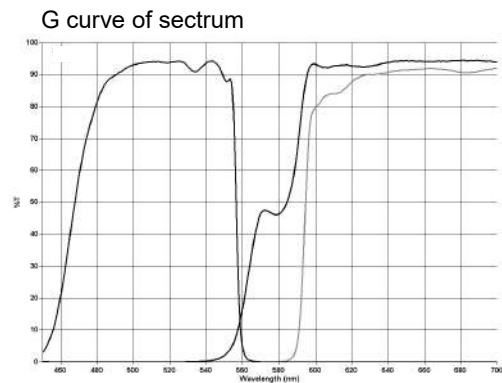
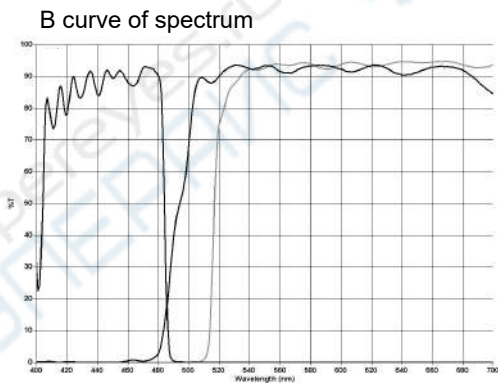

7.1 Parts Name

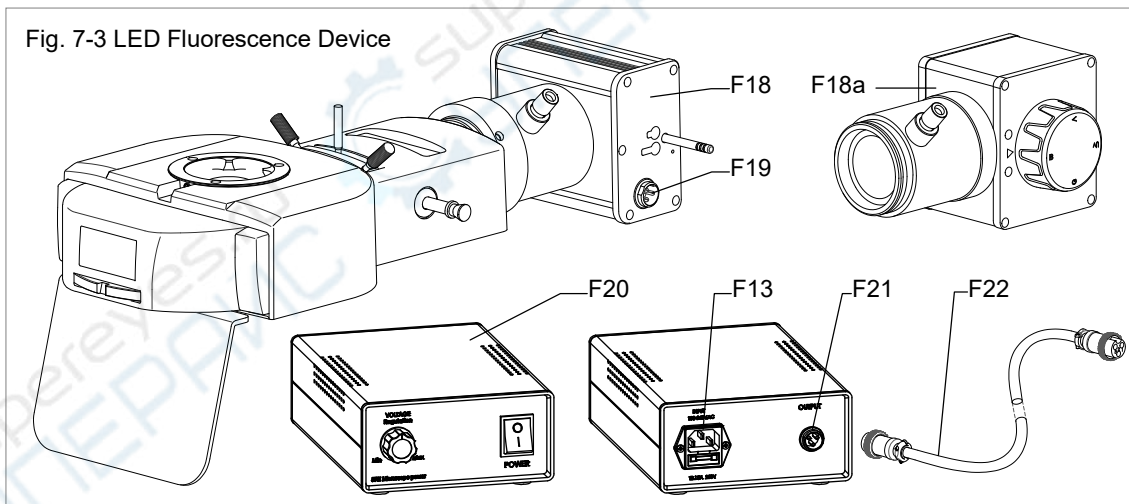
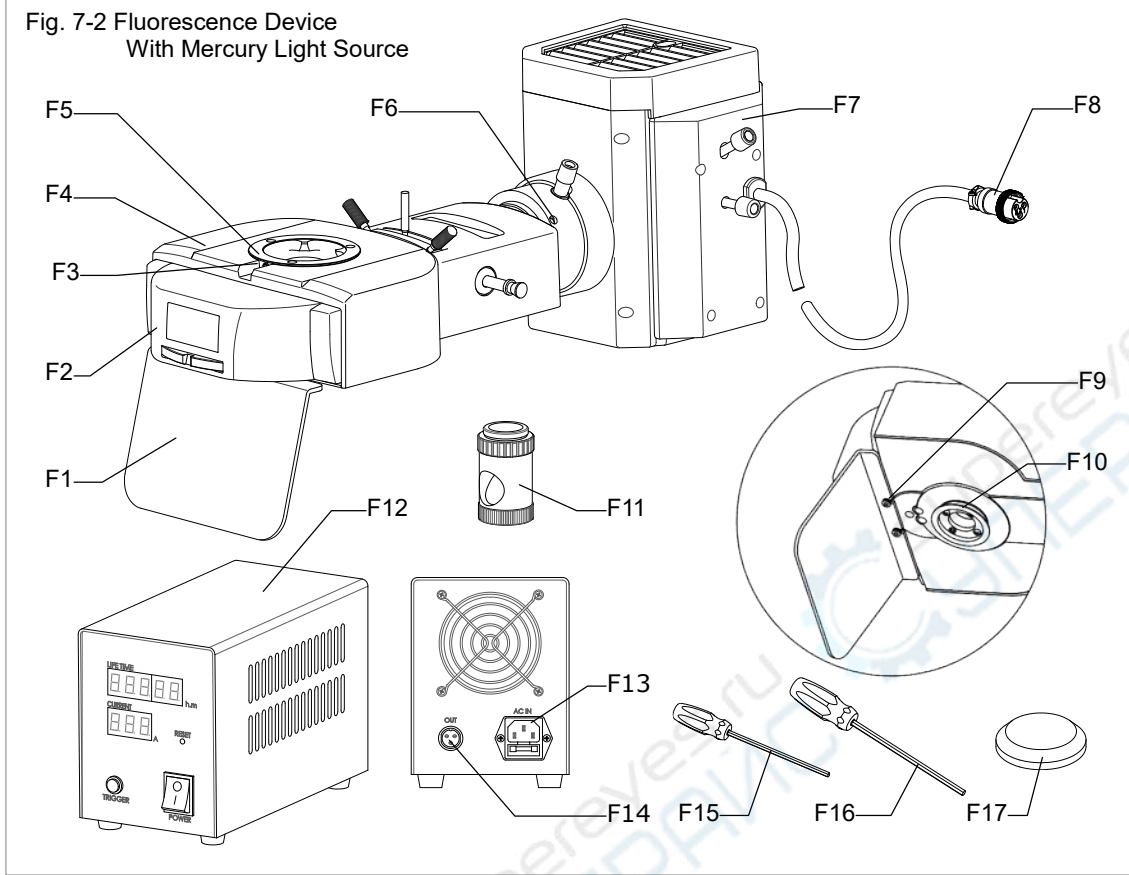

- | | | |
|--------------------------------------|---|-------------------------------------|
| F1. Protective plate | F9. Mounting screw for protective plate | F17. Condenser cover |
| F2. Front cover | F10. Main body connector | F18. 2 LED fluorescent illuminator |
| F3. Locking screw for observing tube | F11. Fluorescent centering device | F18a. 4 LED fluorescent illuminator |
| F4. Main body | F12. Mercury lamp power box | F19. Illuminator input socket |
| F5. Observing tube connector | F13. Power input socket | F20. LED power box |
| F6. Lamp box locking screw | F14. Output interface | F21. Output socket for power box |
| F7. Fluorescence mercury lamp box | F15. Hexagon wrench (2.5mm) | F22. Power connecting wire |
| F8. Power socket | F16. Hexagon wrench (3mm) | |

7.2 Installation (In mercury lamp)

Step 1.

- 7.2.1. Take out the component from the packaging box, remove the protective package and place the mainbody on the vacant working table.
- 7.2.2. Install the mainbody by following the Installation Steps .
- 7.2.3. Take out the fluorescent device , turn it over ,stick the Protective plate **F1** into Mounting screw **F9**, and tighten the screw with wrench (Fig.7-2).
- 7.2.4. Finally, keep fluorescent device in upright position, insert F10 Main body connector into Connective hole (Fig.3-4) , use Locking screw **I** to fasten.

Step 2.

- 7.2.5. Use F15 Hexagon wrench to loosening F6 Locking screw, connecting the lamp box front connector with fluorescent device's rear lens connector (Fig.7-4), adjust the lamp box and fasten F6 Locking screws .
- 7.2.6. Insert F8 Lamp box power plug into F14 Output interface, properly locking the screw.

Fig. 7-4

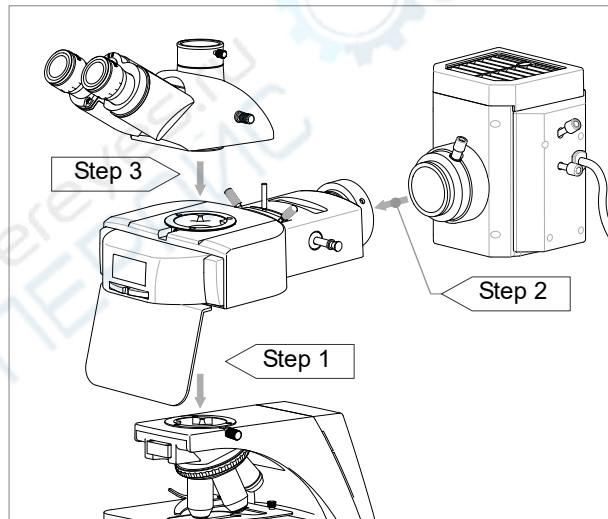

Step 3.

- 7.2.7. Loosen F3 Locking screw with F15 Hexagon wrench.
- 7.2.8. Reference installation Step 1, inserting connecting base into observing tube connector, with F15 Hexagon wrench to locking screw F3 for observing tube.
- 7.2.9. Insert external power source plug in F13 power socket.(Fig.4-1)

Installation finished. (Fig. 7-5)

- ▲ Switching on the power, Please carefully check whether power supply voltage is in conformity with input voltage.

Fig. 7-5

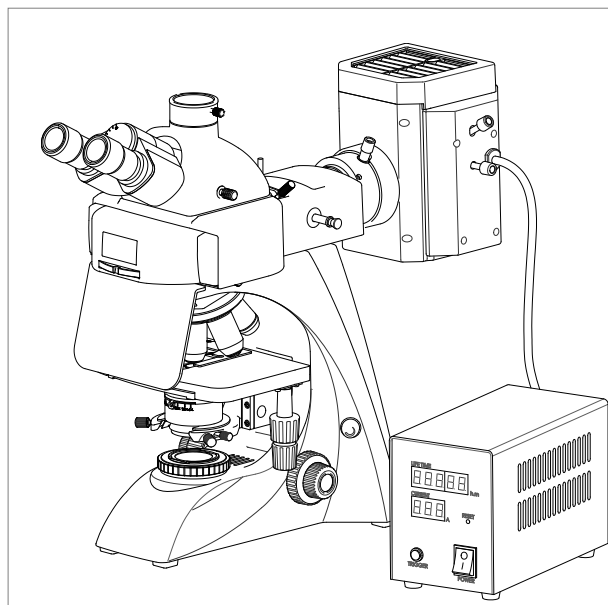

7.3 Fluorescence device Parts Name

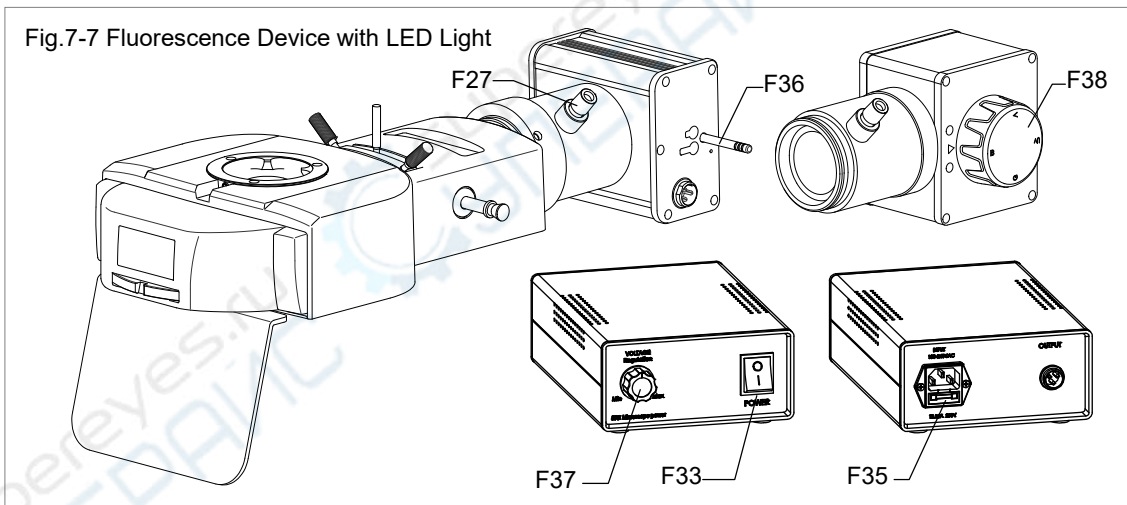
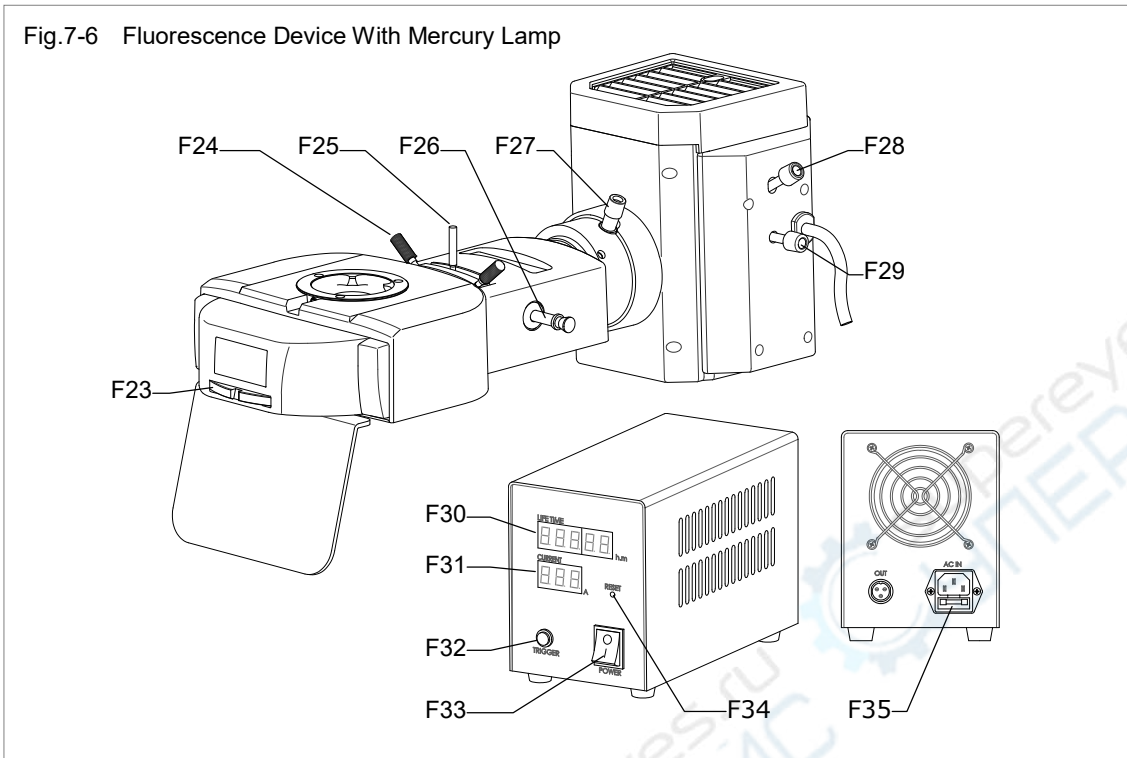

- F23. Fluorescence module switch driver
- F24. Field diaphragm centering handle
- F25. Field diaphragm adjusting lever
- F26. Light switch lever
- F27. Condenser adjusting lever
- F28. Light source vertical adjusting knob
- F29. Light source horizontal adjusting knob
- F30. Time display window

- F31. Electricity display window
- F32. Mercury start button
- F33. Power box switch
- F34. Reset button
- F35. Fuse holder
- F36. 2 LED light source switch lever
- F37. Brightness adjusting knob (optional)
- F38. 4 LED light source switch knob

7.4 Operation of fluorescence unit

Adjust the instrument with bright field methods and use the following steps :

- 7.4.1. Shut off the power switch **S** , turn on mercury power box switch F33,waiting 2 minutes for stable operation mode. Press F32 mercury start button (Fig.7-8) . (It will take 10 minutes to stable operation mode for maximum luminous efficiency.)

Fig.7-8

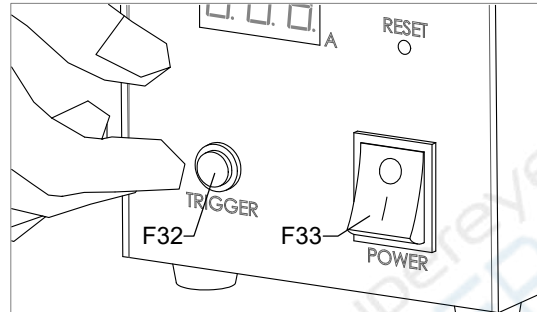

- 7.4.2. Putting 10×fluorescence objective in light path(Fig.4-4) and lowering condenser © to the lowest position (Fig.4-8) ,or swing out the Condenser Top Lens, cover with lid or remove the condenser © . (Fig.7-9)

Fig.7-9

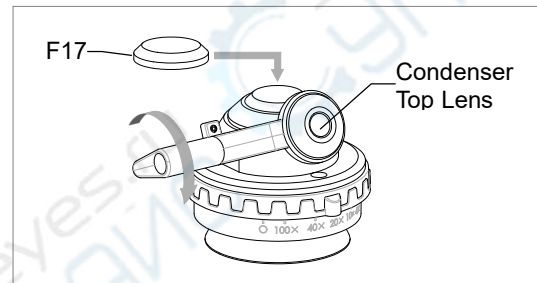

- 7.4.3. Placing fluorescence sample on stage © , fixed with clamps© , adjusting Vertical adjusting hand wheel and Horizontal adjusting hand wheel (K,L), to make the sample in light path.

- 7.4.4. According to the front label identifiers, pull the filter converting lever to the needed position. (Fig.7-10) .

To make light source match each other, when with LED fluorescent illuminator F18 ,must use LED light source switch lever.

Fig.7-10

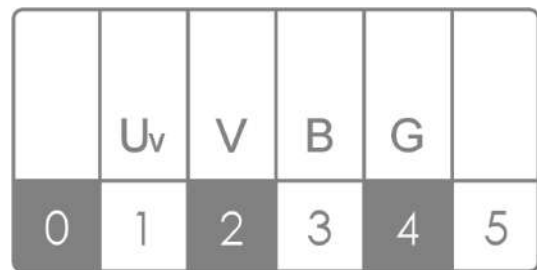

- 7.4.5. Adjusting field diaphragm lever F25 to the maximum open scale(if necessary , adjusting the field diaphragm centering handle F24 to diaphragm and field in the same centre. (Fig.7-11)

Fig.7-11

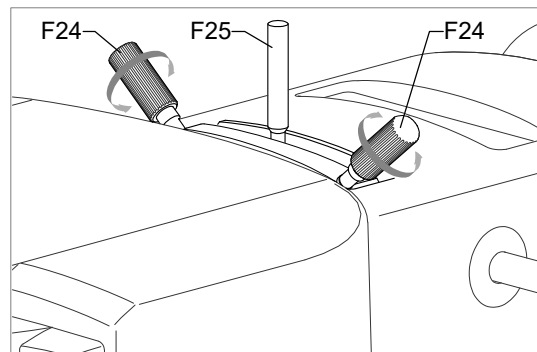

7.4.6. Adjusting coarse and fine focusing knobs (N,O,V,W) to get clear image.(Reference diagram 4-5) .

7.4.7. When field background luminance is uneven, can rotate condenser adjusting lever F27 to adjust. (Fig.7-12)

Fig. 7-12

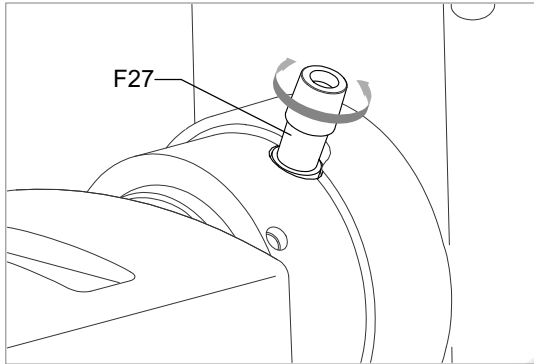

7.4.8. After get ideal imaging, can with the other objective to make observation

▲ Before perform epi-fluorescence observation, locate the specimen with the transmission light first.

▲ To prevent the fluorescence from attenuation quickly, block the excitation light with barrier when preparing for fluorescence observation or photography. Only when observing or photographing, irradiate the specimen with the excitation light. (Fig .7-13)

Fig. 7-13

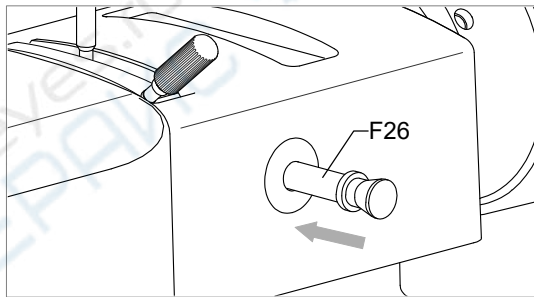

▲ If mercury lamp with strong light source, should in half light position of light shutter in case of sample cancellation. (Fig.7-13)

▲ Don't turn off the mercury lamp within the initial 15 minutes ,repeat switch will shorten working life. The user can cut off the light by pushing in light switch lever F26 if leaving for a short time, and the lamp once turned off should be lighted on again after 3 minutes.

▲ Fluorescence microphotograph requires a long exposure time, so the fluorescence digital photography device is the best choice.

7.5 Use of centering device

Mercury lamp source can't be seen with eyes directly , so lamp source center must be adjusted with centering device so as not to damage the eyes.

The visible brightness has been adjusted specially, The centering device can center directly the light source for convenient using. Its size is similar to the normal objective, and there is an observation window in the side of cover. (Fig .7-14)

Fig. 7-14

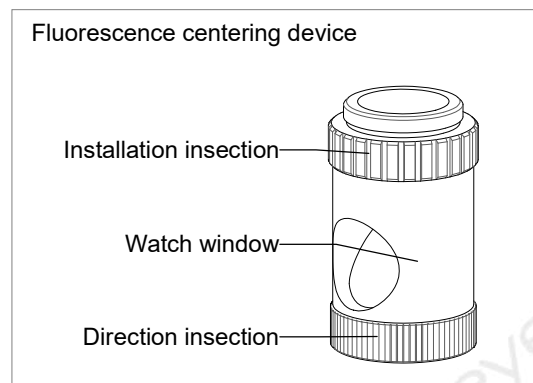

7.5.1 Holding the installation insection (Fig.7-14) and installing it on the nosepiece ,turning the cover of centering device to align the observation window .

7.5.2 Rotating the nosepiece ,making centering device to the working position. Then rotating direction insection , the watch window will in good direction for observation.(Fig. 7-14)

7.5.3 Rotating F23 fluorescence module switch driver, sliding to grade G, watching the light source's position through the window. The light source is just in the cross target line. (Fig. 7-15)

Fig. 7-15

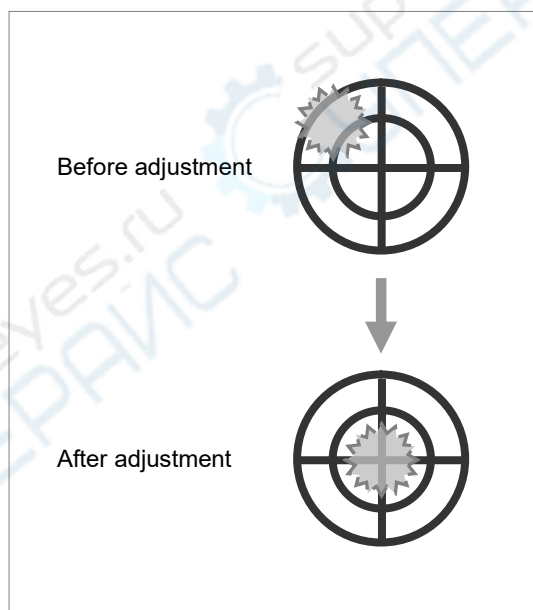

7.5.4 Rotating F27 condenser adjusting lever properly, and making the outline of the light source clear. (Fig. 7-12)

7.5.5 Rotating adjusting knob F28 and F29 which on the mercury lamphouse, light source will moving to the cross target line centre. (Fig.7-15)

7.5.6 When the cross target line centre in the watch window is aligned with the light source, the adjustment is finished.

▲ Please turn the fluorescence device to G , because the brightness of G is suitable for observation better to avoid to feel uncomfortable for high brightness.

▲ After adjustment with centering device, making fine adjustment for normal sample for best image effect.

8. Maintenance

8.1 Clean

8.1.1. Don't touch the lens with hand, Dust on lens should be cleaned by soft brush or absorbent cotton or cleaned by absorbent cotton, lens paper with the mixture of ethyl alcohol and ether. (proportion 1:4)

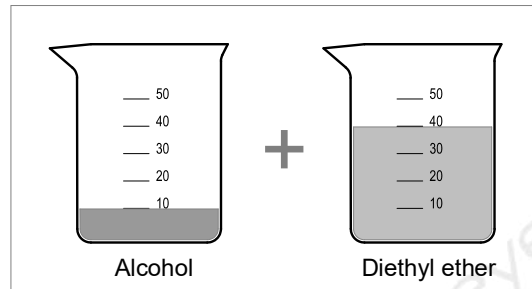

Fig. 8-1

8.1.2. Alcohol and diethyl ether all are burnt early, please take them away from fire. Be careful for turn on and off power.

8.1.3. Don't clean painted metal and galvanizing metal with organic solvent such as alcohol, diethyl ether or the mixture of the both. Silicon cloth or soft cleaning preparation can clean it.

8.1.4. Plastic surface should be cleaned by soft cloth with clear water.

8.2 Environment for use and storage

8.2.1. Microscope should be used and placed in a cool, dry, non-dust, non-shake and non-corrosive gases environment.

8.2.2. Microscope should be used in environment of indoor temperature 0°-40°C and maximum relative humidity 85%.

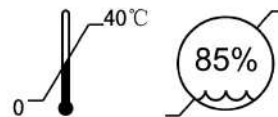

8.2.3. In high humidity area, dehumidifiers should be installed in case for mildew and frog.

8.2.4. Please pay attention to prevent microscope from violent shake and vibration in application and in carrying. Don't drag it on the surface of worktable to avoid damage to microscope and worktable.

8.3 Replacement of halogen bulbs

- ▲ With specified bulb (Halogen 6V/30W) .
- ▲ Please replace new bulb after completely cooling.
- ▲ Before installing the new bulb,check the bulb whether with plug bad contact. Bad contact will affect illumination.
- ▲ Completely insert bulb contactor into socket, if contactor is loose will lead to short circuit.



8.3.1. Turn off the power **S** (Change to “o”, Fig.4-2) ,pull out power line from socket

⑬.

8.3.2. Waiting about 15 to 30 minutes until the bulb is cooling down completely.

8.3.3. Putting down the main body backwards , keep stable. (For protection ,it's better to take down the eyepiece and observing tube, placing foam or book under the main body.(Fig.8-2)

Fig.8-2

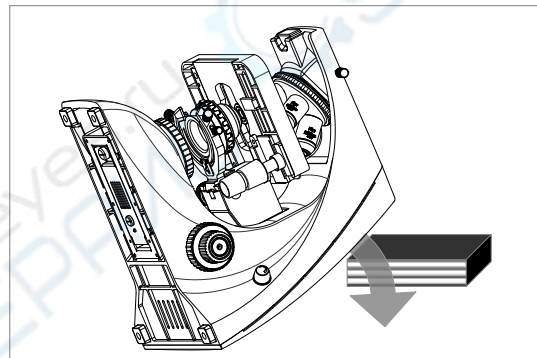

8.3.4. Unscrew the bottom cover knurled screw (Fig.8-3), pulling outward and open lamphouse. (Fig.8-4)

Fig.8-3

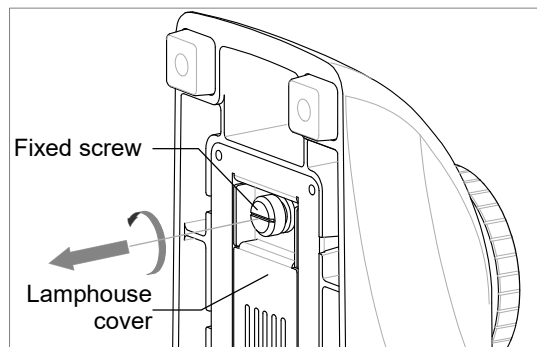
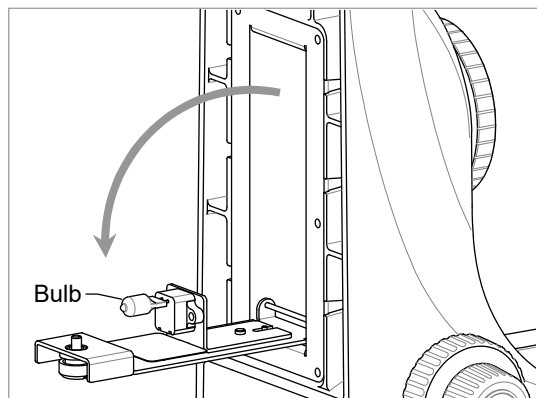

Fig.8-4



8.3.5. Please be sure that the bulb is cool, pull out the broken bulb.(In direction Fig.8-5)

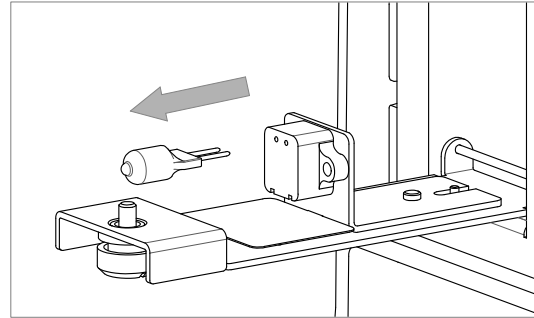

Fig.8-5

8.3.6. Hold a new bulb with silk cloth to avoid fingerprint and dust affect bulb brightness and service life(Fig.8-6), and insert the bulb holder.(Fig.8-5 in opposite direction)



Fig.8-6

8.3.7. Following the previous step to restore the main body in reverse order, clean the working desk.

8.4 Replacement of fluorescence mercury lamp

Ordinary working life from 100 to 200 hours, please replace it as the following steps when mercury lamp can't work .

- ▲ Danger! It is absolutely forbidden to take the lamp holder out of the lamp house while the mercury lamp lights on.
- ▲ The mercury lamp should not be replaced until it cools down completely.
- ▲ Notice the installation in positive and negative direction, adjust the uneven part of lamp to diverge the condenser.
- ▲ Clean the bulb with the gauze soaked with a few mixture of alcohol and ether (4:6) . Stains such as dust and fingerprint are not allowed on the bulb surface.



8.4.1 Turn off the power box switch F33, unplug the socket, waiting about 30 minutes until the light box, mercury lamp and relevant device are cooling.

8.4.2 With wrench F16 to insert the upper elliptical hole on the light box, unscrew the light box screw. (Fig. 8-7)

Fig. 8-7

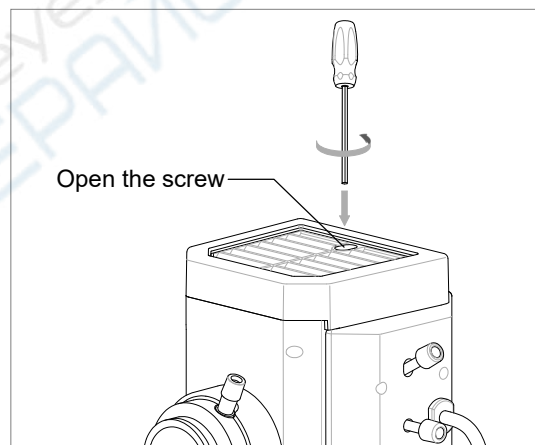

8.4.3 Holding the outer cover and bring the upper cover up. (Fig. 8-8)

Fig. 8-8

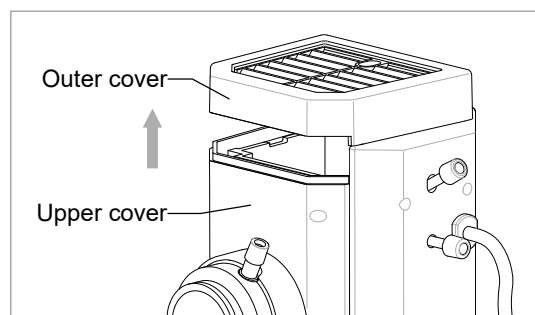

8.4.4 Reconfirm mercury lamp and relevant device are complete are cooling, loosening the two fixed screw. (Fig. 8-9)

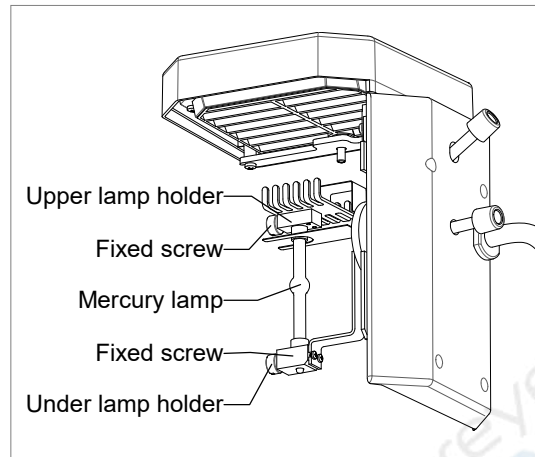

Fig. 8-9

8.4.5 Gently pushing upper lamp holder until mercury lamp electrode is loosen, removing the tube. (Fig. 8-10)

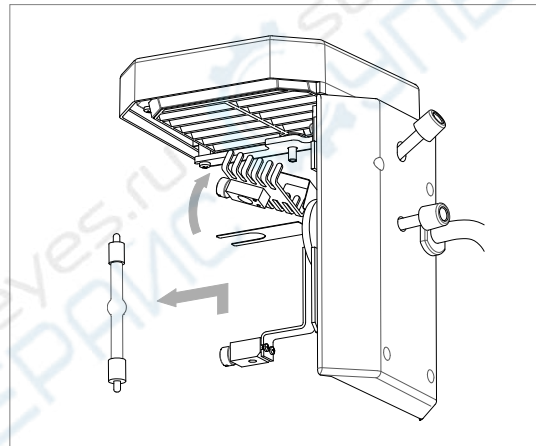

Fig.8-10

8.4.6 Hold new bulb with silk cloth to avoid fingerprint and dust which may affect bulb brightness and service life. According to electrode direction (mercury lamp electrode is corresponding to lamp holder's installing hole)to insert the mercury lamp into the under lamp holder.

8.4.7 Rotating mercury lamp to examine the lamp middle part,if uneven, changing the lamp to the reverse position of condenser, then tighten the two fixed screw of lamp holder.

8.4.8 Following the above steps to restore mercury lamp box.

8.4.9 If lighting effects unsatisfactory, please consult the steps for centring mercury lamp .

8.5 Replacement of fuse tube

Fuse tube should be installed in power input socket ⑬, fuse tube ⑭ or F35.(Fig.4-1, Fig.7-2, Fig.7-3)

8.5.1 Please turn off the power, unplug the power line. (Fig.4-1)

8.5.2 Remove the input socket fuse holder which behind the main body or power box (be careful not to be scratched by old fuse when with screwdriver). (Fig.8-11)

Fig.8-11

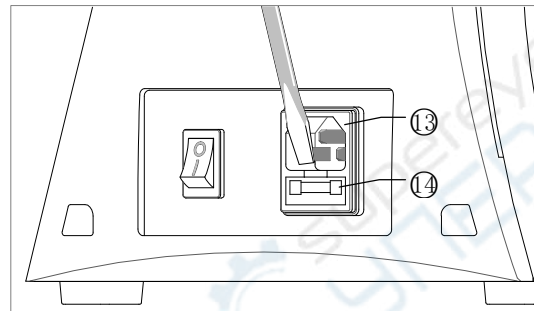

8.5.3 Take out old fuse tube. (Fig.8-12)

8.5.4 Replace with same size tube, insert into socket again.

Fig.8-12

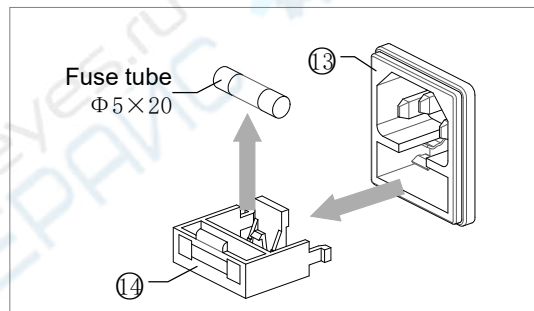

8.6 Storage

8.6.1 when not in use, must turn off power and placed in a cool, dry environment with dust-cover.

8.6.2 Eyepiece and objective should be placed in dry container with desiccant.

Appendix 1: Troubleshooting

In the period of using microscope, if there is any trouble occurs, please referring to the following sheet listed some common troubleshooting resolve them.







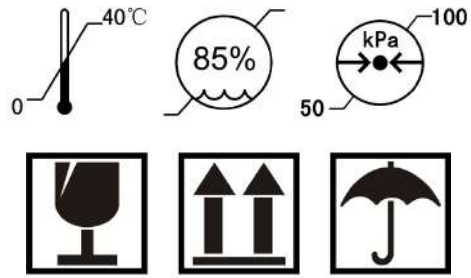



Trouble	Causation	Remedy
Switch on but bulb dark	No bulb	Install bulb
	Plug is unreliable	Check joint again
	Bulb is broken	Replace bulb
	Fuse is broken	Replace fuse
Bulb is flickering or brightness is unsteady.	Bulb is unstable	Insert again
	Bulb is broken	Replace bulb
Brightness of view field isn't enough or is uneven.	Bulb specification doesn't meet the requirement.	Replace bulb
	Bulb brightness is low.	Rotate potentiometer to adjusting brightness.
	Objective isn't in correct optical path.	Rotate the objective in correct position.
	The size of iris aperture is too Small.	Adjust the size of iris aperture.
	Lens (objective, eyepiece, condenser, light collector) has dust.	Clean it
	Position of Condenser is too low .	Adjust condenser properly.
Image isn't clear (contrast or definition isn't enough)	Cover glass of specimen doesn't meet the requirement.	Use required thickness cover glass (0.17mm).
	Cover glass of specimen isn't in up direction.	Place specimen correctly.
	Surface of objective lens Is dirty (especially it is easy for the front lens of 40× objective to dip in immersion oil).	Clean it
	Immersion oil isn't used for 100× objective (oil)	Use immersion oil
	Immersion oil doesn't meet the requirement.	Use immersion oil supplied by us.
	There is bubble in immersion oil.	Clear the bubble away
	Size of iris aperture isn't proper.	Adjust the size of iris aperture.
	Position of condenser is too low.	Readjust again
One side of image is dark or image is moving as focusing.	Objective isn't in correct optical path.	Make the objective in correct position..
	Specimen isn't placed correctly.	Place specimen levelly on stage and clip it with clamp.
Dirt and dust can be seen in Field of view.	Dirt or dust on bulb glass	Clean it
	Dirt or dust on specimen	
	Condenser's front lens has dust or dirt.	
	Lens (objective, eyepiece, condenser, light collector) has dust.	
Objective touching specimen as changing low power to high power	Cover glass of specimen doesn't meet the requirement.	Place specimen correctly.
	Cover glass is too thick.	Use required thickness cover glass (0.17mm).
Image observed by two eyes aren't in superposition entirely.	Interpupillary distance isn't adjusted correctly.	Adjust Interpupillary distance.
	Diopter isn't adjusted correctly	Adjust diopter
	Left and right eyepiece is different.	Replace same eyepieces.
It is easy for eyes to be tired during observing.	Interpupillary distance isn't adjusted correctly.	Adjust Interpupillary distance.
	Diopter isn't adjusted correctly.	Adjust diopter
	Brightness isn't enough	Adjust brightness

Appendix 3: Transport Environment

1. Temperature range in transit: 0~40°C.
2. Maximum relative humidity: 85%
3. Air pressure range: 50kPa~100kPa
4. Handle with care in case for damage.
5. Keep upward following sign .
6. Keep waterproof or infiltrate during transit.



Appendix 4: Identifier Meaning

	Main Switch “ ON ”
○	Main Switch “ OFF ”
	Fuse
	Attention
~	Alternating current
	Ground connection
	Can't touch the hot surface with hand, operation after power off and cooling down.
	Diaphragm directions, hollow circle is turn up, solid is turn down.
FD	Field Diaphragm
AD	Aperture Diaphragm
	Optical Shutter Pass 0
	Optical Shutter Pass 50%
	Optical Shutter Pass 100%
	Switch Directions , an enhanced thickness means heavy.
	Recycle Mark