

A6013L

DIGITAL C METER OPERATION MANUAL

1.FEATURES

- ✧ Easy and correct readout.
- ✧ High measuring accuracy.
- ✧ Measurements are possible even under a strong magnetic field.
- ✧ LSI-circuit provides high reliability and durability.
- ✧ Input overload protection is provided.
- ✧ LCD display for low power consumption and clear readout even in bright ambient light conditions.
- ✧ In-line pushbuttons allow one hand operation.
- ✧ Light-weight and compact construction for easy operation.
- ✧ Low battery condition is indicated on the LCD display.

2. Panel Layout

- ① LCD Display: 3½ digits, character 15mm high
- ② Back Light Button Switch: Press this button to switch on back light if the dark circumstance light makes the reading difficulty when measuring, the light will be automatically turned off in 5 seconds. Press again to switch it on again. If the battery is in weak power, the light will be dimmed.
- ③ Rotary Switch: use this switch to select ranges
- ④ “COM” Input Jack
- ⑤ “Ⓜ+” Input Jack
- ⑥ Data-hold Switch (HOLD)
- ⑦ Zero ADJ.

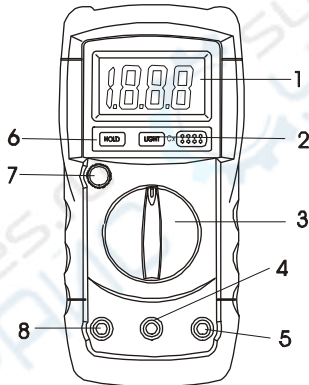

2.SPECIFICATIONS

2-1.GENERAL SPECIFICATIONS

Display :LCD (Liquid Crystal Display) Max Indication 1999.
 LCD Backlight and data hold.
 Measurement:C (Capacitance)
 Range :single 9 position, whole range value (from 0.1pF to 20000uF)
 Zero Adjustment :Manual (range:±20pF)
 Calibrate Adjustment :Have two internal adjustment. One is panel Zero adjustment.
 Over-input :Display shows “1”.
 Sampling Time :3/second
 Operating Temp :0°C to 40°C.
 Operating Humidity :80% MAX.R.H.
 Power Supply:Single, standard 9 volt battery. NEDA 1604IEC6F22
 Battery Life :Alkaline type approx.: 200 hours.

Zinc-Carbon type approx.: 100 hours
 Typical consumption current :3~4mA (200pF-200uF)
 Standard Accessories: Test alligator clips (red & black)...1 pair.
 Instruction manual.....1 pc.

2-2. ELECTRICAL SPECIFICATION

Accuracy is ±(percentage of reading + number of digit) at 23±5°C,<80%RH.

Range	Accuracy	Resolution	Test	Max
200pF	±(0.5%+1d)	0.1pF	820Hz	199.9pF
2nF		0.001nF		1.999nF
20nF		0.01nF		19.99nF
200nF		0.1nF	82Hz	199.9nF
2uF		0.001uF		1.999uF
20uF		0.01uF		19.99uF
200uF	±(2.0%+2d)	0.1uF	8.2Hz	199.9uF
2000uF		1uF		1999uF
20mF	±(4.0%+10d)	0.01mF		19.99mF

pF= Pico Farad($10^{-12}F$), nF= nan Farad($10^{-9}F$). uF= micro Farad($10^{-6}F$)
 Zero Error: ±20pF
 Excititive voltage: Max.2.8Vrms
 Overload Rating: Protection by a 0.2A/250V fuse.

3. CONSIDERATION OF MEASUREMENT

- (1) This C METER is intended for measuring the capacitance value of a capacitor. It is not intended for determining the "Q" factor for above reactive components. Misleading readings may be obtained if the measurement of capacitance of a resistor is attempted.
- (2) When measuring components within circuit that circuit must be switched off and de-energized before connecting the test leads.
- (3) Do not close (black & red) test leads.
- (4) Instruments used in dusty environments should be stripped and cleaned periodically.
- (5) Do not leave the instrument exposed to direct heat from the sun for long periods.
- (6) Before removing the battery and fuse compartment cover, ensure that the instrument is disconnected with any circuit and the power switch is in the off position.
- (7) For all measurements, should connect BLACK test lead into "-" terminal and RED test lead into "+" terminal.

4. CAPACITANCE(C) MEASURING PROCEDURE

- (1) Select the range switch for the maximum expected capacitance.
- (2) Check "0" indication: If test range is 200pF, 2nF, 20nF, should check "0" indication before test.
- (3) Observe polarity when connecting polarized capacitors.
- (4) Full discharge any capacitors.
- (5) Connect the alligator clips to the capacitors leads.
- (6) Read the display. The value is direct reading in the electrical unit (pF, nF, uF) indicated at the selected range switch. If display show "1", It indicate on Out-of-Range measurement. If the display indicates one or more leading zeros, shift to the next lower range scale to improve the resolution of the measurement.

NOTE:

- (a) If the capacitance value is unmarked, start from the 200pF range and keep increasing until the over-range indication goes off and a reading is obtained.
- (b) A shorted capacitor will read over-range on all ranges. A capacitance with low voltage leakage will read over range, or a much higher value than normal. An open capacitor will read zero on all ranges (possibly a few pF on 200pF range, due to stray capacitance of the

instrument).

- (c) Very low capacitance measurement should be performed by using extremely short leads in order to avoid introducing any stray inductance.
- (d) When using the optioned test leads, remember that the leads introduce a measurable capacitance to the measurement. As a first approximation, the test capacitance is measured by opening the leads at the trips, recording the open circuit value and subtracting that value.
- (e) Capacitors, especially electrolytic, often have notoriously wide tolerances. Do not be surprised if the measured value is greater than the value marked on the capacitor, unless it is a close tolerance type. However, value is seldom drastically below the rated value.
- (f) If changing range, measured value will be changed, leakage-voltage capacitors will be checked also. Leakage-resistance will be decreased in lower range.

5. MAINTENANCE

1) 9-Volt battery replacement

- a. Ensure the instrument is not connected to any external circuit. Set the selector switch to OFF position and remove the test leads from terminals.
- b. Remove the screw on the bottom case and lift the bottom case.
- c. Remove the spent battery and replace it with a battery of the same type.

2) Fuse replacement

- a. Ensure the instrument is not connected to any external circuit. Set the selector switch to OFF position and remove the test leads from terminals.
- b. Remove the screw on the bottom case and lift the bottom case.
- c. Replace the fuse with the same type and rating: 5X20mm, 200mA/250V, fast-blow fuse or as the replacements.