

# USER MANUAL

## Digital Multimeter

Model MDM8145A, MDM8146A, MDM8155A

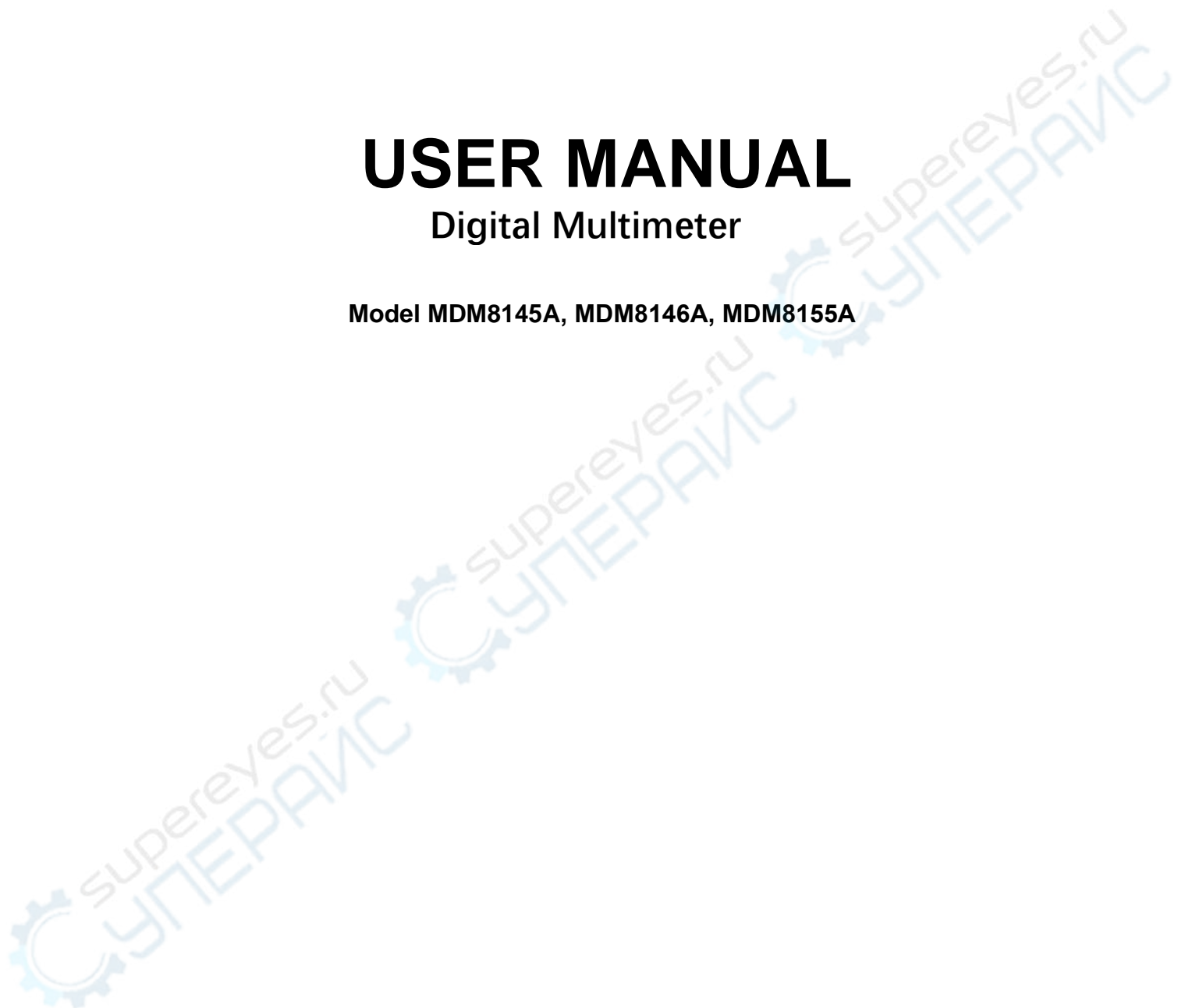

---

© Copyright belongs to Matrix

# Contents

1. Safety Notices .....	2
2. Introduction .....	5
3. General indicators .....	7
4 Quick reference .....	7
4.1 Check the accessories of the product .....	7
4.2 The front panel at a glance .....	8
4.3 Introduction to keys .....	9
4.4 Introduction to the display .....	14
4.5 Introduction to the back panel .....	15
4.6 Adjustment of handle .....	16
4.7 Turn on the multimeter .....	17
5 Instruction on measurement .....	17
5.1 Voltage measurement .....	18
5.2 Current measurement .....	20
5.3 Resistance measurement .....	23
5.4 Capacitance measurement .....	25
5.5 Frequency measurement .....	26
5.6 Diode and on-off test .....	27
5.7 Duty cycle measurement .....	29
5.8 Square wave output .....	30
6 Technical indicators .....	32
7 Calibration .....	36
8 Communication interface .....	43
9. Installation and use of relevant software .....	44
10. Maintenance and upkeep .....	44

# 1. Safety Notices

To avoid personal injury and prevent damage to the product, be sure to use this product in accordance with the manual. Before fully understanding and meeting the following warning, do not proceed to the next step.

- ◆ **Safety ground.** The safety ground must be firmly connected to the ground pin at the power outlet and insert the instrument plug into a grounded outlet.
- ◆ **Use proper fuses.** To provide continuous fire protection, use only the specified type and rating fuses.
- ◆ **Proper use of lead set.** Do not use damaged or worn test lead set. It may result in damage to the instrument or personal injury. When using probes, the finger should be kept behind the finger protector of the probe. When wiring, should connect the common line first and then connect the charged test lead. When disconnecting, disconnect the charged test lead first.
- ◆ **If the product malfunctions, do not use.** Its protection may be impaired, do not install substitute parts or perform any unauthorized modification to the product. Please return the product for repair or to be checked by a professional inspection to ensure product's safety features.
- ◆ **Do not use this product at high temperature, or environment with explosives or strong electromagnetic field.**
- ◆ **Do not change the internal wiring inside of instrument, so as not to damage the instrument or cause other endanger the safety of things.**
- ◆ **When measuring, the correct measurement function and range must be selected.**
- ◆ **Before the function range is switched, to prevent damage to the instrument, the probe and the measured circuit should be disconnected to prevent damage to the instrument.**
- ◆ **Protection limits.**

□ The Digital Multimeter provides protection circuitry to prevent damage to the instrument and to protect against the danger of electric shock provided the Protection Limits are not exceeded. To ensure the safe operation of the instrument, do not exceed the Protection Limits shown on front and back panels, and defined as follows:

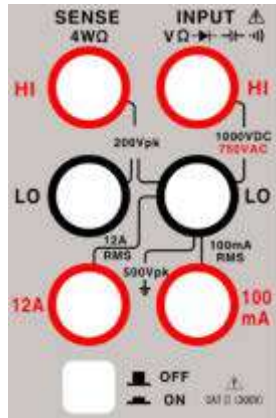

**Table 1 Different functions of input terminals**

Measurement function	Input terminals		Overload protection
DC voltage	INPUT V Ω Hz	INPUT LO	1000V DC or 750V AC
AC voltage	INPUT V Ω Hz		1000V DC or 750V AC
Frequency	INPUT V Ω Hz		250V DC and AC peak
2W resistance	INPUT V Ω Hz		1000V DC or 750V AC
Capacitance	INPUT V Ω Hz		250V DC and AC peak
Diode and on-off	INPUT V Ω Hz		250V DC and AC peak
AC and DC current mA	mA		Overload protection: 500mA/250V fuse, 11A/250V fuse
AC and DC current A	10A		
4W resistance	SENSE HI INPUT HI	SENSE LO INPUT LO	250V DC and AC peak

**Notes:**

In order to avoid blown fuse or damage to the meter, be sure to follow these tips to use the current input terminals.

- 1) 10 A and 200 mA input terminals are not allowed to simultaneously connect to the current measurement circuit.
- 2) If the effective value of the measured current AC + DC is within the range from 200 mA to 10 A, only 10A and LO terminals are allowed to be used in the measurement.
- 3) When the measurement of current is conducted, before the multimeter is powered

on, be sure to select the proper current input terminals based on the estimation.

4) The current input to the terminal 10 A must not exceed 11 A; otherwise, the internal fuse inside the multimeter will blow; and the current input to 200 mA terminal must not exceed 500 mA; otherwise, the current input fuse on the back panel will blow.

#### ◆ IEC Measurement Category II Overload Protection

To protect against the danger of electric shock, this product provides overload protection for line-voltage mains connections meeting both of the following conditions:

1 . The HI and LO input terminals are connected to the mains under the Measurement Category II (as described below) conditions.

2 . The mains are limited to a maximum line voltage of 300 VAC.

Warning: IEC Measurement Category II includes electrical devices connected to mains at outlet on a branch circuit. Such devices include most small appliances, test equipment, and other devices that plug into a branch outlet socket.

This product can be used for such measurements: HI and LO inputs are connected to mains of such devices (up to 300 VAC), or to the branch outlet. However, this product may not be used with its HI and LO inputs connected to the mains in permanently installed electrical devices, such as the main circuit-breaker panel, sub-panel disconnected boxes, or permanently wired motors. Such devices and circuits are subject to over voltages that may exceed the protection limits of this product.

Notes: Voltages above 300 VAC can be measured only in circuits that are isolated from mains. However, transient over voltages are also present on circuits that are isolated from mains. This product is designed to safely withstand occasional transient over voltages up to 2500Vpk. Do not use this equipment to measure circuits where transient overvoltages could exceed this level.

## Environment related notes

This product complies with the WEEE Directive (2002/96 / EC) marking requirement.

The affixed product label (see below) indicates that you must not discard this electrical / electronic product in domestic household waste.



**Product category:** With reference to the equipment types in the WEEE directive Annex 1, this product is classified as a "Monitoring and Control instrumentation" product.

This product may contain substances that might be harmful to the environment or

human health; in order to avoid the release of hazardous substances into the environment or harm to human health, we recommend the use of appropriate methods to recycle this product in order to ensure that most of the materials are reused or recycled. For disposal or recycling related information, please contact the local authorities.

## Safety Symbols

The following signs might be seen on the product:

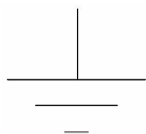

Earth ground

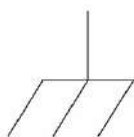

Chassis ground



Risk of electric shock



Refer to manual for additional safety information

## 2. Introduction

MDM8145A / MDM8146A / MDM8155A is a full-featured, 19999 counting 4½ digit (MDM8145A / MDM8146A) / 199999 counting 5½ digits (MDM8155A) desk-type true-RMS digital multimeter with stable performance. The STM32 chip and external integration AD chip used by the meter offer strong overall functionality, excellent performance, and good experience for users; its 3.5-inch large-screen has clear displays of reading, rich content, and a good result of display. It is mains-powered driving which makes it highly reliable. Its comprehensive features, full-range overload protection and unique design make it the first choice for electricians and university laboratories.

In addition, MDM8145A / MDM8146A / MDM8155A are equipped with the calibration function which allows the user to calibrate according to actual needs and is simple and convenient.

### Basic features

- 5½-digit resolution ratio (MDM8155A) / 4½-digit resolution ratio (MDM8145A / MDM8146A).
- 3.5-inch large-screen display with rich content, clear display of reading, and a good result of display.
- Dual parameter display: it can display two parameters of the same input signal (for example, with the AC voltage measurements, it can display simultaneously AC voltage and AC frequency value).

- Measurement speed points: FAST (6 times / second) → MID (4 times / sec) → SLOW (1 times / sec).
- Duty cycle measurement function
- Square wave output function (MDM8145A and MDM8146A optional)
- Manual / automatic range setting function
- Communication interfaces: USB Device, RS232 (MDM8145A and MDM8146A optional).
- Support SCPI protocol and provide programming file
- AC and DC voltage, DC current, two-wire / four-wire resistance measurement.
- Cycle and frequency measurement, frequency of up to 20MHz.
- Capacitance measurement.
- Provide automatic trigger, external trigger, and single trigger measurements. (External trigger optional for the MDM8145A and MDM8146A models).
- Measurement capabilities for current up to 10A and voltage up to 1000V DC.
- Keypad lock function and system setup; languages, buzzer, screen brightness and so on can be configured according to various needs.
- Simple external calibration function
- Variety of mathematical functions: statistics (maximum, minimum), relative measurement, dB, dBm.
- On-off, diodes, reading hold, data hold / reading, key tone, trigger measurement and so on.

## 3. General indicators

1-1 Mode of display: 3.5-inch LCD display;

1-2 Maximum display: 220 000 (5 1/2) automatic polarity display and unit digit display;

1-3 Range selection: automatic / manual;

1-4 Note to over-range: the screen displays "-OL-";

1-5 Measuring rate: fast (6 times / sec), medium (4 times / sec), slow (1 times / sec);

1-6 Power supply voltage: AC 220V  $\pm$  10%, 50Hz;

1-7 Working environment: (0 ~ 40) °C, relative humidity <80%;

1-8 Storage environment: -10 ~ 50 °C, relative humidity <80%;

1-9 Dimensions: 265mm x 105mm x 330mm (width X height X depth);

10 Weight: 2.3kg;

## 4 Quick reference

### 4.1 Check the accessories of the product

Confirm the following accessories of the multimeter, among which the optional accessories are delivered if only ordered. If any items are missing, please contact the nearest sales office.

#### 4½ digits standard accessories:

- a pair of probes
- a double end three-wire power line
- two backup power fuses
- MDM81 user's manual

#### 5½ digits standard accessories:

- a pair of probes
- a double end three-wire power line
- a CD-ROM



- two backup power fuses
- MDM81 user's manual

Optional accessories:

- RS232 serial line
- USB cable

### Standard and optional function / information of communication interface

Function/communication interface	Four and a half digits	Five and a half digits
USB Device	Standard	Standard
RS232	Optional	Standard
Square wave output	Optional	Standard
External trigger	Optional	Standard

## 4.2 The front panel at a glance

The front panel of the table-type multimeter is shown in Figure 1.1.1.



Figure 1.1.1 Sketch map of front panel

Table 1.1.1 Description of each module of front panel

No.	Description
1	measurement terminal of multimeter
2	display screen
3	basic measurement function keys
4	parameter selection Enter keys
5	mathematical function keys
6	additional function keys
7	power key

## 4.3 Introduction to keys

See Figure 1.2.1 for keys:

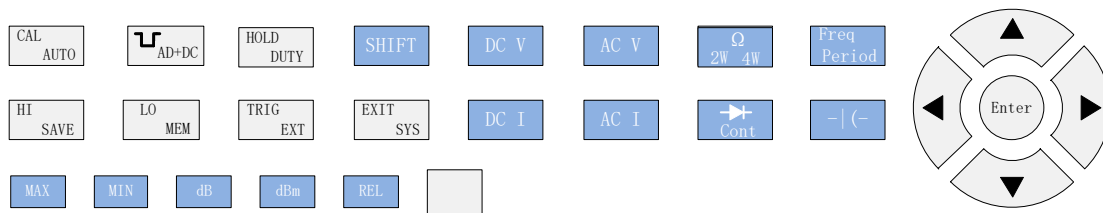



Figure 1.2.1 Keys

Switch of multimeter

Press the key  to turn on or off the meter.

The basic measurement function keys

 Press the key to enter the DC voltage measurement interface;

 Press the key to enter the AC voltage measurement interface;

 Press the key to enter the DC current measurement interface;

 Press the key to enter the AC current measurement interface;

 Press the key to enter 2W resistance measurement interface, and press this key again to enter 4W resistance measurement interface;

 Press the key to enter capacitance measurement interface;

 Press the key to enter frequency measurement interface, and press this key again to enter the cycle measurement interface;

 Press the key to enter the diode measurement interface, and press this key again to enter the on-off measurement interface;

### Parameter selection keys

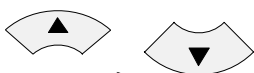

Function:

1. Press the key to switch from automatic range to manual range and switch the range;
2. Adjust the frequency of the square wave output;
3. Browse the stored data;
4. Adjust the upper and lower limits;

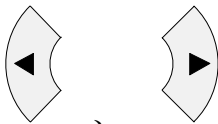

Function:

1. Change the measurement speed;
2. Select the position where the square wave needs adjustment;
3. Select the position where the upper and lower limits need adjustment;



Function:

1. Enter key.
2. Proceed to set the frequency of the square-wave
3. Proceed to set the limits

## Additional function keys



Press the key to start duty cycle measurement;



Single-trigger key, each time it is pressed, it measures and displays for one time;



1. When the range is in manual mode, press the key to switch to the automatic range;

2. When the trigger mode is not automatic, press this key to switch to the automatic trigger;



Square wave output key, press the key to output a square wave signal with fixed amplitude and tunable frequency. Press the Enter key to enter the frequency adjustment, control the arrow keys to adjust, and then press the Enter key after the adjustment is done. (five and a half digits standard, four and a half digits optional, and peripheral circuit is required)



Press the key to enter the data storage mode, and press the key again to exit the data storage mode. When it is in data storage mode, every time the measurement is done, the measured data and the current measurement configuration will be written into the cache, and the storage number will be displayed. In the meantime, you can switch to a different measurement function (storage is not supported for some functions, such as diodes, duty cycle, on-off measurement, etc.); for each measurement function the measurement data will be saved. When the key is pressed to exit the storage mode, the system automatically writes the data in the cache into FLASH. There can be up to 600 storage data, when there are more than 600 data, it will save the 600 data from the latest one. However, the counting starts again from 1 because there are more than 600 data displayed.



Data reading key, press the key to enter the data reading mode, and press the other keys (DCV, DCI and the like) or Exit (SHIFT + EXIT) to exit. When entering the data reading mode, the first display is the last number of the last saved data. In addition to the data on the main display, the serial number of the last saved data and some measurement configuration (measurement function, range, measurement rate, trigger mode and additional functions) will be displayed on the secondary display. Press the arrow keys to browse the saved data. The latest saved is seen first in the reading

mode; so there is no need to browse the following data. When the saved number exceeds 600, for example 65-, then the 650<sup>th</sup> data is shown when entering the reading mode, and 50 is shown on the secondary display. The number decreases on the second display when browsing the previous data. When 1 is shown on the secondary display, then browse the previous data and it will display 600. That is to say, saving and reading are conducted in circular manner.

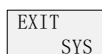

System information checking setting key, press the key to view the current model, serial number, software version, and language, buzzer, screen brightness and so on can be set. Use the arrows keys to select and change.



### Second function enable key



Reading hold function, press the key combination, the reading on the meter remains; and press the key combination again to exit the reading hold function.



AC + DC measurement function, press the key combination to start AC + DC signal measurement; press the key combination again to exit the reading hold function. (The function cannot be applied currently)



External trigger function, press the key combination to enter the external trigger measurement mode; when a low pulse flows through the external trigger terminal, the system measures one time; press the key combination again to exit the external trigger function. (MDM8155A standard function, MDM8145A / MDM8146A optional function)



Calibration function, press the key combination to enter the calibration mode. However, the calibration function is related to what the measurement function is when entering the calibration mode. For example, when the current measurement function is DCV, then press the key combination and it will enter the calibration mode of DCV. The measurement functions which support calibration function are: DC/AC voltage, DC/AC current, two- and four-wire resistance, capacitance.

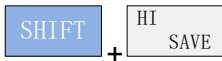

Upper limit comparison function, which is only effective in case of AC and DC voltage. When it is switched to the AC and DC voltage measurement function, press the key combination to enter the upper limit comparison function and the default comparison value is 1V; press the Enter key to set the comparison value, press the arrow keys to change the comparison value, and then press Enter to complete the setting. When the displayed value is larger than the comparison value, the buzzer will ring out; otherwise, it will not.

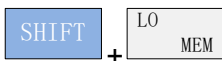

Lower limit comparison function, which is only valid in case of AC and DC voltage. In the AC and DC voltage measurement function, press the key combination to enter the lower limit comparison function and the default value is 1V; press Enter to set the comparison value, and press the arrow keys to change the comparison value, then press Enter to complete the setting. When the displayed value is larger than the comparison value, the buzzer will ring out; otherwise, it will not.



Exit key, press the key combination to exit from all additional functions and return to DC voltage measurement interface in any state or in case of any function.

## Mathematical function key



Press the key and dB value will be shown on the secondary display; it is only valid in case of the AC and DC voltage measurement function.  $\text{dB value} = \text{dBm value of the reading} - \text{dBm value of the relative value}$ ;



Press the key and dBm value will be shown on the secondary display; it is only valid in case of the AC and DC voltage measurement function.  $\text{dBm} = 10 \times \log_{10}(\text{reading}^2 / \text{reference resistor} / 1\text{mW})$ ;



Relative measurement key, press the key, and it will record the current value, and the displayed value afterward = actual measured value - current recorded value;

**MAX** Maximum measurement key; press the key, and the system will determine according to the measured values, and the maximum value is displayed on the secondary display

**MIN** Minimum measurement key; press the key, and the system will determine according to the measured values, and the minimum value is displayed on the secondary display

## 4.4 Introduction to the display

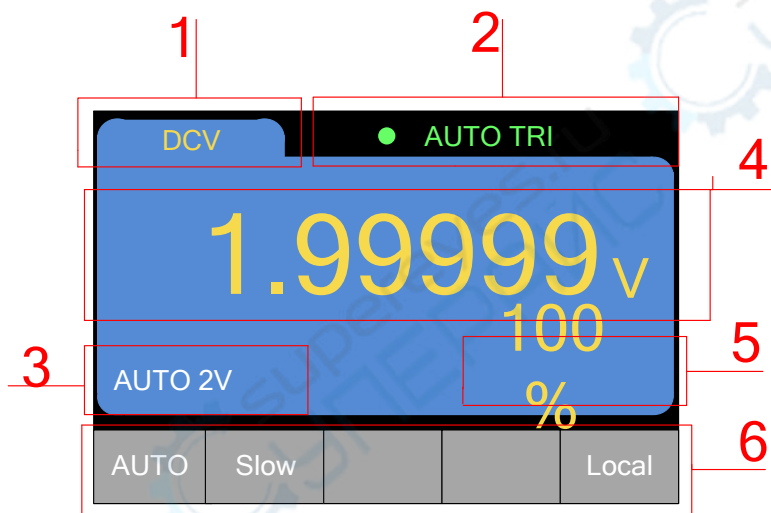

**Figure 1.3.1 Interface of the display**

**Table 1.3.1 Interface Module Description**

No.	Note
1	displays the function currently under operation
2	displays the mode of trigger: automatic trigger, single trigger, external trigger
3	only displays when it is in the automatic range and hint at the currently corresponding range
4	main display
5	secondary display
6	measurement configuration column

### Details of measurement configuration column

The first pane displays the range: take the DC voltage for example, there are modes

such as automatic (AUTO), 200mV, 2V, 20V, 200V, 1000V. When in automatic (AUTO) mode, the information represented by the number 3 appears.

The second pane shows the measurement speed: There are three kinds of measurement speeds to choose from—slow (SLOW), Medium (MIDDLE), fast (FAST).

The third and fourth panes are mainly used to display the operation function, when running the functions such as save (SAVE), (read) MEM, compare (COMP), external trigger (EXT), and DC + AC, the corresponding function information is shown on the third and fourth panes.

The fifth pane displays whether the mode is local or remote.

## 4.5 Introduction to the back panel

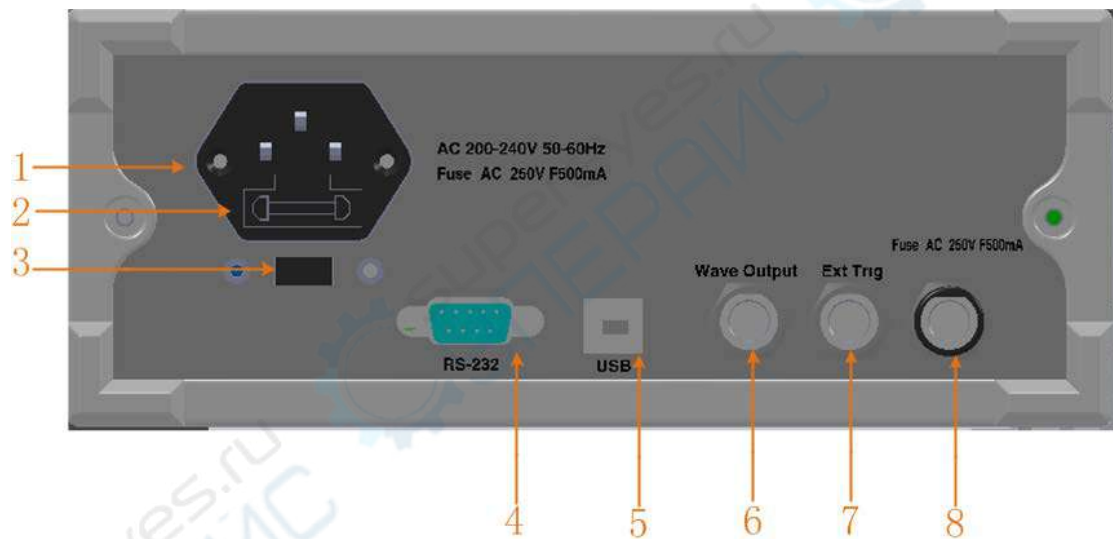

Figure 1.5.1(1) Sketch map of five and a half digits back panel

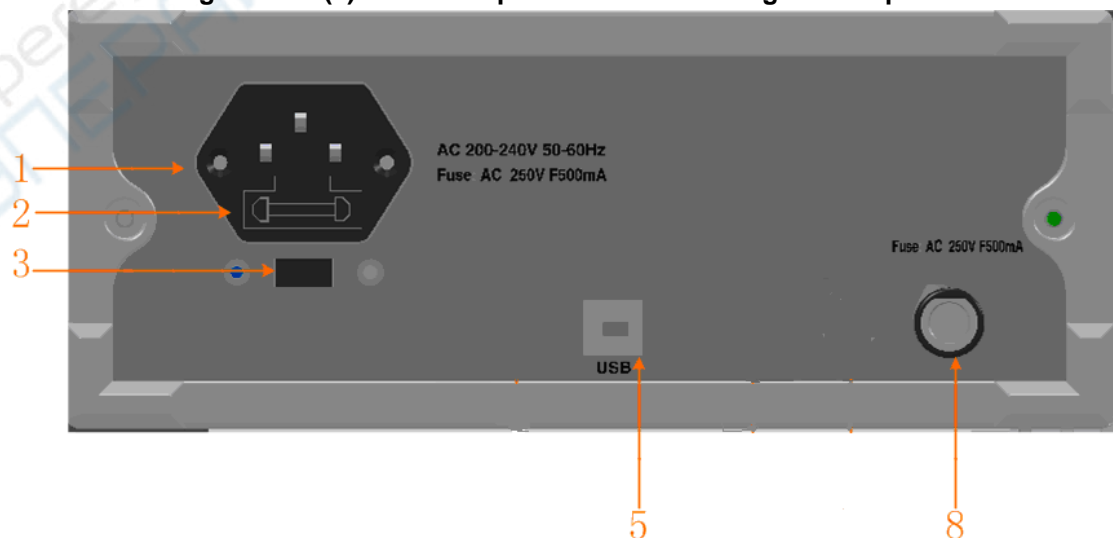



Figure 1.5.1(2) Sketch map of four and a half digits back panel

Table 1.5.1 Description of back panel

No.	Description
1	supply hub: AC 220V/50Hz power supply input socket
2	power fuse: 0.5A/250V fuse
3	voltage selector: 110V/50Hz VAC or 220V/50Hz VAC
4	RS232 interface (MDM8145A/MDM8146A optional)
5	USB Device interface
6	square wave output terminal (MDM8145A/MDM8146A optional)
7	external trigger measurement port (MDM8145A/MDM8146A optional)
8	current input fuse: 0.5A/250V fuse

## 4.6 Adjustment of handle

To adjust the carrying handle of the digital multimeter, hold the handle by the sides and pull it outward. Then rotate the handle to the required position. See the figure below for the operation method

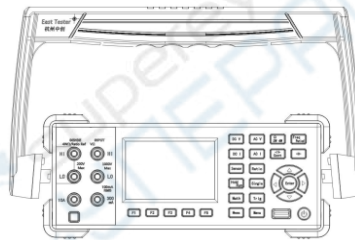

Adjust Handle

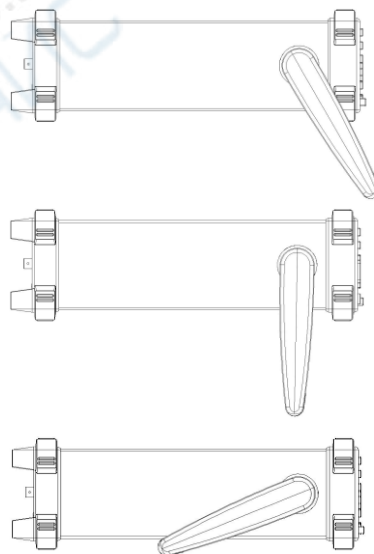

Working position



Carrying position

## 4.7 Turn on the multimeter

1. Connect the AC power supply

1) The power supply of 110V or 220V for the multimeter can be selected, adjust the voltage selector on the back panel of the multimeter according to the power supply.

2) Use the power line provided to connect the multimeter to AC power.

2. Start multimeter

Turn on the power switch below the power socket.

3. If the instrument does not start, check according to the following steps:

1) Check if the power line has a good contact.

2) Check if the back panel is turned on.

3) If there is no problem after the inspection, and the instrument still does not start, check if the power fuse is blown; if necessary, replace the fuse.

4) If after the above checks, the instrument still does not start, please contact the relevant department.

## 5 Instruction on measurement

Notes:

1. After the voltage up to 1000 VDC is measured, it is better to wait for about 2 minutes, and then conduct the low voltage measurement with the resolution rate 1 to 10  $\mu$ V.

2. After using the A input terminal for measuring high currents, it is better to wait for about 10 minutes, and then conduct the low-level DC measurements (volts, amps, or ohms) in order to achieve accuracy. The reason is that measuring the thermal voltage generated by the high current may cause errors in the low-level measurements.

3. After the completion of all measurements, disconnect the probe and the circuit under test and remove the probe from the input end of the instrument.

4. When measuring the high voltage and high current, pay special attention to safety.

5. Because MDM8145A / MDM8146A / MDM8155A share the same measurement method, the measurement will be explained by taking the operation of MDM8155A as an example.

## 5.1 Voltage measurement

Notes: Make sure that before the measurements, the terminals are connected correctly. To avoid damages to the multimeter, do not exceed the rating.

### 5.1.1 DC voltage measurement

Range: 200mV, 2V, 20V, 200V, 1000V

Input protection: the peak of 1000V for all ranges

Measurement method:

1. Press  to select DC voltage measurement function; it automatically enters into DC voltage measurement function every time when the instrument is turned on.

The DC voltage measurement interface is shown in Figure 2.1.1:



**Figure 2.1.1 DC Voltage Measurement**

Notes: the measured voltage value is shown on the main display, and the value on the secondary screen represents the ratio of the current measured value and the full scale.

2. According to Figure 2.1.2, connect the red and black test leads respectively to the proper input terminals.
3. Probe the test points and read the display.

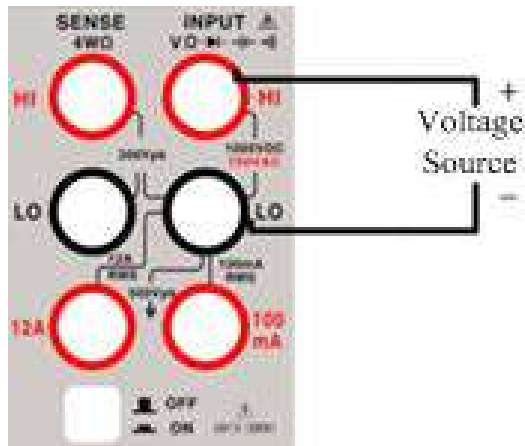

Figure 2.1.2 DCV terminal connection

### 5.1.2 AC voltage measurement

Note: To ensure accuracy, the input value should be greater than 10% of the range.

Range: 200mV, 2V, 20V, 200V, 750V

AC technology: True RMS measurement

Input protection: RMS of 750V for all ranges.

Measurement method:

1. Press AC V to select AC voltage measurement function. The AC voltage measurement interface is shown in Figure 2.1.3:



Figure 2.1.3 AC Voltage Measurement

Note: the measured voltage value is shown on the main display, and the value on the secondary screen represents the measured frequency of the current input signal.

2. According to Figure 2.1.4, connect the red and black test leads respectively to the proper input terminals.

3. Probe the test points and read the display.

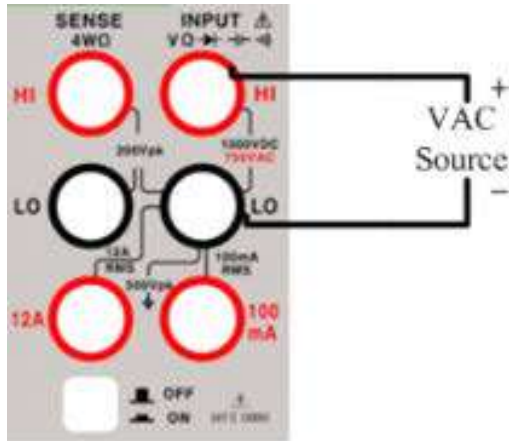

Figure 2.1.4 ACV terminal connection

## 5.2 Current measurement

### 5.2.1 DC current measurement

Current measurement is designed for low and high current respectively with different methods of connection.

Range for low current: 200uA, 2mA, 20mA, 200mA

Range for high current: 2A, 10A.

Measurement method:

1. Press DC I to select DC current measurement function. The DC current measurement interface is shown in Figure 2.2.1:



Figure 2.2.1 DC Current Measurement

Notes: the measured voltage value is shown on the main display, and the value on the secondary screen represents the ratio of the measured value and the full range

2. Choose different test terminal according to the measurement level. See Fig. 2.2.2

for current of 200mA and below, and connect the red and black test leads respectively to the proper input terminals. See Fig. 2.2.3 for current from 200mA to 10A, and connect the red and black test leads respectively to the proper input terminals.

3. Probe the test points and read the display.

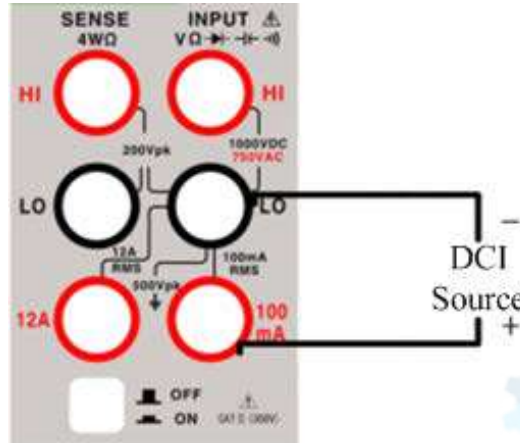

Figure 2.2.2 Method of connecting test terminals for low current

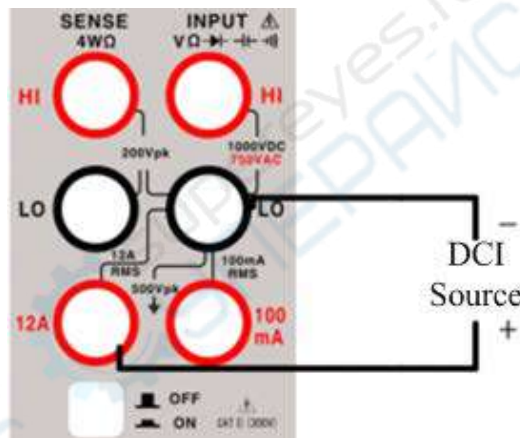

Figure 2.2.3 Method of connecting test terminals for high current

### 5.2.2 AC current measurement

Current measurement is designed for low and high current respectively with different methods of connection.

Range for low current: 200uA, 2mA, 20mA, 200mA

Range for high current: 2A, 10A.

Measurement method:

1. Press AC I to select AC current measurement function. The AC current measurement interface is shown in Figure 2.2.4:

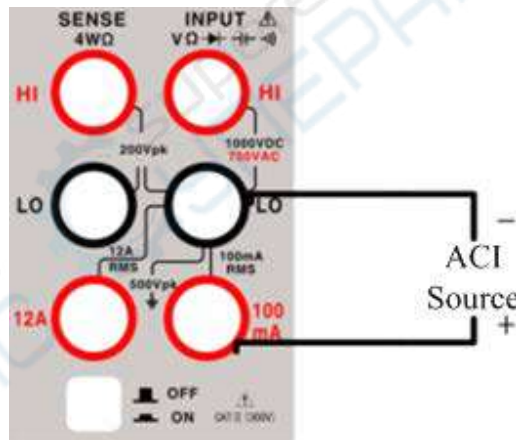

**Figure 2.2.4 AC Current Measurement**

Notes: the measured current value is shown on the main display, and the value on the secondary screen represents the measured frequency of the current input signal

2. Choose different test terminals according to the measurement level. See Fig. 2.2.5 for current of 200mA and below, and connect the red and black test leads respectively to the proper input terminals. See Fig. 2.2.6 for current from 200mA to 10A, and connect the red and black test leads respectively to the proper input terminals.

3. Probe the test points and read the display.



**Figure 2.2.5 Method of connecting test terminals for low current**

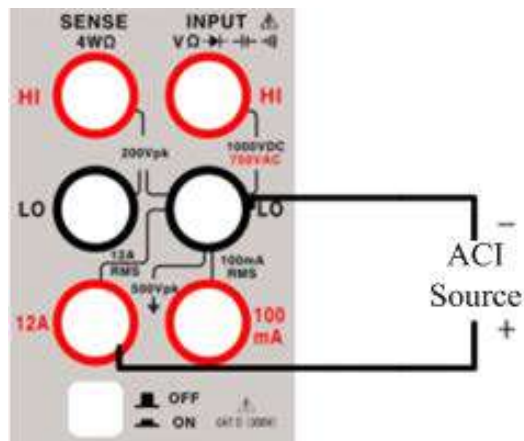

Figure 2.2.6 Method of connecting test terminals for high current

## 5.3 Resistance measurement

Note: Before measuring the resistance, disconnect the circuit power and discharge all high-voltage capacitors to avoid damages to the multimeter or the multimeter tested.

Range: 200 $\Omega$ , 2k $\Omega$ , 20k $\Omega$ , 200k $\Omega$ , 2M $\Omega$ , 20M $\Omega$

Measurement method:

### 5.3.1 2-wire resistance measurement

1. Press  to select the default 2-wire resistance measurement function. The 2-wire resistance measurement interface is shown in Figure 2.3.1:



Figure 2.3.1 2-wire resistance measurement interface

Notes: the measured voltage value is shown on the main display, and the value on the secondary screen represents the ratio of the current measured value and the full range.

2. According to Figure 2.3.2, connect the red and black test leads respectively to the proper input terminals.
3. Probe the test points and read the display.



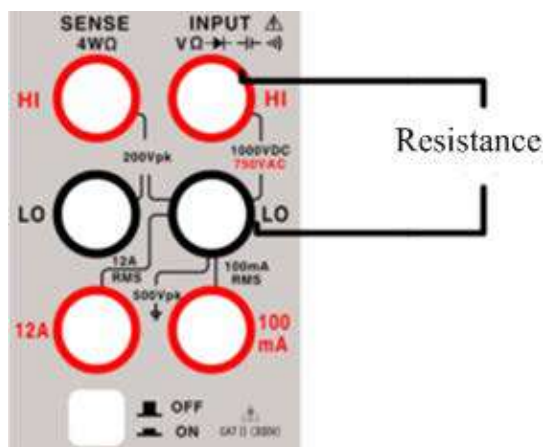

Figure 2.3.2 2W resistance measurement terminal connection

### 5.3.2 4-wire resistance measurement

1. When in the mode of 2-wire resistance measurement, press Ω  
2W 4W again to select four-wire resistance measurement. The four-wire resistance measurement interface is shown in Figure 2.3.3:



Figure 2.3.3 4-wire resistance measurement interface

Note: the measured voltage value is shown on the main display, and the value on the secondary screen represents the ratio of the current measured value and the full range.

2. According to Figure 2.3.4, connect the red and black test leads respectively to the proper input terminals.

3. Probe the test points and read the display.

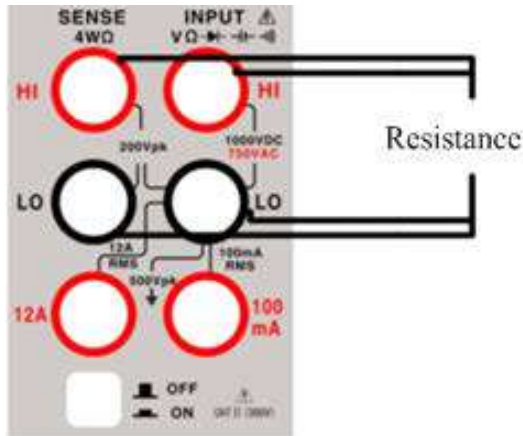

Figure 2.3.4 4W resistance measurement terminal connection

## 5.4 Capacitance measurement

Range: 20nF, 200nF, 2uF, 20uF, 200uF, 2mF, 10mF

Measurement method:

1. Press  to select the frequency measurement function. The capacitance measurement interface is shown in Figure 2.4.1:



Figure 2.4.1 Capacitance measurement interface

Note: the measured capacitance value is shown on the main display, and the value on the secondary screen represents the ratio of the current measured value and the full range.

2. According to Figure 2.4.2, connect the red and black test leads respectively to the proper input terminals.
3. Probe the test points and read the display.

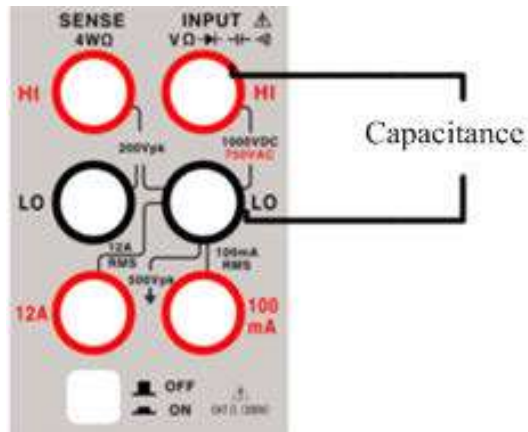

Figure 2.4.2 Capacitance measurement terminal connection

## 5.5 Frequency measurement

Range: 20Hz, 200Hz, 2kHz, 20kHz, 200kHz, 2MHz, 20MHz

Input sensitivity: 1.5V RMS

Measurement method:

1. Press Freq  
Period to select the frequency measurement function or cycle measurement. The frequency / cycle measurement interface is shown in Figure 2.5.1:

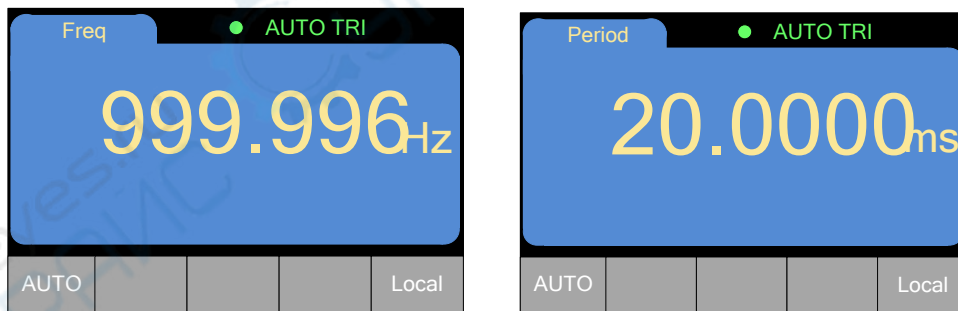

Figure 2.5.1 (1) frequency measurement interface

Figure 2.5.1 (2) cycle measurement interface

Notes: when measuring frequency or cycle, the value on the secondary screen represents the RMS of AC voltage of the input signal.

2. According to Figure 2.5.2, connect the red and black test leads respectively to the proper input terminals.
3. Probe the test points and read the display.

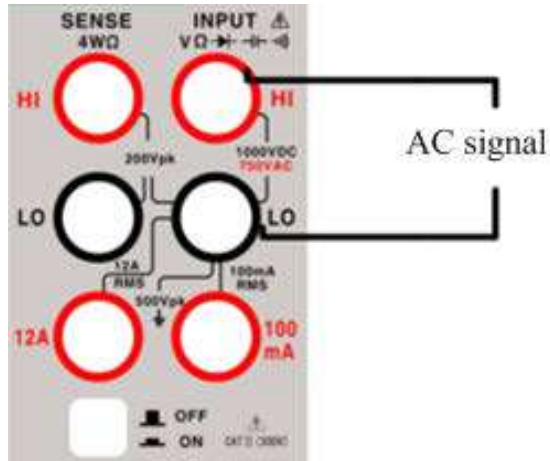

Figure 2.5.2 Frequency/cycle measurement terminal connection

## 5.6 Diode and on-off test

The measurement value is the forward voltage drop approximation, when the measured resistance is smaller than  $(30) \Omega$ , the buzzer rings out, and displays the approximation; the voltage of the open circuit is about 2.8V

Test condition: the forward DC current is approximately 1mA, and the reverse DC voltage no higher than 3V.

### 5.6.1 Diode measurement

1. Press  and the default is diode measurement function. When the voltage is higher than the measurement threshold, it displays OPEN, otherwise it displays the measured voltage value. The measurement threshold for diode is 3V. The diode measurement interface is shown in figure 2.6.1:



Figure 2.6.1 Diode measurement interface

2. According to Figure 2.6.2, connect the red and black test leads respectively to the proper input terminals.

3. According to Figure 2.6.2, connect the test leads to the terminals of the diode and read the display.

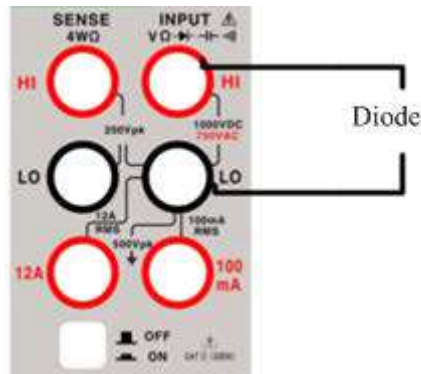

**Figure 2.6.2 Diode measurement terminal connection**

### 5.6.2 On-off Test

1. When in the diode test mode, press  to select the on-off measurement. When the measured resistance value is greater than the threshold of the buzzer, it displays OPEN, and when the measured resistance value is smaller than the threshold of the buzzer, the resistance will be displayed. The threshold of the buzzer is 10Ω. The on-off measurement interface is shown in Figure 2.6.3:



**Figure 2.6.3 On-off measurement interface**

2. According to Figure 2.6.4, connect the red and black test leads respectively to the proper input terminals.

3. Probe the test points and when the measured resistance is lower than the threshold of the buzzer, the buzzer rings out.

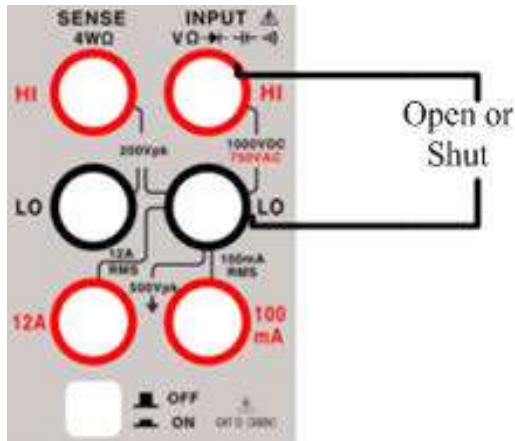

Figure 2.6.4 On-off measurement terminal connection

## 5.7 Duty cycle measurement

1. Press  to enter the duty cycle measurement, and the duty cycle measurement interface is shown in Figure 2.7.1.



Figure 2.7.1 Duty cycle measurement interface

2. According to Figure 2.7.2, connect the red and black test leads respectively to the proper input terminals.

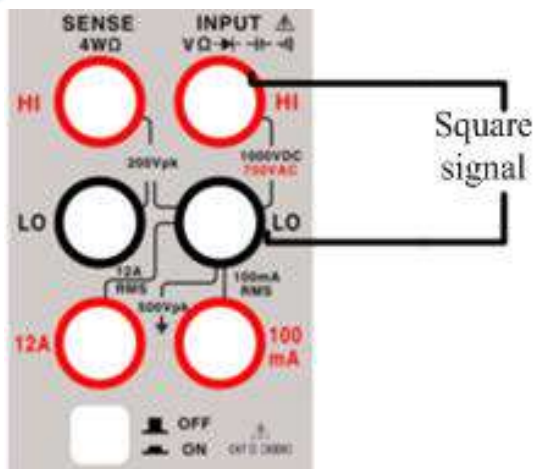

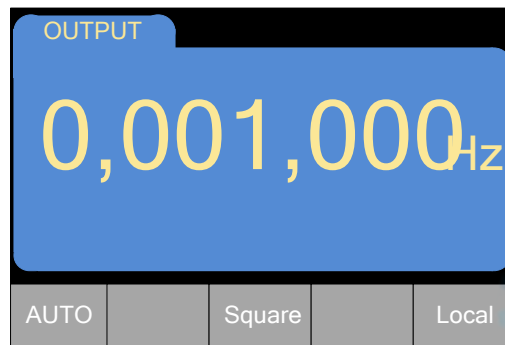

Figure 2.7.2 Five and a half digits duty cycle measurement terminal connection

## 5.8 Square wave output

Press  to turn on the square wave output function and the mark of square wave (SWave) will appear in the measurement configuration bar. When it is turned on, the square wave is output directly. In this case, the screen displays the square wave output frequency, and the default frequency is 1kHz, as shown in Figure 2.8.1.





**Figure 2.8.1 Square wave interface with a default output frequency of 1kHz**

Square wave output frequency can be set by users, and the method is as follows:

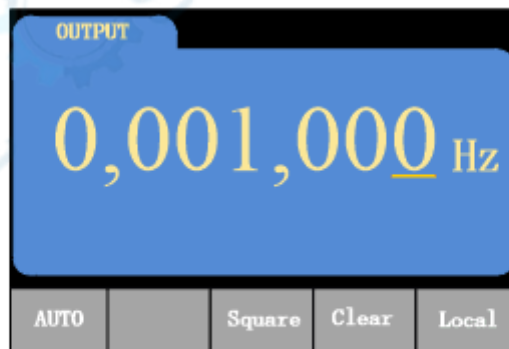
When the frequency is set, the adjustment position default is the lowest level, and the selected location has a crossbar below, shown in figure 2.8.2;





**Figure 2.8.2 Entering the frequency adjustment interface**

Press  and  to select where the square wave output frequency needs to

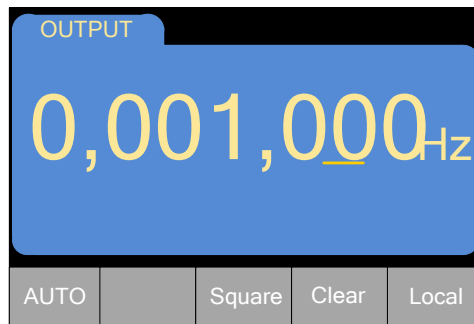
be adjusted and the selected location has a crossbar below, shown in figure 2.8.3;



**Figure 2.8.3 Interface to select the adjustment position**

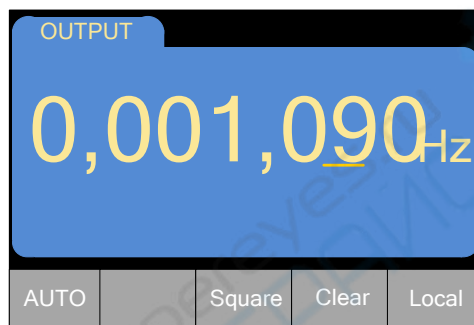

Press  and  to adjust the square wave output frequency, as shown in figure 2.8.4;



**Figure 2.8.4 Interface to adjust the specific frequency**

The square wave output frequency is set up, and the square wave is output from the

terminal  on the back panel.

Press  +  to exit the square wave output interface to the interface of last measurement. For example, after the DC voltage is measured shown in figure 2.8.5.

Press the square wave enter key to enter into the interface in figure 2.8.1 to change the output frequency of the square wave again or turn off the square wave output. Press

 +  to turn off the square wave output, shown in figure 2.8.6.





**Figure 2.8.5 Switch from the interface of square wave output to that after the measurement of DC voltage**



**Figure 2.8.6 The interface of the latest measurement function after exiting from the square wave output**

## 6 Technical indicators

Limits of error:  $\pm$  (a% reading + digits), guarantee period of one year

Ambient temperature: 18 ~ 28°C

Humidity: no more than 75% RH

Temperature coefficient: 0.1x precision / 1°C

Preheating time: 1 hour

1. DC voltage measurement

Range	Range of measurement	Resolution ratio	Limits of error		
			MDM8145A	MDM8146A	MDM8155A
200 mV	1uV~220.000 mV	1uV	$\pm (0.05\%+4)$	$\pm(0.03\% +10)$	$\pm (0.015\%+4)$
2V	10uV~2.2000 0V	10uV	$\pm (0.05\%+3)$	$\pm(0.03\% +6)$	$\pm (0.015\%+3)$
20V	100uV~22.00 00V	100uV	$\pm (0.05\%+4)$	$\pm(0.03\% +6)$	$\pm (0.015\%+4)$
200 V	1mV~220.000 V	1mV	$\pm (0.05\%+3)$	$\pm(0.03\% +6)$	$\pm (0.015\%+3)$
100 0V	10mV~1000V	10mV	$\pm (0.1\%+3)$	$\pm(0.03\% +6)$	$\pm (0.015\%+3)$

## 2. AC voltage measurement (True RMS)

Range	Resolution ratio	Limits of error (MDM8155A)			
		40Hz~5kHz	5~30kHz	30~50kHz	50~100kHz
200mV	1uV	$\pm(0.2\%+100)$	$\pm(0.2\%+100)$	$\pm(0.5\%+200)$	$\pm(0.8\%+200)$
2V	10uV	$\pm(0.2\%+100)$	$\pm(0.2\%+100)$	$\pm(0.5\%+200)$	$\pm(0.8\%+200)$
20V	100uV	$\pm(0.2\%+100)$	$\pm(0.8\%+300)$	$\pm(2.5\%+500)$	$\pm(5\%+500)$
200V	1mV	$\pm(0.2\%+200)$	$\pm(0.8\%+450)$		
750V	10mV	40Hz~1kHz	1~2kHz		
		$\pm(0.3\%+200)$	$\pm(0.4\%+200)$		

Range	Resolution ratio	Limits of error (MDM8145A/Range of frequency 50Hz~1kHz)
200mV	10uV	$\pm (0.8\%+80)$
2V	100uV	$\pm (0.8\%+80)$
20V	1000uV	$\pm (0.8\%+80)$
200V	10mV	$\pm (0.8\%+80)$
750V	100mV	$\pm (1\%+50)$

Range	Resolution ratio	Limits of error (MDM8146A)		
		40Hz—1KHz	1KHz—10KHz	10KHz—20KHz
200mV	10uV	$\pm(0.5\% +40)$	$\pm(1\% +40)$	$\pm(2.5\% +40)$

2V	100uV	$\pm(0.5\% +40)$	$\pm(1\% +40)$	$\pm(2.5\% +40)$
20V	1000uV	$\pm(0.5\% +40)$	$\pm(1\% +40)$	$\pm(2.5\% +40)$
200V	10mV	$\pm(0.5\% +40)$	$\pm(1\% +40)$	/
750V	100mV	$\pm(0.5\% +40)$	/	/

### 3. DC current measurement

Range	Range of measurement	Resolution ratio	Limits of error		
			MDM8145A	MDM8146A	MDM8155A
200uA	0.001uA~220.000uA	0.001uA	$\pm (0.35\%+10)$	$\pm(0.15\% +15)$	$\pm (0.05\%+10)$
2mA	0.01uA~2.20000mA	0.01uA	$\pm (0.35\%+10)$	$\pm(0.15\% +10)$	$\pm (0.05\%+10)$
20mA	0.1uA~22.0000mA	0.1uA	$\pm (0.35\%+10)$	$\pm(0.15\% +10)$	$\pm (0.05\%+10)$
200mA	1uA~220.000mA	1uA	$\pm (0.35\%+10)$	$\pm(0.15\% +10)$	$\pm (0.05\%+10)$
2A	0.01mA~2.20000A	10uA	$\pm (0.35\%+10)$	$\pm (0.35\%+10)$	$\pm (0.05\%+10)$
10A	0.1mA~10A	100uA	$\pm (0.8\%+60)$	$\pm(0.5\% +10)$	$\pm (0.2\%+60)$

### 4. AC current measurement (MDM8155A Range of frequency 40~5kHz, others 40~1kHz)

Range	Range of measurement	Resolution ratio	Limits of error		
			MDM8145A	MDM8146A	MDM8155A
200uA	0.001uA~220.000uA	0.001uA	$\pm (0.8\%+80)$	$\pm(0.75\% +20)$	$\pm (0.3\%+400)$
2mA	0.01uA~2.20000mA	0.01uA	$\pm (0.8\%+80)$	$\pm(0.75\% +10)$	$\pm (0.3\%+400)$
20mA	0.1uA~22.0000mA	0.1uA	$\pm (0.8\%+80)$	$\pm(0.75\% +20)$	$\pm (0.3\%+400)$
200mA	1uA~220.000mA	1uA	$\pm (0.8\%+80)$	$\pm(0.75\% +10)$	$\pm (0.3\%+400)$
2A	0.01mA~2.20000A	10uA	$\pm (0.8\%+80)$	$\pm(0.75\% +20)$	$\pm (0.3\%+400)$
10A	0.1mA~10A	100uA	$\pm (1\%+50)$	$\pm(1.0\% +10)$	$\pm (1\%+20)$

### 5. Resistance measurement

Range	Range of measurement	Resolution ratio	Limits of error		
			MDM8145A	MDM8146A	MDM8155A
200Ω	0.001Ω~220.000Ω	0.001Ω	$\pm (0.1\%+20)$	$\pm(0.08\% +10)$	$\pm (0.08\%+50)$
2kΩ	0.01Ω~2.20000kΩ	0.01Ω	$\pm (0.1\%+20)$	$\pm(0.08\% +5)$	$\pm (0.02\%+6)$
20kΩ	0.1Ω~22.0000kΩ	0.1Ω	$\pm (0.1\%+6)$	$\pm(0.08\% +5)$	$\pm (0.02\%+6)$
200kΩ	1Ω~220.000kΩ	1Ω	$\pm (0.1\%+6)$	$\pm(0.08\% +5)$	$\pm (0.02\%+6)$

2MΩ	10Ω~2.20000MΩ	10Ω	±(0.4%+10)	±(0.2%+10)	±(0.04%+8)
20MΩ	100Ω~22.0000MΩ	100Ω	±(0.4%+15)	±(0.35%+10)	±(0.25%+6)

#### 6. Capacitance measurement

Range	Range of measurement	Resolution ratio	Limits of error		
			MDM8145A	MDM8146A	MDM8155A
2nF	0.001nF~2.200nF	0.001nF	±(3.5%+30)	±(2%+5)	±(2%+5)
20nF	0.01nF~22.00nF	0.01nF	±(3.5%+30)	±(2%+5)	±(2%+5)
200nF	0.1nF~220.0nF	0.1nF	±(3.5%+30)	±(2%+5)	±(2%+5)
2μF	1nF~2.200μF	1nF	±(3.5%+30)	±(2%+5)	±(2%+5)
20μF	0.01μF~22.00μF	0.01μF	±(3.5%+30)	±(3%+5)	±(3%+5)
200μF	0.1μF~220.0μF	0.1μF	±(3.5%+30)	±(3%+5)	±(3%+5)
2mF	1μF~2.200mF	1μF	±(4%+10)	±(3%+5)	±(3%+5)

#### 7. Frequency measurement

Range	Range of measurement	Resolution ratio	Limits of error		
			MDM8145A	MDM8146A	MDM8155A
200Hz	0.001Hz~220.000Hz	0.001Hz	±(0.2%+10)	±(0.2%+10)	±(0.1%+3)
2kHz	0.01Hz~2.2000kHz	0.01Hz	±(0.2%+10)	±(0.2%+10)	±(0.1%+3)
20kHz	0.1Hz~22.0000kHz	0.1Hz	±(0.2%+10)	±(0.2%+10)	±(0.1%+3)
200kHz	1Hz~220.000kHz	1Hz	±(0.2%+10)	±(0.2%+10)	±(0.1%+3)
2MHz	10Hz~2.20000MHz	10Hz	±(0.2%+10)	±(0.2%+10)	±(0.1%+3)
20MHz	100Hz~22.0000MHz	100Hz	±(0.2%+10)	±(0.2%+10)	±(0.1%+3)
Duty cycle	5.0%~95.0% (the error is within 10 digits)				

#### 8. Diode measurement

Range	Range of measurement	Input protection	Note
200Ω level	0~2V	250Vp	Input current is

			around 0.75mA
--	--	--	---------------

#### 9. On-off measurement

Range	Range of measurement	Input protection	Limits of error
200Ω level	0~30Ω	250Vp	Input current is around 0.75mA, when the resistance is smaller than 30Ω, the buzzer rings out

#### 10. Square wave output

Output	Output frequency	Output amplitude
Square wave	1Hz~100kHz	3V

## 7 Calibration

**Note 1.** Before calibration, it is required to preheat the instrument for more than 30 minutes. The accuracy of the standard source must be better than 1/3 of the accuracy of the calibrated instrument.

**2.** In order to prevent inaccurate calibration due to wrong operation, it is required to enter a password before the calibration, and the password is 010086.

**3.** Enter the password and enter the calibration interface; take the calibration interface of DCV as an example:



No.	Definition
1	The position represents the current calibration function
2	The position represents the current range of calibration
3	The position represents the current value entered
4	The position is used to input the RMS
5	The position represents the current measurement value

4. The calibration data can only be written into FLASH when all levels are calibrated and the secondary display shows OK, so that the calibration data can be permanently retained. If the calibration does not end and stops, the calibration data for completed range will be invalid after the power is off.

1. DC voltage calibration (the following steps serve only as reference; the value entered should be in accordance with the prompt on the screen)

Enter the calibration interface of DCV, the default range for calibration is 200mV

200mV: short circuit for the input terminals; after the measured value is stable press Enter to confirm. Then according to the prompt, enter 200mV, then set the true value, after the measured value is stable press Enter to confirm. Then the calibration for 200mV range is completed, and the program will automatically switch to the 2V level, and change the prompt.

2V: short circuit for the input terminals, after the measured value is stable press Enter to confirm. Then according to the prompt, enter 2V, then set the true value, after the measured value is stable press Enter to confirm. Then the calibration for 2V range is completed, and the program will automatically switch to the 20V level, and change the prompt.

20V: short circuit for the input terminals, after the measured value is stable press Enter to confirm. Then according to the prompt, enter 20V, then set the true value, after the measured value is stable press Enter to confirm. Then the calibration for 20V range is completed, and the program will automatically switch to the 200V level, and change the prompt.

200V: short circuit for the input terminals, after the measured value is stable press Enter to confirm. Then according to the prompt, enter 200V, then set the true value, after the measured value is stable press Enter to confirm. Then the calibration for 200V range is completed, and the program will automatically switch to the 1000V level, and change the prompt.

1000V: short circuit for the input terminals, after the measured value is stable press Enter to confirm. Then according to the prompt, enter 1000V, then set the true value, after the measured value is stable press Enter to confirm, and the secondary display shows OK. Then the calibration of DCV is complete, and the program will write the above calibration data into FLASH.

## **2. AC voltage calibration (the following steps serve only as reference; the value entered should be in accordance with the prompt on the screen)**

Enter the calibration interface of ACV, the default range for calibration is 200mV

200mV: According to the prompt, enter the right value, then set the true value, after the measured value is stable press Enter to confirm. Then the calibration for 200mV range is completed, and the program will automatically switch to the 2V level, and change the prompt.

2V: According to the prompt, enter the right value, then set the true value, after the measured value is stable press Enter to confirm. Then the calibration for 200mV range is completed, and the program will automatically switch to the 2V level, and change the prompt.

20V: According to the prompt, enter the right value, then set the true value, after the measured value is stable press Enter to confirm. Then the calibration for 20V range is completed, and the program will automatically switch to the 200V level, and change the prompt.

200V: According to the prompt, enter the right value, then set the true value, after the measured value is stable press Enter to confirm. Then the calibration for 200V range is completed, and the program will automatically switch to the 750V level, and change the prompt.

750V: According to the prompt, enter the right value, then set the true value, after the

measured value is stable press Enter to confirm. Then the calibration for 750V range is completed, and the secondary display shows OK. Then the calibration of ACV is complete, and the program will write the above calibration data into FLASH.

**3. DC current calibration (the following steps serve only as reference; the value entered should be in accordance with the prompt on the screen)**

Enter the calibration interface of DCI, the default range for calibration is 200uA

200uA: open circuit for the input terminals, after the measured value is stable press Enter to confirm. Then according to the prompt, enter 200uA, then set the true value, after the measured value is stable press Enter to confirm. Then the calibration for 200uA range is completed, and the program will automatically switch to the 2mA level, and change the prompt.

2mA: open circuit for the input terminals, after the measured value is stable press Enter to confirm. Then according to the prompt, enter 2mA, then set the true value, after the measured value is stable press Enter to confirm. Then the calibration for 2mA range is completed, and the program will automatically switch to the 20mA level, and change the prompt.

20mA: open circuit for the input terminals, after the measured value is stable press Enter to confirm. Then according to the prompt, enter 20mA, then set the true value, after the measured value is stable press Enter to confirm. Then the calibration for 20mA range is completed, and the program will automatically switch to the 200mA level, and change the prompt.

200mA: open circuit for the input terminals, after the measured value is stable press Enter to confirm. Then according to the prompt, enter 200mA, then set the true value, after the measured value is stable press Enter to confirm. Then the calibration for 200mA range is completed, and the program will automatically switch to the 2A level, and change the prompt.

2A: open circuit for the input terminals, after the measured value is stable press Enter to confirm. Then according to the prompt, enter 2A, then set the true value, after the measured value is stable press Enter to confirm. Then the calibration for 2A range is completed, and the program will automatically switch to the 10A level, and change the



prompt.

10A: open circuit for the input terminals, after the measured value is stable press Enter to confirm. Then according to the prompt, enter 2A, then set the true value, after the measured value is stable press Enter to confirm, and the secondary display shows OK. Then the calibration of DCI is complete, and the program will write the above calibration data into FLASH.

**4. AC current calibration (the following steps serve only as reference; the value entered should be in accordance with the prompt on the screen)**

Enter the calibration interface of ACI, the default range for calibration is 200uA (with the frequency of 1kHz)

200uA: Input 20uA, after the measured value is stable press Enter to confirm. Then according to the prompt, enter 200uA, then set the true value, after the measured value is stable press Enter to confirm. Then the calibration for 200uA range is completed, and the program will automatically switch to the 2mA level, and change the prompt.

2mA: Input 200uA, after the measured value is stable press Enter to confirm. Then according to the prompt, enter 2mA, then set the true value, after the measured value is stable press Enter to confirm. Then the calibration for 2mA range is completed, and the program will automatically switch to the 20mA level, and change the prompt.

20mA: Input 2mA, after the measured value is stable press Enter to confirm. Then according to the prompt, enter 20mA, then set the true value, after the measured value is stable press Enter to confirm. Then the calibration for 20mA range is completed, and the program will automatically switch to the 200mA level, and change the prompt.

200mA: Input 20mA, after the measured value is stable press Enter to confirm. Then according to the prompt, enter 200mA, then set the true value, after the measured value is stable press Enter to confirm. Then the calibration for 200mA range is completed, and the program will automatically switch to the 2A level, and change the prompt.

2A: according to the prompt, enter the proper value, then set the true value, after the

measured value is stable press Enter to confirm. Then the calibration for 2A range is completed, and the program will automatically switch to the 10A level, and change the prompt.

10A: Input 200mA, after the measured value is stable press Enter to confirm. Then according to the prompt, enter 2A, then set the true value, after the measured value is stable press Enter to confirm, and the secondary display shows OK. Then the calibration of ACI is complete, and the program will write the above calibration data into FLASH.

**5. Resistance calibration (2-wire/4-wire all need calibration) (the following steps serve only as reference; the value entered should be in accordance with the prompt on the screen)**

Enter the resistance calibration interface, the default range for calibration is 200Ω

200Ω: short circuit for the input terminals, after the measured value is stable press Enter to confirm. Then according to the prompt, enter 200Ω, then set the true value, after the measured value is stable press Enter to confirm. Then the calibration for 200Ω range is completed, and the program will automatically switch to the 2kΩ level, and change the prompt.

2kΩ: short circuit for the input terminals, after the measured value is stable press Enter to confirm. Then according to the prompt, enter 2kΩ, then set the true value, after the measured value is stable press Enter to confirm. Then the calibration for 2kΩ range is completed, and the program will automatically switch to the 20kΩ level, and change the prompt.

20kΩ: short circuit for the input terminals, after the measured value is stable press Enter to confirm. Then according to the prompt, enter 20kΩ, then set the true value, after the measured value is stable press Enter to confirm. Then the calibration for 20kΩ range is completed, and the program will automatically switch to the 200kΩ level, and change the prompt.

200kΩ: short circuit for the input terminals, after the measured value is stable press Enter to confirm. Then according to the prompt, enter 200kΩ, then set the true value, after the measured value is stable press Enter to confirm. Then the calibration for

200kΩ range is completed, and the program will automatically switch to the 2MΩ level, and change the prompt.

2MΩ: short circuit for the input terminals, after the measured value is stable press Enter to confirm. Then according to the prompt, enter 2MΩ, then set the true value, after the measured value is stable press Enter to confirm. Then the calibration for 2MΩ range is completed, and the program will automatically switch to the 20MΩ level, and change the prompt.

20MΩ: short circuit for the input terminals, after the measured value is stable press Enter to confirm. Then according to the prompt, enter 20MΩ, then set the true value, after the measured value is stable press Enter to confirm, and the secondary display shows OK. Then the resistance calibration is complete, and the program will write the above calibration data into FLASH.

**6. Capacitance calibration (the following steps serve only as reference; the value entered should be in accordance with the prompt on the screen)**

Enter the resistance calibration interface, the default range for calibration is 2nF

2nF: open circuit for the input terminals, after the measured value is stable press Enter to confirm. Then according to the prompt, enter 2nF, then set the true value, after the measured value is stable press Enter to confirm. Then the calibration for 2nF range is completed, and the program will automatically switch to the 20nF level, and change the prompt.

20nF: open circuit for the input terminals, after the measured value is stable press Enter to confirm. Then according to the prompt, enter 20nF, then set the true value, after the measured value is stable press Enter to confirm. Then the calibration for 20nF range is completed, and the program will automatically switch to the 200nF level, and change the prompt.

200nF: open circuit for the input terminals, after the measured value is stable press Enter to confirm. Then according to the prompt, enter 200nF, then set the true value, after the measured value is stable press Enter to confirm. Then the calibration for 200nF range is completed, and the program will automatically switch to the 2μF level, and change the prompt.

2uF: open circuit for the input terminals, after the measured value is stable press Enter to confirm. Then according to the prompt, enter 2uF, then set the true value, after the measured value is stable press Enter to confirm. Then the calibration for 2uF range is completed, and the program will automatically switch to the 20uF level, and change the prompt.

20uF: open circuit for the input terminals, after the measured value is stable press Enter to confirm. Then according to the prompt, enter 20uF, then set the true value, after the measured value is stable press Enter to confirm. Then the calibration for 20uF range is completed, and the program will automatically switch to the 200uF level, and change the prompt.

200uF: open circuit for the input terminals, after the measured value is stable press Enter to confirm. Then according to the prompt, enter 200uF, then set the true value, after the measured value is stable press Enter to confirm. Then the calibration for 200uF range is completed, and the program will automatically switch to the 2mF level, and change the prompt.

2mF: open circuit for the input terminals, after the measured value is stable press Enter to confirm. Then according to the prompt, enter 2mF, then set the true value, after the measured value is stable press Enter to confirm, and the secondary display shows OK. Then the resistance calibration is complete, and the program will write the above calibration data into FLASH.

## 8 Communication interface

MDM8155A is equipped with communication interfaces: RS232 and USB.

MDM8145A / MDM8146A are equipped with communication interface USB, the RS232 communication interface is optional.

### 1. Connection and setting of RS232 interface:

The meter is connected to the computer via a parallel one-male-and-one-female serial port line.

RS232 interface: Baud rate is 115200bits / s, a frame of the information is 9 digits,

8-digit data, 1 stop bit, no parity check.

## 2. USB Device interface

The meter is connected to the computer through a USB port and then a square line

The USB drive for STM32 USB should be installed on the computer to use the USB.

# 9. Installation and use of relevant software

(See the Operating Instructions in the software CD attached)

# 10. Maintenance and upkeep

## 1. General maintenance and repair

1) About one year after the instrument is used, re-calibrate the instrument to ensure that the indicators meet the requirements.

2) When any abnormality is found to the instrument after measuring, conduct self-test first. If the test fails or if the self-test passes but there is still abnormality, immediately stop using and sent it for repair.

3) If the re-calibration or repair of the instrument is needed, send it back to the manufacturer or dealer, and to have it repaired or calibrated by a qualified professional.

## 2. Replace the fuse

Refer to "4.5 Introduction to the back panel" to find where the fuse is, one is the power fuse, and the other current fuse.

Specifications of fuse:

0.5A L 250V fast-blow fuse  $\Phi 5 \times 20 \text{mm}$

Steps:

1) Turn off the power and unplug the power plug.

2) Find the location of the fuse; remove the blown fuse according to the prompts on the instrument.

3) Replace the fuse, and install the new fuse.

