

Advantys STB

System Planning and Installation Guide

8/2009

Schneider Electric assumes no responsibility for any errors that may appear in this document. If you have any suggestions for improvements or amendments or have found errors in this publication, please notify us.

No part of this document may be reproduced in any form or by any means, electronic or mechanical, including photocopying, without express written permission of Schneider Electric.

All pertinent state, regional, and local safety regulations must be observed when installing and using this product. For reasons of safety and to help ensure compliance with documented system data, only the manufacturer should perform repairs to components.

When devices are used for applications with technical safety requirements, the relevant instructions must be followed.

Failure to use Schneider Electric software or approved software with our hardware products may result in injury, harm, or improper operating results.

Failure to observe this information can result in injury or equipment damage.

© 2009 Schneider Electric. All rights reserved.

Table of Contents



	Safety Information	5
	About the Book	7
Chapter 1	Site Requirements for an Advantys STB Island Installation	11
1.1	Introduction to the Advantys STB System	12
	Advantys STB Island Basics	13
	Island Segments	17
1.2	Operating Environment	23
	Operating Environment	24
	STB Module Operating Temperature Ranges	26
	Explosive Environments	35
	Maritime Environment	39
1.3	Initial Planning Considerations	44
	Enclosing the STB Island	45
	The Power Distribution Modules	52
	Logic, Sensor and Actuator Power Distribution on the Island Bus	57
	Power Supply Selection	64
Chapter 2	Advantys STB System Installation Procedures	67
	Installation Quick Start Guide	68
	The Layout of Modules on an Island Bus	71
	The DIN Rail	76
	Installing the NIM in the First Location on the Island	77
	Keying Considerations	83
	Interlocking Base Units on the DIN Rail	94
	Terminating the Last Device on the Island	98
	Installing Advantys STB Modules in their Bases	102
Chapter 3	Extending an Advantys STB Island Bus	107
	Island Bus Extensions	108
	Installing Extension Segments of Advantys STB Island Modules	109
	Installing a Preferred Module Extension	114
	Installing an CANopen Device Extension	118

Chapter 4	Grounding Considerations	121
	Power Isolation Requirements on the Island Bus	122
	Voltage Cut-out Switching	123
	The Protective Earth Connection	124
	The Functional Earth Connection	126
	EMC Kits	127
Chapter 5	Commissioning an Advantys STB Island	137
	Making Fieldbus and Power Connections	138
	Configuring the Island	142
	Changing Baud Rates	145
	Hot Swapping Advantys STB I/O Modules	146
	Fault Detection and Troubleshooting	154
Glossary	159
Index	183

Safety Information

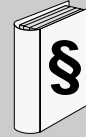

Important Information

NOTICE

Read these instructions carefully, and look at the equipment to become familiar with the device before trying to install, operate, or maintain it. The following special messages may appear throughout this documentation or on the equipment to warn of potential hazards or to call attention to information that clarifies or simplifies a procedure.



The addition of this symbol to a Danger or Warning safety label indicates that an electrical hazard exists, which will result in personal injury if the instructions are not followed.



This is the safety alert symbol. It is used to alert you to potential personal injury hazards. Obey all safety messages that follow this symbol to avoid possible injury or death.

DANGER

DANGER indicates an imminently hazardous situation which, if not avoided, **will result in** death or serious injury.

WARNING

WARNING indicates a potentially hazardous situation which, if not avoided, **can result in** death or serious injury.

 **CAUTION**

CAUTION indicates a potentially hazardous situation which, if not avoided, **can result in** minor or moderate injury.

CAUTION

CAUTION, used without the safety alert symbol, indicates a potentially hazardous situation which, if not avoided, **can result in** equipment damage.

PLEASE NOTE

Electrical equipment should be installed, operated, serviced, and maintained only by qualified personnel. No responsibility is assumed by Schneider Electric for any consequences arising out of the use of this material.

A qualified person is one who has skills and knowledge related to the construction and operation of electrical equipment and the installation, and has received safety training to recognize and avoid the hazards involved.

About the Book

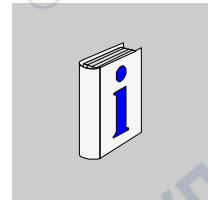

At a Glance

Document Scope

This book provides the information you will need in order to plan and install an Advantys STB island. The installation will comprise some combination of an Advantys STB network interface module, one or more power distribution modules, various I/O modules, and perhaps some island bus extension modules and cables.

Validity Note

This document is valid for Advantys 4.5 or later.

Related Documents

Title of Documentation	Reference Number
Advantys STB Analog I/O Modules Reference Guide	31007715 (E), 31007716 (F), 31007717 (G), 31007718 (S), 31007719 (I)
Advantys STB Digital I/O Modules Reference Guide	31007720 (E), 31007721 (F), 31007722 (G), 31007723 (S), 31007724 (I)
Advantys STB Counter Modules Reference Guide	31007725 (E), 31007726 (F), 31007727 (G), 31007728 (S), 31007729 (I)

Advantys STB Special Modules Reference Guide	31007730 (E), 31007731 (F), 31007732 (G), 31007733 (S), 31007734 (I)
Advantys STB Standard Profibus DP Network Interface Applications Guide	31002957 (E), 31002958 (F), 31002959 (G), 31002960 (S), 31002961 (I)
Advantys STB Basic Profibus DP Network Interface Applications Guide	31005773 (E), 31005774 (F), 31005775 (G), 31005776 (S), 31005777 (I)
Advantys STB Standard INTERBUS Network Interface Applications Guide	31004624 (E), 31004625 (F), 31004626 (G), 31004627 (S), 31004628 (I)
Advantys STB Basic INTERBUS Network Interface Applications Guide	31005789 (E), 31005790 (F), 31005791 (G), 31005792 (S), 31005793 (I)
Advantys STB Standard DeviceNet Network Interface Applications Guide	31003680 (E), 31003681 (F), 31003682 (G), 31003683 (S), 31004619 (I)
Advantys STB Basic DeviceNet Network Interface Applications Guide	31005784 (E), 31005785 (F), 31005786 (G), 31005787 (S), 31005788 (I)
Advantys STB Standard CANopen Network Interface Applications Guide	31003684 (E), 31003685 (F), 31003686 (G), 31003687 (S), 31004621 (I)

Advantys STB Basic CANopen Network Interface Applications Guide	31005779 (E), 31005780 (F), 31005781 (G), 31005782 (S), 31005783 (I)
Advantys STB Standard Ethernet Modbus TCP/IP Network Interface Applications Guide	31003688 (E), 31003689 (F), 31003690 (G), 31003691 (S), 31004622 (I)
Advantys STB Standard EtherNet/IP Network Interface Applications Guide	31008024 (E), 31008025 (F), 31008026 (G), 31008027 (S), 31008028 (I)
Advantys STB Standard Modbus Plus Network Interface Applications	31004629 (E), 31004630 (F), 31004631 (G), 31004632 (S), 31004633 (I)
Advantys STB Standard Fipio Network Interface Applications Guide	31003692 (E), 31003693 (F), 31003694 (G), 31003695 (S), 31004623 (I)
Advantys STB Configuration Software Quick Start User Guide	31002962 (E), 31002963 (F), 31002964 (G), 31002965 (S), 31002966 (I)
Advantys STB Reflex Actions Reference Guide	31004635 (E), 31004636 (F), 31004637 (G), 31004638 (S), 31004639 (I)

You can download these technical publications and other technical information from our website at www.schneider-electric.com.

User Comments

We welcome your comments about this document. You can reach us by e-mail at techcomm@schneider-electric.com.

Site Requirements for an Advantys STB Island Installation

1

Overview

This chapter describes the external requirements that need to be considered when you select and plan your Advantys STB installation. In addition, it provides a brief description of what an STB island consists of and includes coverage that lists the operating temperature ranges of all the modules and indicates which ones are certified to operate in hazardous locations and maritime environments.

What's in this Chapter?

This chapter contains the following sections:

Section	Topic	Page
1.1	Introduction to the Advantys STB System	12
1.2	Operating Environment	23
1.3	Initial Planning Considerations	44

1.1 Introduction to the Advantys STB System

Introduction

This section provides a brief overview of what an Advantys STB island consist of. It is intended for anyone who will be involved with the planning and installation of an STB system, but is not familiar with the STB product line and the makeup of an STB island.

What's in this Section?

This section contains the following topics:

Topic	Page
Advantys STB Island Basics	13
Island Segments	17

Advantys STB Island Basics

System Definition

Advantys STB is an open, modular distributed I/O system consisting of I/O modules, Power Distribution Module/s (PDM) and a single Network Interface Module (NIM), residing together on a backplane and referred to as an *island*. The island functions as a node on a fieldbus network and communicates with the fieldbus master controller.

The following figure provides a physical representation of an STB island appearing as a node on a typical fieldbus network:

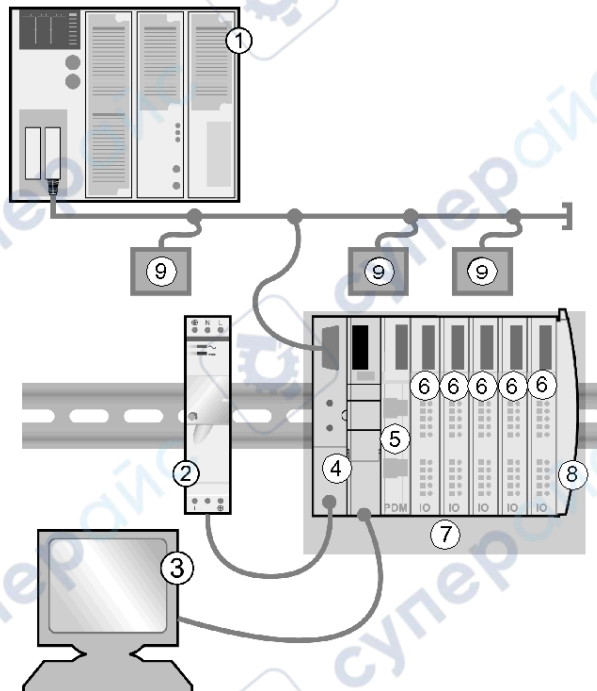

- 1 fieldbus master
- 2 external 24 VDC power supply, the source for logic power on the island
- 3 external device connecting to the CFG port—a computer running the Advantys configuration software or an HMI panel
- 4 NIM
- 5 power distribution module (PDM)
- 6 I/O modules
- 7 STB island node
- 8 island bus terminator plate
- 9 other nodes on the fieldbus network

The physical makeup of the island is called a segment.

Open Fieldbus Choices

An STB island can function on any of the following industry-standard open fieldbus networks:

- Profibus DP
- DeviceNet
- Ethernet
- CANopen
- Fipio
- Modbus Plus
- INTERBUS

The NIM

A NIM resides in the first position on the island (leftmost on the physical setup). The NIM provides the interface between the I/O modules and the fieldbus master. It is the only module on the island that is fieldbus-dependent—a different NIM is available for each fieldbus.

The rest of the I/Os and PDMs on the island function exactly the same, regardless of the fieldbus on which the island resides. You have the advantage of being able to select I/O modules and establish island functionally independent of the fieldbus on which it will operate

Standard Advantys STB Modules

The core set of standard Advantys STB modules comprises:

- a set of analog, digital and special I/O modules
- open fieldbus NIMs
- power distribution modules (PDMs)
- island bus extension modules
- special modules

These standard modules are designed to specific Advantys STB form factors and fit on base units on the island bus. They take full advantage of the island's communication and power distribution capabilities, and they are auto-addressable.

Preferred Modules

You can also use preferred modules in the makeup of the island node. A *preferred module* is a device from another Schneider product line, or potentially from a third-party developer, that fully complies with the Advantys STB island bus protocol. Preferred modules are developed and qualified under agreement with Schneider; they conform fully to Advantys STB standards and are auto-addressable.

For the most part, the island bus handles a preferred module as it does standard Advantys STB I/O module, with four key differences:

- A preferred module is not designed in the standard form factor of an Advantys STB module and does not fit into one of the standard base units. It therefore does not reside in an Advantys STB segment (*see page 17*).
- A preferred module requires its own power supply. It does not get logic power from the island bus.
- To place preferred modules in you island, you must use the Advantys configuration software.
- You cannot use preferred modules with a basic NIM (see below).

Preferred modules can be placed between segments of STB I/O or at the end of the island (*see page 115*). If a preferred module is the last module on the island bus, it must be terminated with a 120 Ω terminator resistor.

Standard CANopen Devices

An Advantys STB island can also support standard off-the-shelf CANopen devices. These devices are not auto-addressable on the island bus, and therefore they must be manually addressed, usually with physical switches built into the devices. They are configured using the Advantys configuration software. You cannot use a standard CANopen device with a basic NIM (see below).

When standard CANopen devices are used, they must be installed at the end of the island. 120 Ω termination must be provided both at the end of the last Advantys STB segment and at the last standard CANopen device.

NIM Types

Your island's performance is determined by the type of NIM that you use. You can choose from two types of NIMs:

- Standard Nim
- Basic Nim

Standard NIMs support all the STB I/O modules as well as preferred modules and standard CANopen devices. They can support up to 32 I/O modules in multiple (extension) segments.

Basic NIMs can only support Advantys STB I/O modules and are limited to 12 I/O modules in a single segment.

Mechatronics

One of the key reasons for selecting Advantys STB is so that you can design a system where the control electronics in the I/O modules reside as close as possible to the mechanical devices they are controlling. This concept is known as *mechatronics*.

Island Length

With any Advantys STB standard NIM, you may extend an island bus to multiple segments of I/O. Using bus extension cables and modules, an island bus with a standard NIM can be stretched to distances up to 15 m (49.21 ft).

Island Segments

The Primary Segment

Every Advantys STB island bus begins with a group of interconnected devices called the *primary segment*. It is a mandatory piece of an island. The primary segment consists of the island's NIM and a set of interconnected module bases attached to a DIN rail. The PDMs and Advantys STB I/O module mount in these bases on the DIN rail. The NIM is always the first (leftmost) module in the primary segment.

Depending on your needs, the island may optionally be expanded to additional segments of Advantys STB modules, called *extension segments*.

The DIN Rail

The NIM and the module bases snap onto a 35 mm wide, conductive metal, DIN rail, shown below.



The Bases

The STB bases provide the physical connections for the I/O modules on the island bus. These connections let you communicate with the NIM over the island bus. A set of contacts on the side of the bases enable the modules to receive:

- logic power from the NIM or from a beginning of segment BOS module
- sensor power (for inputs) or actuator power (for outputs) from the PDM
- actuator power to the output modules
- the auto-addressing signal
- island bus communications between the I/O and the NIM

There are seven types of bases (*see page 95*) that can be used in a segment. Specific bases must be used with specific module types, and it is important that you always install the correct bases in the appropriate locations in each segment.

The following illustration shows some of the key components of an STB XBA 1000 base:

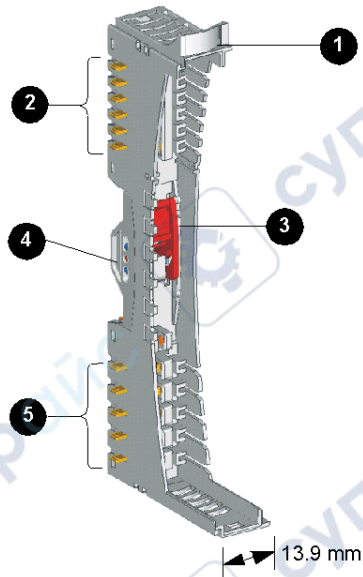

- 1 user-customizable label tab
- 2 six island bus contacts
- 3 DIN rail lock/release latch
- 4 DIN rail contact
- 5 five field power distribution contacts

As you plan and assemble the island bus, make sure that you choose and insert the correct base in each location on the island bus.

The Island Bus

The module bases that you interconnect on the DIN rail form an island bus structure. The island bus houses the modules and supports the communications buses across the island.

The NIM, unlike the PDMs and I/O modules, attaches directly to the DIN rail.

When an STB system consists of a single primary segment, the island must be terminated with a terminator plate in the last right-hand position of the island. If a second segment were to be added, the terminator plate would have to be replaced with an End of Segment (EOS) extension module.

The makeup of an island bus is illustrated below.

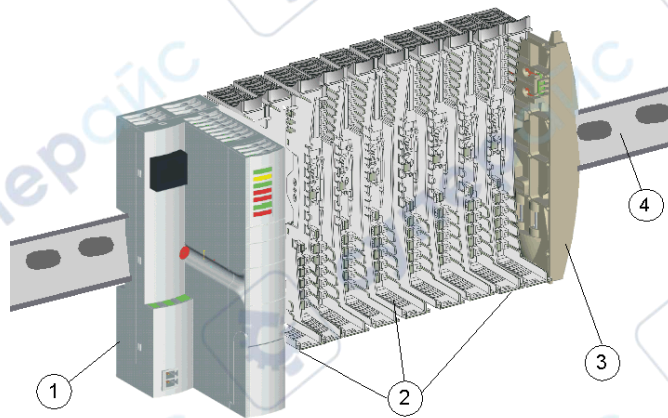

- 1 NIM
- 2 module bases
- 3 termination plate
- 4 DIN rail

An Example of an STB Island

The illustration below shows the island bus filled in with standard Advantys STB modules, including a NIM, two PDMs, and six AC and DC I/O modules that make up a primary island segment.

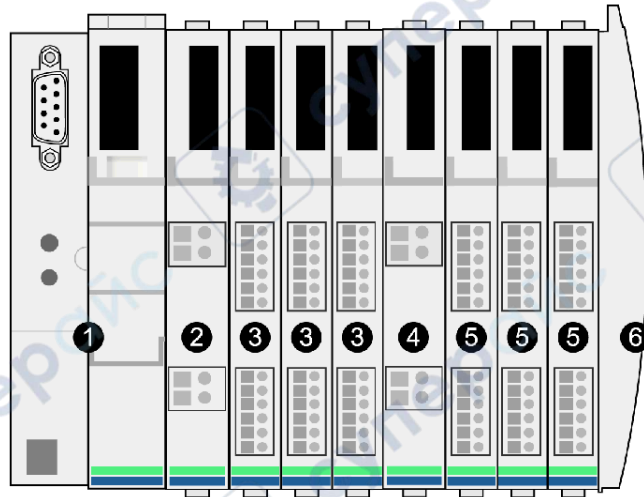

- 1 The NIM in the first location of the segment.
- 2 A 115/230 VAC STB PDT 2100 PDM, installed directly to the right of the NIM. This module distributes AC power over two separate field power buses, (a sensor bus and an actuator bus) to the three I/O modules directly to its right.
- 3 A voltage group of three digital AC I/O modules installed to the right of the STB PDT 2100 PDM. The input modules in this group receive AC field power from the island's sensor bus, and the output modules in this group receive AC field power from the island's actuator bus.
- 4 A 24 VDC STB PDT 3100 PDM, which distributes 24 VDC across the island's sensor and actuator buses to the three DC I/O modules to its right. This PDM also isolates the AC voltage group to its left from the DC voltage group to its right.
- 5 A voltage group of three digital DC I/O modules installed directly to the right of the STB PDT 3100 PDM. These modules receive 24 VDC field power from the island's sensor and actuator buses.
- 6 An STB XMP 1100 terminator plate (with a 120 Ω terminator resistor).

NOTE: For better immunity in noisy environments, in the event a segment consists of groups of AC and DC I/O modules, you should place the AC group before the DC group (from left to right). You should allow maximum distance between analog modules and the AC modules, the relay modules, or the CPS 2111. For example, place the analog modules at the end of the DC group.

The NIM's Functions

The first module on the primary segment is a NIM that performs several key functions:

- It is the master of the island bus, supporting the I/O modules by acting as their communications interface across the bus.
- It is the gateway between the island and the fieldbus on which the island operates, managing data exchange between the island's I/O modules and the fieldbus master.
- It may be the interface to the Advantys configuration software; basic NIMs do not provide a software interface.
- It is the primary power source for logic power on the island bus, delivering a 5 VDC logic power to the I/O modules in the primary segment.

Different NIM models (*see page 29*) are available to support the various open fieldbuses and different operational requirements. Choose the NIM that meets your needs and operates on the appropriate fieldbus protocol. Each NIM is documented in its own user manual.

PDMs

The second module on the primary segment is a PDM (*see page 52*). PDMs are available in different models (*see page 30*) to distribute:

- 24 VDC field power to the I/O modules in a segment
- 115 VAC or 230 VAC field power to the I/O modules in a segment

The number of different I/O voltage groups that are installed on the segment determine the number of PDMs that need to be installed. If your segment contains I/O from all three voltage groups, you will need to install at least three separate PDMs in the segment.

Different PDM models are available with scalable performance characteristics.

I/O Modules

The example shown above contains both digital AC and DC I/O modules that provide 115/230 VAC and 24 VDC power to the island's sensor and actuator busses. The selection of I/O modules that makeup an STB island is determined by the input and output requirements of the external devices they will be controlling. The Advantys STB product line provides a wide selection of analog and digital I/O modules to satisfy those requirements.

I/O Module Logic Power

Logic power is the power that the STB I/O modules require to run their internal processing and light their LEDs.

The NIM converts the incoming 24 VDC to 5 VDC. The NIM then distributes the 5 VDC as logic power for the primary segment (*see page 57*). A similar power supply built into the BOS modules provides 5 VDC for the I/O modules in any extension segments.

Each of these supplies produce 1.2 A, and the sum of the logic power current consumed by all the I/O modules in a segment cannot exceed that value. Therefore, the maximum number of modules allowed in a segment is determined by their total current draw (*see page 32*) which is limited to 1.2 A with a maximum operating temperature of 60°C.

The Last Device on the Primary Segment

If the STB island consists of only a single (primary) segment, the island bus must be terminated with a 120 Ω terminator resistor. Use an STB XMP 1100 terminator plate, which contains this resistor, at the end of the segment.

Extending the Island Bus

If the island bus is extended to another segment of Advantys STB modules or to a preferred module, the terminator plate is replaced by an STB XBE 1100 EOS bus extension module. The EOS module has an IEEE 1394-style output connector for a bus extension cable. The extension cable carries the island's communications bus and auto-addressing line to the extension segment or to the preferred module. Island bus extensions (*see page 107*) are discussed further in this book.

Remember that you cannot use extensions when a basic NIM is in the primary segment.

CANopen Extension Module

If the island bus is extended to a standard CANopen device, you need to install an STB XBE 2100 CANopen extension module to the left of the STB XMP 1100 terminator plate.

1.2 Operating Environment

Introduction

This section describes the environment considerations that apply to the Advantys STB modules; in particular, the temperature ranges that they are qualified to operate within and the logic bus current that each modules draws when operating within those ranges. Also, listings are provided that indicate which modules can be used in hazardous (explosive) and maritime environments.

What's in this Section?

This section contains the following topics:

Topic	Page
Operating Environment	24
STB Module Operating Temperature Ranges	26
Explosive Environments	35
Maritime Environment	39

Operating Environment

Environmental Specifications

The following information describes systemwide environmental requirements and specifications for the Advantys STB system.

Enclosure

This equipment is considered Group 1, Class A industrial equipment according to IEC/CISPR Publication 11. Without appropriate precautions, there may be potential difficulties ensuring electromagnetic compatibility in other environments due to conducted and/or radiated disturbance.

All Advantys STB modules meet CE mark requirements for *open equipment* as defined by EN61131-2, and should be installed in an enclosure that is designed for specific environmental conditions and designed to prevent personal injury resulting from access to live parts. The interior of the enclosure must be accessible only by the use of a tool.

NOTE: Special requirements apply for enclosures located in hazardous (explosive) environments (*see page 35*).

Requirements

This equipment meets agency certification for UL, CSA, CE, FM class 1 div 2 and ATEX. This equipment is intended for use in a Pollution Degree 2 industrial environment, in over-voltage Category II applications (as defined in IEC publication 60664-1), at altitudes up to 2000 m (6500 ft) without derating.

Parameter	Specification	
protection	ref. EN61131-2	IP20, class 1
agency	ref. EN61131-2	UL 508, CSA 1010-1, FM Class 1 Div. 2, CE, ATEX and Maritime
isolation voltage	ref. EN61131-2	1500 VDC field-to-bus for 24 VDC
		2500 VDC field-to-bus for 115/230 VAC
	Note: No internal isolation voltage; isolation requirements must be met by using SELV-based external power supply.	
over-voltage class	ref. EN61131-2	category II
operating temperature range	0 ... 60° C (32 ... 140° F)	
extended operating temperature ranges	-25 ... 0° C (-13 ... 32° F) and 60 ... 70° C (140 ... 158° F) for qualified modules (<i>see page 26</i>)	
storage temperature	-40 ... +85° C (-40 ... +185° F)	
maximum humidity	95% relative humidity @ 60° C (noncondensing)	

Parameter	Specification	
supply voltage variation, interruption, shut-down and start-up	IEC 61000-4-11 ref. 61131-2	
shock	ref. IEC68, part 2-27	+/-15 g peak, 11 ms, half-sine wave for 3 shocks/axis
operating altitude	2000 m (2187 yd)	
transport altitude	3000 m (3281 yd)	
free-fall	ref. EN61131-2	1 m (1.09 yd)
agency certifications	ATEX @ 0 to 60° C and FM @ extended temperature ranges for specified modules (see page 37)	

Electromagnetic Susceptibility

The following table lists the electromagnetic susceptibility specifications:

Characteristic	Specification
electrostatic discharge	ref. EN61000-4-2
radiated	ref. EN61000-4-3
fast transients	ref. EN61000-4-4
surge withstand (transients)	ref. EN61000-4-5
conducted RF	ref. EN61000-4-6

Radiated Emission

The following table lists the emission specification ranges:

Description	Specification	Range
radiated emission	ref. EN 55011 Class A	30 ... 230 MHz, 10 m @ 40 dB μ V
		230 ... 1000 MHz, 10 m @ 47 dB μ V

STB Module Operating Temperature Ranges

Overview

The operating temperature ranges for all the Advantys STB modules are listed in the following tables. All of these products will operate continuously, at full efficiency, in an environment where the ambient temperature is between 0 and 60° C (32 to 140° F). In addition, many of the modules are qualified to operate at extended temperature ranges of -25 to 0° C (-13 to 32° F) and 60 to 70° C (140 to 158° F). Specific limitations may apply to certain modules that operate at the extended temperature ranges. Whenever this is the case, the limitations are described by notes that accompany each affected module.

Input Voltage Power Supply Limitations

The input voltage to the NIM's, STB XBE 1300, STB XBE 1100, STB CPS 2111, STB PDT 3100 modules, and any external (customer supplied) power supply has limitations for the different operating temperature ranges as follows:

- for the -25 to 0° C range, the supply voltage range is 20.4 to 30 VDC
- for the 0 to 60° C range, the supply voltage range is 19.2 to 30 VDC
- for the 60 to 70° C range, the supply voltage range is 19.2 to 26.5, VDC

Analog I/O Modules

The operating temperature ranges for the STB Analog I/O modules are listed below. In the following tables, *No* signifies that the module is not qualified for operation over the indicated temperature range.

Analog Input Modules				
Model	Type	Logic Bus Current Consumption @ Operating Temperature Ranges		
		-25 to 0° C	0 to 60° C	60 to 70° C
STB ACI 0320	Cur, 4 ch, 4-20 mA, 16 bit standard	95 mA	95 mA	95 mA
STB ACI 1230	Cur, 2 ch, 0-20 mA, 12 bit standard	30 mA	30 mA	30 mA
STB ACI 1225	Cur, 2 ch, 4-20 mA, 10 bit basic	No	30 mA	No
STB ACI 1400	Cur, 8 ch, 4-20 mA, 16 bit single ended standard	90 mA	90 mA	90 mA
STB ACI 8320	Cur, 4 ch, 4-20 mA, 16 bit standard	95 mA	95 mA	95 mA
STB ART 0200	RTD/Tc/mV, 2 ch, 15 bit +sign standard	No	30 mA	30 mA
STB AVI 0300	Volt, 4 ch wide range, 16 bit standard	90 mA	90 mA	90 mA
STB AVI 1270	Volt, 2 ch, +/- 10V, 11bit + sign standard	No	30 mA	No
STB AVI 1275	Volt, 2 ch, +/- 10V, 9bit + sign basic	No	30 mA	No

Analog Input Modules				
Model	Type	Logic Bus Current Consumption @ Operating Temperature Ranges		
		-25 to 0° C	0 to 60° C	60 to 70° C
STB AVI 1255	Volt, 2 ch, 0 -10V, 10 bit basic	No	30 mA	No
STB AVI 1400	Volt, 8 ch, wide range, 16 bit single ended standard	90 mA	90 mA	90 mA

Analog Output Modules				
Model	Type	Logic Bus Current Consumption @ Operating Temperature Ranges		
		-25 to 0° C	0 to 60° C	60 to 70° C
STB ACO 0120	Cur, 1 ch, 4-20 mA, 16 bit standard	155 mA	155 mA	155 mA
STB ACO 0220	Cur, 2 ch, 4-20 mA, 16 bit standard	210 mA	210 mA	210 mA
STB ACO 1210	Cur, 2 ch, 0-20 mA, 12 bit standard	No	40 mA	No
STB ACO 1225	Cur, 2 ch, 4-20 mA, 10 bit basic	No	40 mA	No
STB AVO 0200	Volt, 2 ch, wide range, 16 bit standard	265 mA	265 mA	265 mA
STB AVO 1250	Volt, 2 ch, -/+ 10V, 11 bit + sign standard	No	45 mA	No
STBAVO 1255	Volt, 2 ch, 0 +/-10V, 10 bit basic	No	45 mA	No
STB AVO 1265	Volt, 2 ch, -/+ 10V, 9 bit + sign basic	No	45 mA	No

Digital I/O Modules

The operating temperature ranges for the STB Digital I/O modules are listed below. In the following tables, *No* signifies that the module is not qualified for operation over the indicated temperature range.

Digital Input Modules				
Model	Type	Logic Bus Current Consumption @ Operating Temperature Ranges		
		-25 to 0° C	0 to 60° C	60 to 70° C
STB DAI 5230	115VAC, 2pt, 3 wire standard	No	40 mA	No
STB DAI 5260	115 VAC isolated, standard	No	45 mA	No
STB DAI 7220	250 VAC, 2pt, 3 wire, standard	No	40 mA	No
STB DDI 3230	24V DC, 2pt sink, 4 wire standard	55 mA	55 mA	55 mA
STB DDI 3420	24 VDC, 2pt sink, 3 wire standard	45 mA	45 mA	45 mA
STBDDI 3425	24 VDC, 4pt sink, 3 wire basic	No	45 mA	No
STB DDI 3610	24 VDC, 6pt sink, 2 wire standard	55 mA	55 mA	55 mA

Digital Input Modules				
Model	Type	Logic Bus Current Consumption @ Operating Temperature Ranges		
		-25 to 0° C	0 to 60° C	60 to 70° C
STB DDI 3615	24 VDC, 6pt sink, 2 wire basic	No	45 mA	No
STB DDI 3725	24 VDC, 16pt sink, 2 wire basic	100 mA	100 mA	100 mA

Digital Output Modules				
Model	Type	Logic Bus Current Consumption @ Operating Temperature Ranges		
		-25 to 0° C	0 to 60° C	60 to 70° C
STB DAO 5260	115 VAC, isolated, standard	No	70 mA	No
STB DAO 8210	115/230 VAC, 2pt source, 2.0A standard	No	45 mA	No
STB DDO 3200	24 VDC, 2pt source, 0.5A standard	50 mA	50 mA	50 mA
STB DDO 3230	24 VDC, 2pt source, 0.2A standard	45 mA	45 mA	45 mA
STB DDO 3410	24VDC, 4pt source, 0.5A standard	70 mA	70 mA	70 mA
STB DDO 3415	24VDC, 4pt source, 0.25A basic	No	70 mA	No
STB DDO 3600	24VDC, 6pt source, 0.5A standard	90 mA	90 mA	90 mA
STB DDO 3605	24VDC, 6pt source, 0.25A basic	No	90 mA	No
STB DDO 3705	24 VDC, 16pt source, 0.5A basic	135 mA	135 mA	135 mA
STB DRC 3210	Relay, 2pt, 2.0A standard	55 mA	55 mA	55 mA, see Note 1
STB DRA 3290	Relay, 2pt, 7.0A standard	55 mA	55 mA	55 mA, see Note 2

Note 1: For operation between 60 and 70° C, only one relay output point may be used. The relay output point is rated at a maximum load of 2 A. The relay module resides in the DC power group. The STB PDT 3100 is restricted to operate from 19.2 to 24.5 V in the 60 to 70° C temperature range.

Note 2: For operation between 60 and 70° C, only one relay output point may be used. The relay output point is rated at a maximum load of 4 A. The relay module resides in the DC power group. The STB PDT 3100 is restricted to operate from 19.2 to 24.5 V in the 60 to 70° C temperature range.

Special Purpose Modules

The operating temperature ranges for the STB Special Purpose Modules are listed below.

In the following tables, *No* signifies that the module is not qualified for operation over the indicated temperature range.

Special Purpose Modules				
Model	Type	Logic Bus Current Consumption @ Operating Temperature Ranges		
		-25 to 0° C	0 to 60° C	60 to 70° C
STB EHC 3020	High Speed Counter Multimode 40 kHz	100 mA	100 mA	100 mA
STB EPI 1145	Tego Power 16 in/8 out parallel interface	No	115 mA	No
STB EPI 2145	Tesys Type U 12 in/8 out parallel interface	110 mA	110 mA	110 mA
STB XBE 1000	EOS Extension Module	No	25 mA	No
STB XBE 1100	EOS Extension Module	25 mA	25 mA	25 mA
STB XBE 2100	CANopen Extension Module	No	1 mA	No

NIM, BOS & Auxiliary Power Supply Modules

The operating temperature ranges for the STB NIM, BOS and Auxiliary Power Supply modules are listed below.

In the following tables, *No* signifies that the module is not qualified for operation over the indicated temperature range.

NIM, BOS, and Auxiliary Power Supply Modules					
Model	*Product Version	Type	Logic Bus Current Supply @ Operating Temperature Ranges		
			-25 to 0° C	0 to 60° C	60 to 70° C
STB NCO 1010	N/A	CANopen NIM basic	No	1.2 A	No
STB NCO 2212	12	CANopen NIM standard	**1.2 A	1.2 A	575 mA
STB NDN 1010	N/A	DeviceNet NIM basic	No	1.2 A	No
STB NDN 2212	12	DeviceNet NIM standard	**1.2 A	1.2 A	575 mA
STB NDP 1010	N/A	Profibus DP NIM basic	No	1.2 A	No
STB NDP 2212	14	Profibus DP NIM standard	**1.2 A	1.2 A	575 mA
STB NFP 2212	17	FIPIO NIM standard	**1.2 A	1.2 A	575 mA
STB NIB 1010	N/A	INTERBUS NIM basic	No	1.2 A	No
STB NIB 2212	13	INTERBUS NIM standard	**1.2 A	1.2 A	575 mA
STB NIC 2212	N/A	EtherNet/IP NIM standard	**1.2 A	1.2 A	900 mA
STB NIP 2212	10	Ethernet MB TCP/IP NIM standard	**1.2 A	1.2 A	575 mA
STB NIP 2311		Dual Port Ethernet MB TCP/IP NIM standard			
STB NMP 2212	14	Modbus Plus NIM standard	**1.2 A	1.2 A	575 mA
STB CPS 2111	N/A	Auxiliary Power Supply	1.2 A	1.2 A	900 mA

NIM, BOS, and Auxiliary Power Supply Modules					
Model	*Product Version	Type	Logic Bus Current Supply @ Operating Temperature Ranges		
			-25 to 0° C	0 to 60° C	60 to 70° C
STB XBE 1200	N/A	BOS Extension Module	No	1.2 A	No
STB XBE 1300	N/A	BOS Extension Module	1.2 A	1.2 A	900 mA

*The NIM must be at the product version (PV) indicated, or higher, to operate at the extended temperature range of 60 to 70° C.
 **The NIM must be at product version (PV) 9.9, or higher, to operate in the -25 to 0° C extended temperature range.

Location of the NIM’s Product Version Marking

The product version (PV) is indicated in the markings that appear on the upper left-hand side of each NIM:

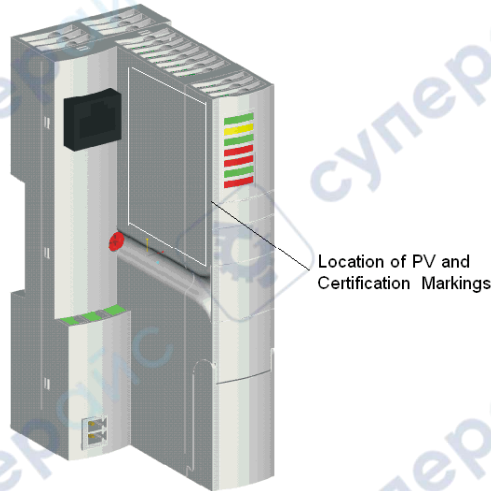

Power Distribution Modules

The operating temperature ranges for the power distribution modules are listed below.

In the following tables, *No* signifies that the module is not qualified for operation over the indicated temperature range.

PDMs				
Model	Type	Field Power Supplied to I/O Modules @ Operating Temperature Ranges		
		-25 to 0° C	0 to 60° C	60 to 70° C
STB PDT 2100	120/230 VAC Power Distr. standard	No	Sensor 2.5 A @ 60° C & 5 A @ 30° C Actuator 5 A @ 60° C & 10 A @ 30° C	No
STB PDT 2105	120/230 VAC Power Distr. basic	No	4 A	No
STB PDT 3100	24 VDC Power Distr. standard	12 A	8.0 A (see curve below)	6.0 A (see curve below)
STB PDT 3105	24 VDC Power Distr. basic	No	4 A	No

STB PDT 3100 Performance Considerations

For the STB PDT 3100 PDM, the maximum combined module current—the sum of the actuator and sensor currents—depends upon the island's ambient temperature. The following diagram presents a curve that plots the modules's maximum combined current against it's operating temperature range.

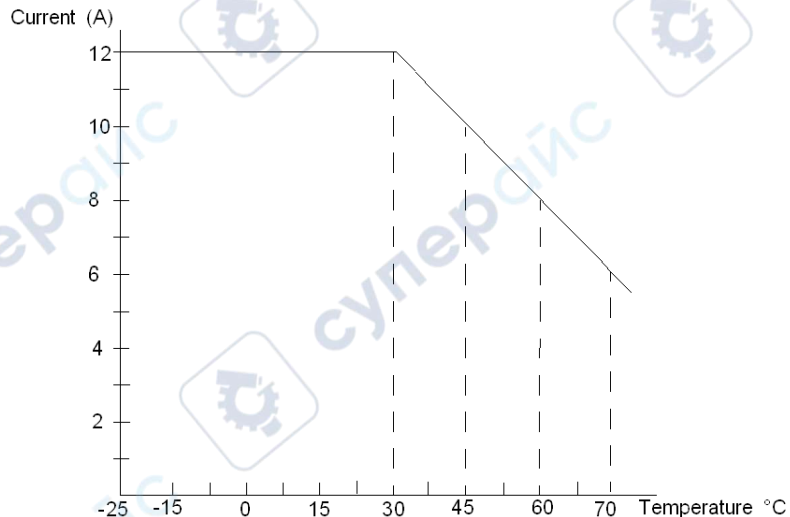

This example shows:

- At 70 °C the total maximum combined current is 6 A
- At 60 °C the total maximum combined current is 8 A

- At 45 °C the total maximum combined current is 10 A
- At 30 °C the total maximum combined current is 12 A

NOTE: At any temperature, the maximum actuator current is 8 A (6 A at 70 °C) and the maximum sensor current is 4 A.

Logic Bus Current Draw Limitations

The total bus current drawn from the NIM's power supply is determined by the number of I/O modules that are placed in the STB island segment. The more modules, the greater the amount of current required to support them. You can determine the total bus current required from the NIM by totaling the individual current requirements for all the I/O modules residing on the island.

The total bus current value must fall within the allowable current draw limit listed for the particular type of NIM module existing on the island. If the logic bus current draw exceeds the capacity of the NIM, then the island segment needs to be divided into smaller segments, or an auxiliary power supply needs to be added to the segment.

The Current Draw Example (below) illustrates this situation.

Two bus current values are listed in the NIMs temperature table: one for the 0 to 60° C operating temperature range (1.2 A) and another for the 60 to 70° C range (575 mA). Make sure you consult the correct NIM operating temperature range for your application.

NOTE: Only standard NIM modules qualify for the extended temperature range of -25 to 70° C.

Current Draw Example

Consider an STB island consisting of a NIP 2212 NIM, a PDT 3100 PDM, and seven I/O modules:

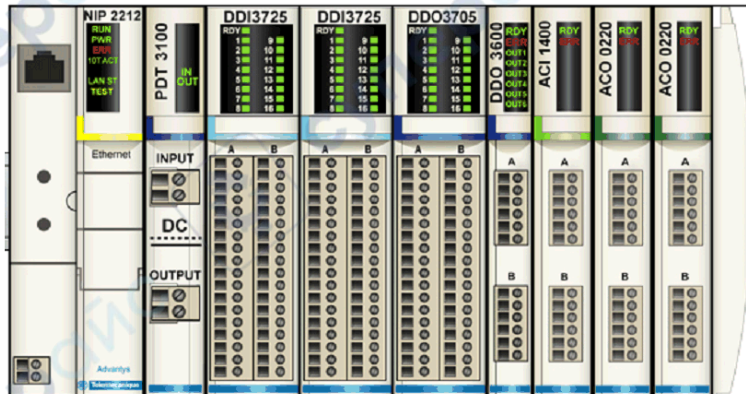

Do the following in order to determine the total bus current draw from the NIM's power supply:

1. Refer to the operating temperature range table (*see page 26*) for the I/O modules.
2. Jot down the bus current listed for each module at both the normal (0 to 60° C) and the extended (60 to 70° C) temperature ranges.
3. Add up the current values to arrive at the total current draw for the modules for both temperature ranges.

The result of this process is shown in the following table.

Module	Description	I/O Logic Current Draw @	
		0 to 60° C	60 to 70° C
STB DDI 3725	24 VDC IN 16pt sink 2 wire basic	100 mA	100 mA
STB DDI 3725	24 VDC IN 16pt sink 2 wire basic	100 mA	100 mA
STB DDO 3705	24 VDC OUT 16pt source 0.5A basic	135 mA	135 mA
STB DDO 3600	24 VDC OUT 6pt source 0.5A standard	90 mA	90 mA
STB ACI 1400	Cur 8ch 4-20 mA 16 bit single-ended	90 mA	90 mA
STB ACO 0220	Cur 2ch 4-20 mA 16 bit standard	210 mA	210 mA
STB ACO 0220	Cur 2ch 4-20 mA 16 bit standard	210 mA	210 mA
Total current draw on the NIM power supply		935 mA	935 mA

Next:

1. Look up the logic bus current supply value for the NIP 2212 NIM in the NIM's operating temperature range table (*see page 29*).
2. Compare the NIM bus current supply value (step 1) with the total I/O current draw value in the table.

For this example, the NIMs operating temperature range table shows that the NIP 2212 NIM can supply 1.2 A over the 0 to 60° C temperature range but only 575 mA over the 60 to 70° C range. Comparing these figures with the total I/O module current draw calculated for the island (in table above) shows that:

- For the 0 to 60° C temperature range, the total 935 mA I/O current draw is well within the NIM's power supply limit of 1.2 A.
- For the 60 to 70° C temperature range, the total 935 mA I/O current draw is 360 mA above the NIM's 575 mA limit.

From this comparison we can draw the following conclusions:

- Under the normal 0 to 60° C temperature range, the NIM's power supply is fully capable of providing the required I/O modules current draw.
- Under the extended 60 to 70° C temperature range, the NIM's power supply falls short of providing the required I/O modules current draw and must be supplemented by an additional supply.

So, to provide the additional 360 mA required for the extended temperature range, an STB CPS 2111 auxiliary power supply needs to be added to the island's configuration as shown in the following figure.

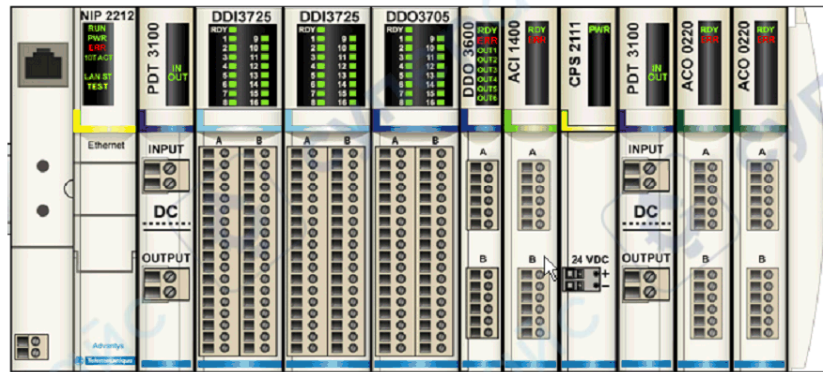

Explosive Environments

Overview

Many of the Advantys STB modules are certified for use in hazardous locations where potentially explosive atmospheres may exist. An explosive atmosphere occurs when air mixes with flammable substances in the form of gases, vapors, mists or dust in which ignition can occur and combustion then spreads throughout the entire unburned mixture resulting in an explosion. This section discusses the requirements that must be met in order to install an STB island in an explosive environment and lists the ATEX and NEC (National Electric Code, NFPA 70) certification ratings for each STB module.

Planning Guidelines

DANGER

EXPLOSION HAZARD

Do not substitute components, which may impair suitability for Ex or Class 1 Division 2 environments.

Failure to follow these instructions will result in death or serious injury.

DANGER

EXPLOSION HAZARD

Do not separate, assemble, or disconnect/connect equipment unless power has been switched off or the area is known to be non-hazardous.

Failure to follow these instructions will result in death or serious injury.

DANGER

EXPLOSION HAZARD

Do not open fuse door unless power has been switched off or the area is known to be non-hazardous.

Failure to follow these instructions will result in death or serious injury.

When planning the installation of an STB island that will be located within an explosive environment you must meet the following requirements:

- Install the equipment within a tool-secured, IP 54 enclosure that is capable of accepting Zone 2 wiring methods and meets the applicable requirements of EN 60079-0 and EN 60079-15.
- The location of the installation must fall within the guidelines for hazardous environments spelled out in ATEX Directive 94/9/EC, and NEC Class 1, Div. 2 (see Certifications, below).

Certifications

Schneider Electric's Advantys STB series of modules that are certified for use in an explosive environment are listed in the table below. The modules are ATEX certified for the European market and FM approved for the North American market. The certification ratings that appear in the table are described below.

The NEC uses a Class/Division/Group rating system defined by the National Fire Protection Association. The STB modules are Factory Mutual (FM) certified in accordance with the NEC ratings as follows:

- Class I - Area where ignitable concentrations of flammable gases or liquid vapors are present.
- Division 2 - Hazardous substances are present only during abnormal conditions (such as a leak).
- Group A - Acetylene (Most Volatile)
- Group B - Hydrogen
- Group C - Ethylene
- Group D - Methane
- T4 represents a temperature code of the hottest surface that can be in contact with a gas.

The ATEX directive uses Equipment Groups which are subdivided into Equipment Categories. The STB modules are ATEX certified by Factory Mutual as follows:

- Equipment Group II - Equipment intended for non-mining applications, but used in places likely to become endangered by explosive atmospheres.
- Equipment Category 3 - Equipment for use in areas which an explosive atmosphere is unlikely to occur, or only infrequently, or for short periods of time.
- G = Gas environment
- IIC = Gas Subgroup - Acetylene and Hydrogen
- Protection Mode nA - Non-sparking Apparatus
- Protection Mode nL - Energy Limited
- T4 represents a temperature code of the hottest surface that can be in contact with a gas.
- Ta is the temperature range

ATEX/FM Certified STB Modules

The following table lists all Advantys STB modules that are certified for operation in an explosive environment in accordance with the ATEX and FM ratings discussed above.

Model	ATEX (FM06ATEX 0010X)	FM North America
STB ACI 0320	II 3 G Ex nA IIC T4 Ta=0° - 60° C	CL 1, DV 2, GP ABCD T4 @ 70° C
STB ACI 1225	II 3 G Ex nA IIC T4 Ta=0° - 60° C	CL 1, DV 2, GP ABCD T4 @ 60° C
STB ACI 1230	II 3 G Ex nA IIC T4 Ta=0° - 60° C	CL 1, DV 2, GP ABCD T4 @ 70° C
STB ACI 8320	II 3 G Ex nA IIC T4 Ta=0° - 60° C	CL 1, DV 2, GP ABCD T4 @ 70° C
STB ACO 0120	II 3 G Ex nA IIC T4 Ta=0° - 60° C	CL 1, DV 2, GP ABCD T4 @ 70° C
STB ACO 0220	II 3 G Ex nA IIC T4 Ta=0° - 60° C	CL 1, DV 2, GP ABCD T4 @ 70° C
STB ACO 1210	II 3 G Ex nA IIC T4 Ta=0° - 60° C	CL 1, DV 2, GP ABCD T4 @ 70° C
STB ACO 1225	II 3 G Ex nA IIC T4 Ta=0° - 60° C	CL 1, DV 2, GP ABCD T4 @ 60° C
STB ART 0200	II 3 G Ex nA IIC T4 Ta=0° - 60° C	CL 1, DV 2, GP ABCD T4 @ 70° C
STB AVI 1225	II 3 G Ex nA IIC T4 Ta=0° - 60° C	CL 1, DV 2, GP ABCD T4 @ 60° C
STB AVI 1270	II 3 G Ex nA IIC T4 Ta=0° - 60° C	CL 1, DV 2, GP ABCD T4 @ 60° C
STB AVI 1275	II 3 G Ex nA IIC T4 Ta=0° - 60° C	CL 1, DV 2, GP ABCD T4 @ 60° C
STB AVO 1250	II 3 G Ex nA IIC T4 Ta=0° - 60° C	CL 1, DV 2, GP ABCD T4 @ 60° C
STB AVO 1255	II 3 G Ex nA IIC T4 Ta=0° - 60° C	CL 1, DV 2, GP ABCD T4 @ 60° C
STB AVO 1265	II 3 G Ex nA IIC T4 Ta=0° - 60° C	CL 1, DV 2, GP ABCD T4 @ 60° C
STB CPS 2111	II 3 G Ex nA IIC T4 Ta=0° - 60° C	CL 1, DV 2, GP ABCD T4 @ 70° C
STB DAI 5230	II 3 G Ex nA IIC T4 Ta=0° - 60° C	CL 1, DV 2, GP ABCD T4 @ 60° C
STB DAI 5260	II 3 G Ex nA IIC T4 Ta=0° - 60° C	CL 1, DV 2, GP ABCD T4 @ 60° C
STB DAI 7220	II 3 G Ex nA IIC T4 Ta=0° - 60° C	CL 1, DV 2, GP ABCD T4 @ 60° C
STB DAO 5260	II 3 G Ex nA IIC T4 Ta=0° - 60° C	CL 1, DV 2, GP ABCD T4 @ 60° C
STB DAO 8210	II 3 G Ex nA IIC T4 Ta=0° - 60° C	CL 1, DV 2, GP ABCD T4 @ 60° C
STB DDI 3230	II 3 G Ex nA IIC T4 Ta=0° - 60° C	CL 1, DV 2, GP ABCD T4 @ 70° C
STB DDI 3420	II 3 G Ex nA IIC T4 Ta=0° - 60° C	CL 1, DV 2, GP ABCD T4 @ 70° C
STB DDI 3425	II 3 G Ex nA IIC T4 Ta=0° - 60° C	CL 1, DV 2, GP ABCD T4 @ 60° C
STB DDI 3610	II 3 G Ex nA IIC T4 Ta=0° - 60° C	CL 1, DV 2, GP ABCD T4 @ 70° C
STB DDI 3615	II 3 G Ex nA IIC T4 Ta=0° - 60° C	CL 1, DV 2, GP ABCD T4 @ 60° C
STB DDI 3725	II 3 G Ex nA IIC T4 Ta=0° - 60° C	CL 1, DV 2, GP ABCD T4 @ 70° C
STB DDO 3200	II 3 G Ex nA IIC T4 Ta=0° - 60° C	CL 1, DV 2, GP ABCD T4 @ 70° C
STB DDO 3230	II 3 G Ex nA IIC T4 Ta=0° - 60° C	CL 1, DV 2, GP ABCD T4 @ 70° C
STB DDO 3410	II 3 G Ex nA IIC T4 Ta=0° - 60° C	CL 1, DV 2, GP ABCD T4 @ 70° C
STB DDO 3415	II 3 G Ex nA IIC T4 Ta=0° - 60° C	CL 1, DV 2, GP ABCD T4 @ 60° C

Model	ATEX (FM06ATEX 0010X)	FM North America
STB DDO 3600	II 3 G Ex nA IIC T4 Ta=0°- 60°C	CL 1, DV 2, GP ABCD T4 @ 70°C
STB DDO 3605	II 3 G Ex nA IIC T4 Ta=0°- 60°C	CL 1, DV 2, GP ABCD T4 @ 60°C
STB DDO 3705	II 3 G Ex nA IIC T4 Ta=0°- 60°C	CL 1, DV 2, GP ABCD T4 @ 70°C
STB EHC 3020	II 3 G Ex nA IIC T4 Ta=0°- 60°C	CL 1, DV 2, GP ABCD T4 @ 70°C
STB EPI 1145	II 3 G Ex nA IIC T4 Ta=0°- 60°C	CL 1, DV 2, GP ABCD T4 @ 60°C
STB EPI 2145	II 3 G Ex nA IIC T4 Ta=0°- 60°C	CL 1, DV 2, GP ABCD T4 @ 70°C
STB NCO 1010	II 3 G Ex nAnL IIC T4 Ta=0°- 60°C	CL 1, DV 2, GP ABCD T4 @ 60°C
STB NCO 2212	II 3 G Ex nAnL IIC T4 Ta=0°- 60°C	CL 1, DV 2, GP ABCD T4 @ 70°C
STB NDN 1010	II 3 G Ex nAnL IIC T4 Ta=0°- 60°C	CL 1, DV 2, GP ABCD T4 @ 60°C
STB NDN 2212	II 3 G Ex nAnL IIC T4 Ta=0°- 60°C	CL 1, DV 2, GP ABCD T4 @ 70°C
STB NDP 1010	II 3 G Ex nAnL IIC T4 Ta=0°- 60°C	CL 1, DV 2, GP ABCD T4 @ 70°C
STB NDP 2212	II 3 G Ex nAnL IIC T4 Ta=0°- 60°C	CL 1, DV 2, GP ABCD T4 @ 70°C
STB NFP 2212	II 3 G Ex nAnL IIC T4 Ta=0°- 60°C	CL 1, DV 2, GP ABCD T4 @ 70°C
STB NIB 1010	II 3 G Ex nAnL IIC T4 Ta=0°- 60°C	CL 1, DV 2, GP ABCD T4 @ 60°C
STB NIB 2212	II 3 G Ex nAnL IIC T4 Ta=0°- 60°C	CL 1, DV 2, GP ABCD T4 @ 60°C
STB NIP 2212	II 3 G Ex nAnL IIC T4 Ta=0°- 60°C	CL 1, DV 2, GP ABCD T4 @ 70°C
STB NMP 2212	II 3 G Ex nAnL IIC T4 Ta=0°- 60°C	CL 1, DV 2, GP ABCD T4 @ 70°C
STB PDT 2100	II 3 G Ex nA IIC T4 Ta=0°- 60°C	CL 1, DV 2, GP ABCD T4 @ 60°C
STB PDT 2105	II 3 G Ex nA IIC T4 Ta=0°- 60°C	CL 1, DV 2, GP ABCD T4 @ 60°C
STB PDT 3100	II 3 G Ex nA IIC T4 Ta=0°- 60°C	CL 1, DV 2, GP ABCD T4 @ 70°C
STB PDT 3105	II 3 G Ex nA IIC T4 Ta=0°- 60°C	CL 1, DV 2, GP ABCD T4 @ 60°C
STB XBE 3100	II 3 G Ex nA IIC T4 Ta=0°- 60°C	CL 1, DV 2, GP ABCD T4 @ 60°C
STB XBE 3105	II 3 G Ex nA IIC T4 Ta=0°- 60°C	CL 1, DV 2, GP ABCD T4 @ 60°C
STB XBE 1000	II 3 G Ex nA IIC T4 Ta=0°- 60°C	CL 1, DV 2, GP ABCD T4 @ 60°C
STB XBE 1100	II 3 G Ex nA IIC T4 Ta=0°- 60°C	CL 1, DV 2, GP ABCD T4 @ 70°C
STB XBE 1200	II 3 G Ex nA IIC T4 Ta=0°- 60°C	CL 1, DV 2, GP ABCD T4 @ 60°C
STB XBE 1300	II 3 G Ex nA IIC T4 Ta=0°- 60°C	CL 1, DV 2, GP ABCD T4 @ 70°C
STB XBE 2100	II 3 G Ex nA IIC T4 Ta=0°- 60°C	CL 1, DV 2, GP ABCD T4 @ 60°C

Maritime Environment

Overview

Advantys STB modules and associated components that are certified for maritime applications on board both commercial and naval vessels are described in this section. The certifying agencies and the classifications that the STB modules are approved for are described below.

ABS

The American Bureau of Shipping (ABS), both commercial and naval as follows:

Commercial-in accordance with ABS 2004 Steel Vessel Rules

Automatic, Remote Control and Monitoring of Propulsion (manned and unmanned) and Non-Propulsion Systems (ACC, ACCU, AMS), Security Systems, Electrical Control including Emergency Electrical Systems, use in Class I and II, Division 2 and Class III Divisions 1 and 2 Hazardous (Classified) Locations and Non-Hazardous (ordinary) Locations. (Ambient 60° C).

Naval -in accordance with ABS NVR Part 4.

Use below decks or inside protective enclosures. Automatic, Remote Control and Monitoring of Propulsion (manned and unmanned) and Non-Propulsion Systems, Security Systems, Electrical Control including Emergency Electrical Systems, use in Class I, Division 2 Hazardous Locations and Non-Hazardous (ordinary) Locations. (Ambient 60° C).

And 46 CFR 113.05-7. (Ambient 60° C).

Bureau Veritas (BV)

BV Rules for the Classification of Steel Ships E10-IEC 60092-504.

6.2- Approval valid for ships intended to be granted with the following additional Class notations: AUT-UMS, AUT-CCS, AUT-PORT and AUT-IMS.

The installation shall comply with the Manufacturer's recommendation described in the above-referenced documentation.

DNV Det Norske Veritas

Det Norske Veritas' Rules for Classification of Ships, High Speed & Light Craft and Det Norske Veritas' Offshore Standards

Temperature	A	5 to 55 °C
Humidity	A	Up to 96% Rh
Vibration	B	3 to 25 Hz, 1.6 mm,

		25 to 100 Hz, 4G
EMC	B	All locations including Bridge and Open Deck

Germanischer Lloyd (GL)

Guidelines for the Performance of Type Tests Part 2, Edition 2003
 GL Standard-Regulations for the Use of Computers and Computer Systems

Lloyds Register of Shipping (LR)

Marine, offshore and industrial applications for environmental categories ENV1, ENV2 and ENV4 as defined in LR Type Approval System, Test Specification No. 1-2002.

ENV1	Controlled environment to Producer's specification
ENV2	Enclosed spaces subject to temperature, humidity and vibration (+ 5 to +55 °C)
ENV4	Mounted on reciprocating machinery (+ 5 to +55 °C)(

Registro Italiano Navale Architects (RINA)

Rules for the Classification of Ships-Part C-Machinery, Systems and Fire Protection-Ch.3; Sect. 6; Tab.1.

Marine Certified STB Modules

The following table lists all the Advantys modules that are certified for operation in a maritime environment in accordance with the ratings discussed above.

Analog Input Modules

Model	Type	
STB ACI 0320	Cur, 4 ch, 4-20 mA, 16 bit	standard
STB ACI 1225	Cur, 2 ch, 4-20 mA, 10 bit	basic
STB ACI 1230	Cur, 2 ch, 0-20 mA, 12 bit	standard
STB ACI 1400	Cur, 8 ch, 4-20 mA, 16 bit single ended	standard
STB ACI 8320 (Hart tolerant)	Cur, 4 ch, 4-20 mA, 16 bit	standard
STB ART 0200	RTD/Tc/mV, 2 ch, 15 bit +sign	standard
STB AVI 0300	Volt, 4 ch wide range, 16 bit	standard
STB AVI 1255	Volt, 2 ch, 0 -10V, 10 bit	basic
STB AVI 1270	Volt, 2 ch, +/- 10V, 11bit + sign	standard

Model	Type	
STB AVI 1275	Volt, 2 ch, +/- 10V, 9bit + sign	basic
STB AVI 1400	Volt, 8 ch, wide range, 16 bit single ended	standard

Analog Output Modules

Model	Type	
STB ACO 0120	Cur, 1 ch, 4-20 mA, 16 bit	standard
STB ACO 0220	Cur, 2 ch, 4-20 mA, 16 bit	standard
STB ACO 1210	Cur, 2 ch, 0-20 mA, 12 bit	standard
STB ACO 1225	Cur, 2 ch, 4-20 mA, 10 bit	basic
STB AVO 0200	Volt, 2 ch, wide range, 16 bit	standard
STB AVO 1250	Volt, 2 ch, +/- 10V, 11 bit + sign	standard
STB AVO 1255	Volt, 2 ch, 0 +/-10V, 10 bit	basic
STB AVO 1265	Volt, 2 ch, +/- 10V, 9 bit + sign	basic

Digital Input Modules

Model	Type	
STB DDI 3230	24 VDC, 2pt sink, 4 wire	standard
STB DDI 3425	24 VDC, 4pt sink, 4 wire	basic
STB DDI 3615	24 VDC, 6pt sink, 2 wire	basic
STB DDI 3420	24 VDC, 2pt sink, 3 wire	standard
STB DDI 3610	24 VDC, 6pt sink, 2 wire	standard
STB DDI 3725	24 VDC, 16pt sink, 2 wire	basic

Digital Output Modules

Model	Type	
STB DAO 5260	115 VAC, isolated	standard
STB DAO 8210	115/230 VAC, 2pt source, 2.0A	standard
STB DDO 3200	24 VDC, 2pt source, 0.5A	standard
STB DDO 3230	24 VDC, 2pt source, 0.2A	standard
STB DDO 3410	24VDC, 4pt source, 0.5A	standard
STB DDO 3415	24VDC, 4pt source, 0.25A	basic
STB DDO 3600	24VDC, 6pt source, 0.5A	standard
STB DDO 3605	24VDC, 6pt source, 0.25A	basic
STB DDO 3705	24 VDC, 16pt source, 0.5A	basic

Model	Type	
STB DRA 3290	Relay, 2pt, 7.0A	standard
STB DRC 3210	Relay, 2pt, 2.0A	standard

Network Interface Modules

Network Protocol	NIM Model	Type
CANopen	STB NCO 1010	basic
	STB NCO 2212	standard
DeviceNet	STB NDN 1010	basic
	STB NDN 2212	standard
EtherNet/IP	STB NIC 2212	standard
Ethernet Modbus TCP/IP	STB NIP 2212	standard
	STB NIP 2311 (pending)	standard (dual-port)
FIPIO	STB NFP 2212	standard
INTERBUS	STB NIB 1010	basic
	STB NIB 2212	standard
Modbus Plus	STB NMP 2212	standard
Profibus DP	STB NDP 1010	basic
	STB NDP 2212	standard

Power Modules

Model	Type	
STB CPS 2111	Auxiliary Power Supply	
STB PDT 2100	standard	120/230 VAC Power Distribution
STB PDT 2105	basic	
STB PDT 3100	standard	24 VDC Power Distribution
STB PDT 3105	basic	

Special Purpose Modules

Model	Type
STB EHC 3020	High Speed Counter Multimode 40 kHz
STB EPI 1145	Tego Power 16 in/8 out parallel interface
STB EPI 2145	Tesys Type U 12 in/8 out parallel interface

Model	Type	
STB XBE 1100	EOS	extension module
STB XBE 1300	BOS	
STB XBE 2100	CANopen	

1.3 Initial Planning Considerations

Introduction

This section provides you with information that should be helpful in the early planning stages for an Advantys STB system. The subject matter includes the requirements for enclosing the STB island in a protective housing, determining the type of PDMs required for the island's field power needs, and examples of how to supply the logic and field power to the modules.

What's in this Section?

This section contains the following topics:

Topic	Page
Enclosing the STB Island	45
The Power Distribution Modules	52
Logic, Sensor and Actuator Power Distribution on the Island Bus	57
Power Supply Selection	64

Enclosing the STB Island

Open System Requirement

All Advantys STB modules meet CE mark requirements for open equipment and should be installed in an enclosure that meets NEMA 250 type 1 requirements and IP 20 requirements conforming to IEC 529. The enclosure should be designed to prevent:

- unauthorized access
- personal injury resulting from access to live parts

The specific environmental conditions under which the modules must operate should be considered in planning for the enclosure. Special consideration should be given to hazardous locations where a potentially explosive atmosphere (*see page 35*) may exist.

NOTE: The majority of Advantys STB modules are certified for use in explosive environments. Refer to ATEX/FM Certified STB Modules (*see page 37*) for a complete list of modules.

Size of the Enclosure

The size of the enclosure is determined by the number of modules that will makeup the island. One NIM and a maximum of 32 I/O modules are permitted per island which can be:

- standard Advantys STB
- optional preferred
- optional standard CANopen

In addition, PDMs, and an EOS or termination plate must be included in determining the total size of the island

Standard Module Dimensions

Advantys STB modules come in three different sizes and the dimensions for each of the sizes are listed in the following table.

Module size	Width of module alone	Height of module in base	Depth of module in base with field connectors
1	13.9 mm (.55 in.)	128.25 mm (5.05 in.)	75.5 mm (2.97 in.)
2	18.4 mm (.73 in.)	128.25 mm (5.05 in.)	75.5 mm (2.97 in.)
2-PDM	18.4 mm (.73 in.)	137.90 mm (5.45 in)	79.5 mm (3.13 in.)
3	28.1 mm (1.11 in.)	128.25 mm (5.05 in.)	70.1 mm (2.76 in)

These depth and height dimensions do not take into account the dimensions of external power equipment, preferred modules and/or standard CANopen devices.

The size and type of base for each of the Advantys STB modules is listed in the table on the following page.

STB Modules Size & Base Type

The following table lists the size and required base for each of the Advantys STB modules.

Model	Size	Base	Model	Size	Base
Analog Input Modules			Analog Output Modules		

Model	Size	Base	Model	Size	Base
STB ACI 0320	2	STB XBA 2000	STB ACO 0120	2	STB XBA 2000
STB ACI 1230	1	STB XBA 1000	STB ACO 0220	2	STB XBA 2000
STB ACI 1225	1	STB XBA 1000	STB ACO 1210	1	STB XBA 1000
STB ACI 1400	2	STB XBA 2000	STB ACO 1225	1	STB XBA 1000
STB ACI 8320	2	STB XBA 2000	STB AVO 0200	2	STB XBA 2000
STB ART 0200	1	STB XBA 1000	STB AVO 1250	1	STB XBA 1000
STB AVI 0300	2	STB XBA 2000	STBAVO 1255	1	STB XBA 1000
STB AVI 1270	1	STB XBA 1000	STB AVO 1265	1	STB XBA 1000
STB AVI 1275	1	STB XBA 1000	-----	--	-----
STB AVI 1255	1	STB XBA 1000	-----	--	-----
STB AVI 1400	2	STB XBA 2000	-----	--	-----
Digital Input Modules			Digital Output Modules		
STB DAI 5230	2	STB XBA 2000	STB DAO 5260	2	STB XBA 2000
STB DAI 5260	2	STB XBA 2000	STB DAO 8210	2	STB XBA 2000
STB DAI 7220	2	STB XBA 2000	STB DDO 3200	1	STB XBA 1000
STB DDI 3230	1	STB XBA 1000	STB DDO 3230	1	STB XBA 1000
STB DDI 3420	1	STB XBA 1000	STB DDO 3410	1	STB XBA 1000
STBDDI 3425	1	STB XBA 1000	STB DDO 3415	1	STB XBA 1000
STB DDI 3610	1	STB XBA 1000	STB DDO 3600	1	STB XBA 1000
STB DDI 3615	1	STB XBA 1000	STB DDO 3605	1	STB XBA 1000
STB DDI 3725	3	STB XBA 3000	STB DDO 3705	3	STB XBA 3000
-----	--	-----	STB DRC 3210	2	STB XBA 2000
-----	--	-----	STB DRA 3290	3	STB XBA 3000
Power Distribution Modules			Special Purpose Modules		
STB PDT 2100	2	STB XBA 2200	STB EHC 3020	3	STB XBA 3000
STB PDT 2105	2	STB XBA 2200	STB EPI 1145	2	STB XBA 2000
STB PDT 3100	2	STB XBA 2200	STB EPI 2145	3	STB XBA 3000
STB PDT 3105	2	STB XBA 2200	STB XBE 1000	2	STB XBA 2000
-----	--	-----	STB XBE 1100	2	STB XBA 2000

Spacing Requirements

Adequate clearance must be maintained between the modules installed in the enclosure and surrounding fixed objects such as wire ducts and inside surfaces. The following two illustrations show the spacing requirements within an enclosure

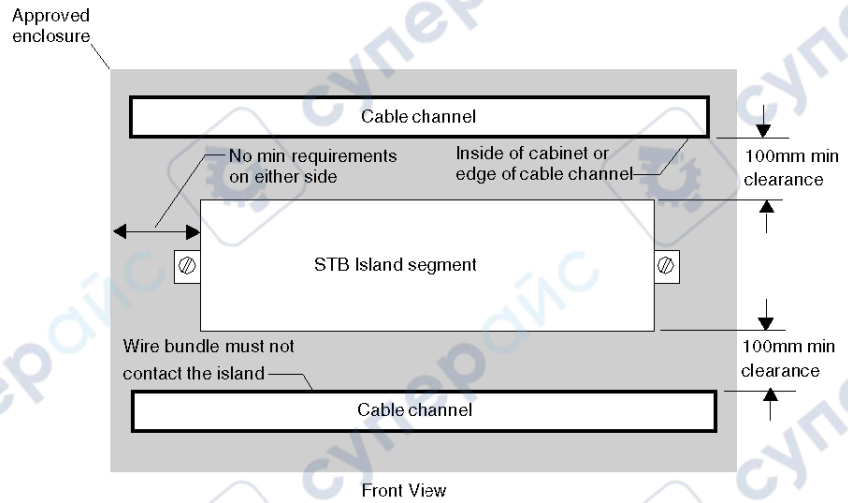

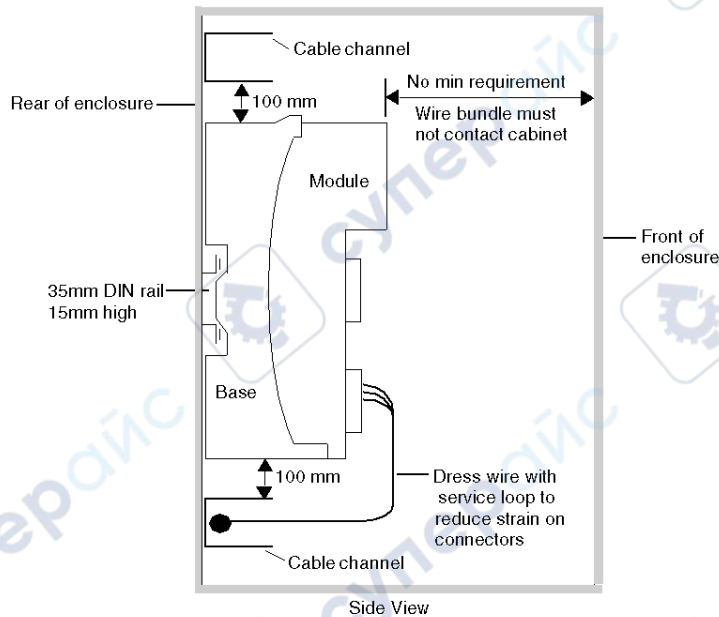

Mounting

The island is mounted on one or more 35 mm wide DIN carrier rails.

For EMC compliance, a metal DIN rail must be attached to a flat metal mounting surface or mounted on an EIA rack or in a NEMA cabinet enclosure. The physical backplane for the island is established by placing a NIM and a sequence of interlocked base units on the DIN rail (*see page 19*).

The standard DIN rail is 35 mm x 15 mm deep. For DIN rail mounting requirements (see page 76)

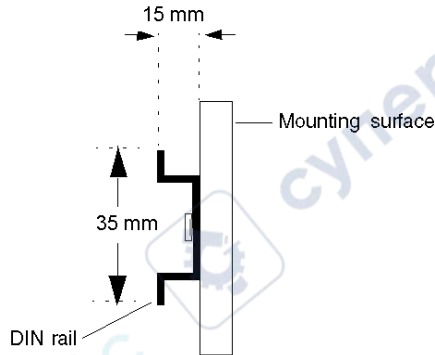

Wiring

Wiring must not obstruct the 100 mm (3.94) of free air space above and below the island segment. All wires must be secured to prevent undue load or strain on the STB modules. As shown in the side view (above), all leads from a harness or cable channel must be dressed with a service loop to reduce strain on the module.

Thermal Considerations

For proper heat dissipation, allow a minimum clearance of 100 mm (3.94 in) above and below each island segment. The vent openings on top and bottom of the modules must not be obstructed.

Listed below are some worst-case values for estimating the wattage dissipation when you plan the cooling for your system and cabinet enclosure:

Module Type	Module Width	Worst-case Wattage Value
inputs	size 1	1.5 W
	size 2	2.0 W
	size 3	3.5 W
outputs	size 1	1.0 W
	size 2	1.5 W
	size 3	3.5 W
special I/O	size 2	2.5 W
	size 3	3.5 W
CANopen extension	size 2	1.0 W
EOS	size 2	1.0 W

Module Type	Module Width	Worst-case Wattage Value
BOS	size 2	2.5 W
auxiliary power supply	size 2	2.5 W
DC PDM	size 2	1.5 W
AC PDM	size 2	1.5 W
NIM		3.5 W

The values above assume elevated bus voltage, elevated field-side voltage and maximum load currents. Typical wattage values are often considerably lower.

The Power Distribution Modules

Introduction

In the initial planning phase, the types of I/O modules that you select for each island segment will, in-turn determine the types of PDMs that are required. The following discussion should aid you in choosing the right PDMs.

Functions

A PDM distributes field power to a set of Advantys STB I/O modules on the island bus. The PDM sends field power to the input and output modules in a segment. Depending on the PDM module you are using (basic or standard-see below), it may distribute sensor power and actuator power on the same or on separate power lines across the island bus. The PDM protects the input and output modules with a user-replaceable fuse. It also provides a protective earth (PE) connection for the island.

Voltage Groupings

I/O modules with different voltage requirements need to be isolated from each other in the segment, and the PDMs serve this role. Each voltage group requires its own PDM. There are four STB PDMs to choose from:

Standard PDMs

- the STB PDT 3100 module, which distributes 24 VDC field power
- the STB PDT 2100 module, which distributes 115 VAC or 230 VAC field power

Basic PDMs

- the STB PDT 3105 module, which distributes 24 VDC field power
- the STB PDT 2105 module, which distributes 115 VAC or 230 VAC field power

The allowable lower and upper limits of the AC voltage supplied to an STB PDT 2100 or STB PDT 2105 PDM is between 85 VAC and 264 VAC.

Standard vs Basic PDMs

As indicated above, PDMs are available in both standard and basic types. When you use a standard PDM, it distributes power separately across the island's sensor bus to the input modules in its voltage group and along the island's actuator bus to all the output modules in its voltage group. When you use a basic PDM, sensor power and actuator power are tied together.

Standard PDM Power Distribution

A PDM is placed immediately to the right of the NIM in slot 2 on the island. The modules in a specific voltage group follow in series to the right of the PDM. The following illustration shows a standard STB PDT 2100 PDM supporting a cluster of digital 115 VAC I/O modules:

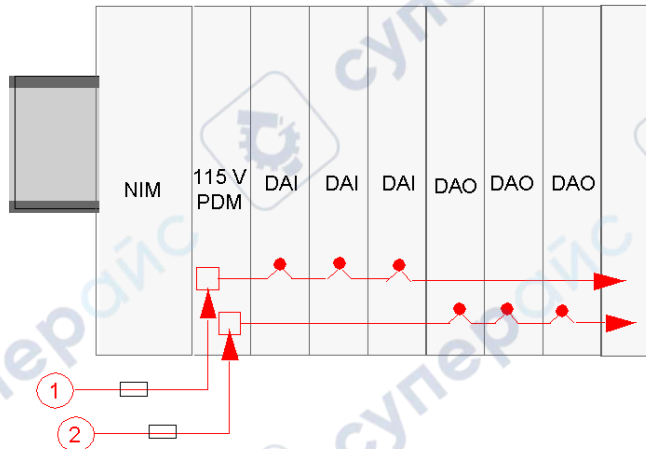

- 1 115 VAC sensor power signal to the PDM
- 2 115 VAC actuator power signal to the PDM

Notice that sensor power (to the input modules) and actuator power (to the output modules) are brought to the island via separate two-pin connectors on the PDM.

In the island layout shown above, all the digital I/O modules in the segment use 115 VAC for field power. Suppose, however, that your application requires a mix of 24 VDC and 115 VAC modules. A second PDM (this time a standard STB PDT 3100 module) is used for the 24 VDC I/O.

NOTE: When you plan the layout of an island segment that contains a mixture of AC and DC modules, we recommend that you place the AC voltage group(s) to the left of the DC voltage group(s) in a segment.

In this case, the STB PDT 3100 PDM is placed directly to the right of the last 115 VAC module. It terminates the sensor and actuator buses for the 115 VAC I/O voltage group and initiates new sensor and actuator buses for the 24 VDC modules:

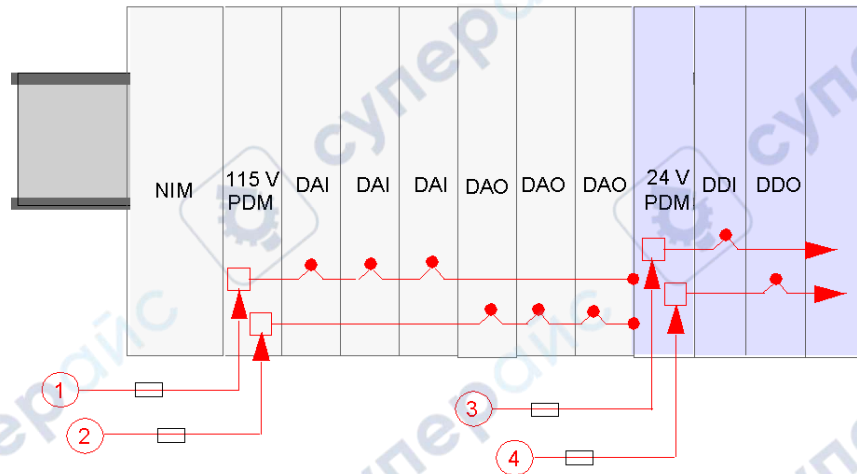

- 1 115 VAC sensor power signal to the PDM
- 2 115 VAC actuator power signal to the PDM
- 3 24 VDC sensor power signal to the PDM
- 4 24 VDC actuator power signal to the PDM

NOTE: Special limitations (*see page 30*) over the different operating temperature ranges are applicable to the STB PDT 3100 module (*see page 30*).

Each standard PDM contains a pair of time-lag fuses to protect the I/O modules in the segment. A 10 A fuse protects the output modules on the actuator bus, and a 5 A fuse protects the input modules on the sensor bus. These fuses are user-replaceable.

Basic PDM Power Distribution

If your island uses basic PDMs instead of standard PDMs, then actuator power and sensor power are sent over a single power line. In the following illustration, a basic STB PDT 2105 PDM is used for the 115 VAC actuator and sensor power and a basic STB PDT 3105 PDM supplies the 24 VDC power line.

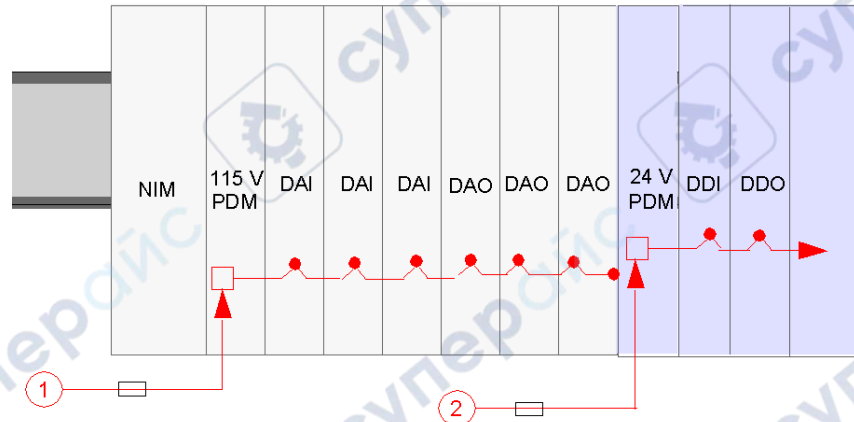

- 1 115 VAC sensor power signal to the PDM
- 2 24 VDC sensor power signal to the PDM

Each basic PDM contains on 5 A time-lag fuse that protects the I/O modules in the segment. This fuse is user-replaceable.

PE Grounding

A captive screw terminal on the bottom of the PDM base makes contact with pin 12 on each I/O base, establishing an island PE bus. The screw terminal on the PDM base meets IEC-1131 requirements for field power protection. The screw terminal should be wired to the PE point (see page 124) on your system.

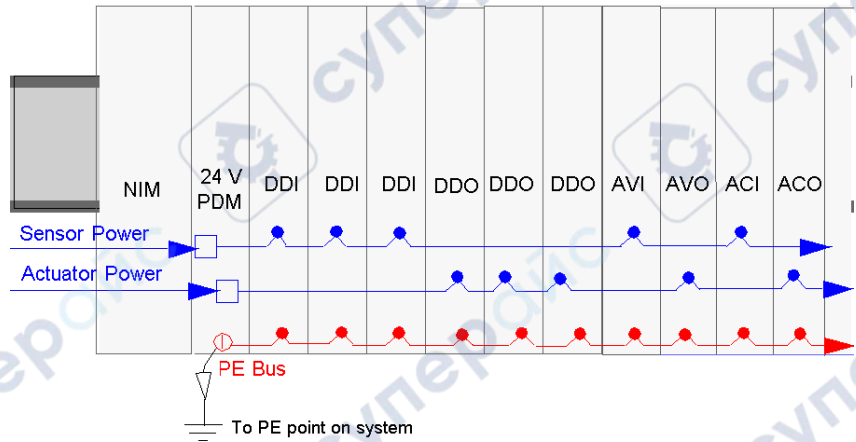

Logic, Sensor and Actuator Power Distribution on the Island Bus

Logic Power

Logic power is the 5 VDC power supplied by the NIM to the STB I/O modules. You need to supply 24 VDC to your NIM which converts it to 5 VDC for logic power in the primary segment of the island bus.

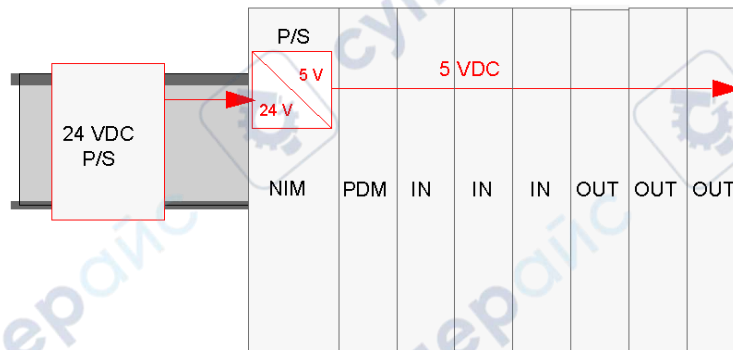

The maximum current draw from the I/O modules is limited to 1.2 A. If you place more I/O modules in the primary segment than the NIM's power supply can support (requiring more than 1.2 A of current), you may install an STB CPS 2111 auxiliary power supply to provide logic power to the additional I/O modules.

BOS modules on extension segments of an Advantys island also need their own 24 VDC for logic power, either from the same supply or from an additional one. The same 1.2 A current limit applies to each extension segment and an auxiliary power supply may also be used if the 1.2 A limit is exceeded.

NOTE: When operating in the extended temperature range of 60 to 70° C all standard NIM power supplies are limited to 575 mA maximum current output (see page 29) and the STB CPS 2111 auxiliary power supply and BOS modules are limited to 900 mA.

Here is an illustration of the extension segment scenario:

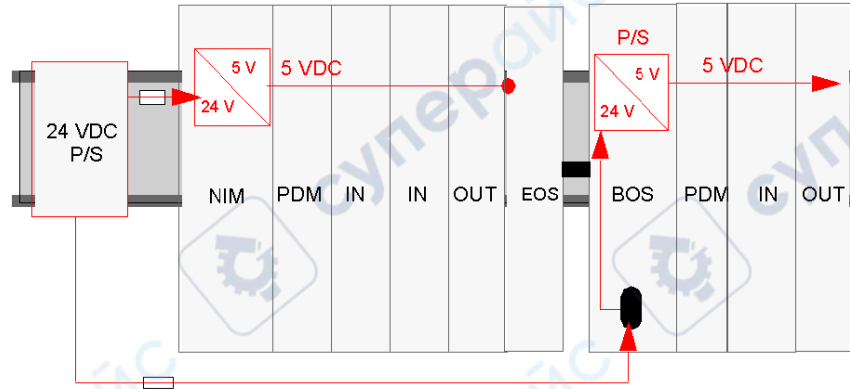

The external power supplies that you select to provide 24 VDC for logic power must have a low voltage limit of 19.2 VDC and a high voltage limit of 30 VDC.

Sensor and Actuator Power

⚠ CAUTION

IMPROPER GALVANIC ISOLATION

The power components are not galvanically isolated. They are intended for use only in systems designed to provide SELV isolation between the supply inputs or outputs and the load devices or system power buses. You must use SELV-rated supplies to provide 24 VDC source power to the NIM.

Failure to follow these instructions can result in injury or equipment damage.

The island's sensor and actuator buses need to be powered separately from external sources. Depending on the modules that make up the island segments, the field power requirements can be 24 VDC or 115/230 VAC, or a combination of both. The source power is fed to separate two-pin power connectors on the PDM.

- The top connector is for the sensor power bus
- The bottom two-pin connector is for the actuator power bus

Depending on your application, you may want to use the same or different external power supplies (*see page 65*) to feed the 24 VDC sensor and the actuator busses.

24 VDC Field Power Distribution

In the following illustration, an external power supply delivers 24 VDC power to a STB PDT 3100 PDM where it is distributed as field power to the island's sensor and actuator busses.

To assure that the installation will perform to system specifications, it is advisable to use a separate 24 VDC supply for logic power to the NIM and for field power to the PDM:

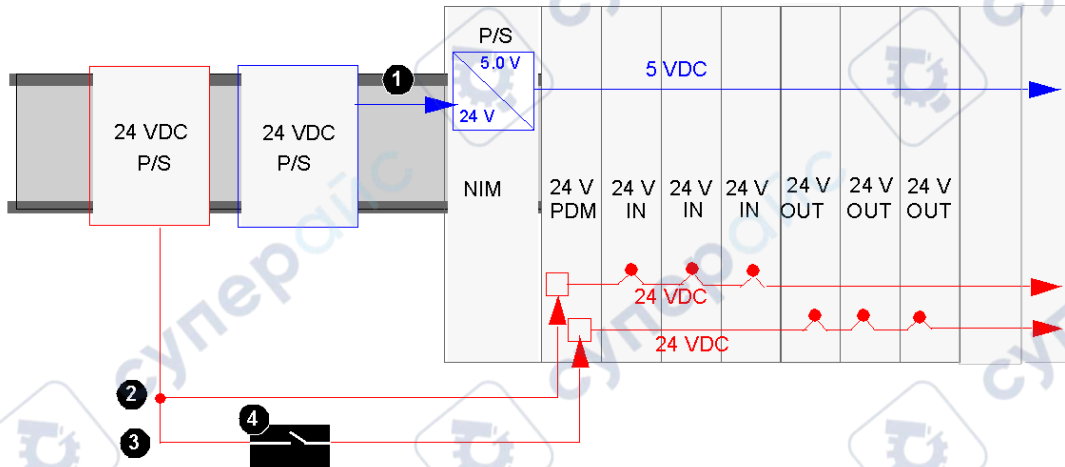

- 1 24 VDC signal to the NIM's logic power supply
- 2 24 VDC signal to the segment's sensor bus
- 3 24 VDC signal to the segment's actuator bus
- 4 optional relay on the actuator bus

⚠ CAUTION

COMPROMISED DOUBLE INSULATION

Above 130 VAC, the relay module may compromise the double insulation provided by a SELV-rated power supply.

When you use a relay module, use separate external 24 VDC power supplies for the PDM supporting that module and the logic power to the NIM or BOS module when the contact voltage is above 130 VAC.

Failure to follow these instructions can result in injury or equipment damage.

If the I/O load on the island bus is low and the system is operating in a low-noise environment, you may use the same supply for both logic power and field power:

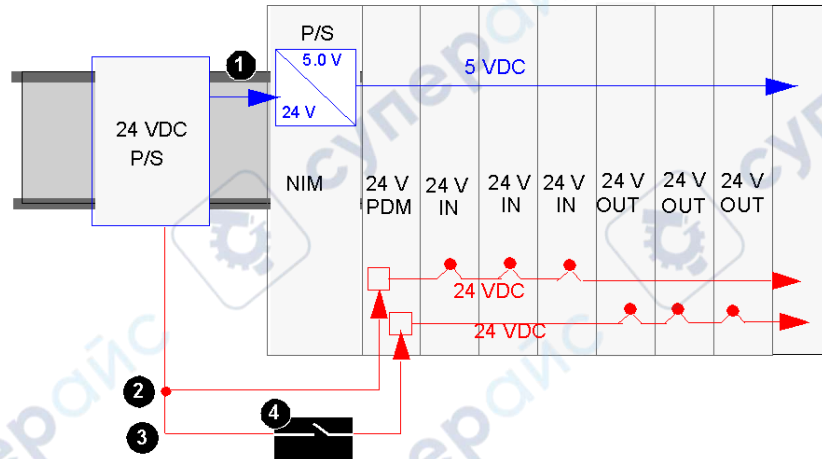

- 1 24 VDC signal to the NIM's logic power supply
- 2 24 VDC signal to the segment's sensor bus
- 3 24 VDC signal to the segment's actuator bus
- 4 optional relay on the actuator bus

NOTE: In the example above, a single power supply is used to provide 24 VDC to the NIM (for logic power) and the PDM. If any of the modules supported by the PDM is an STB relay module that operates at a contact voltage above 130 VAC, the double insulation provided by the SELV power supply is no longer present. Therefore, you will need to use a separate 24 VDC power supply to support the relay module.

The example below shows a 115 VAC PDM correctly wired to a two phase AC power supply.

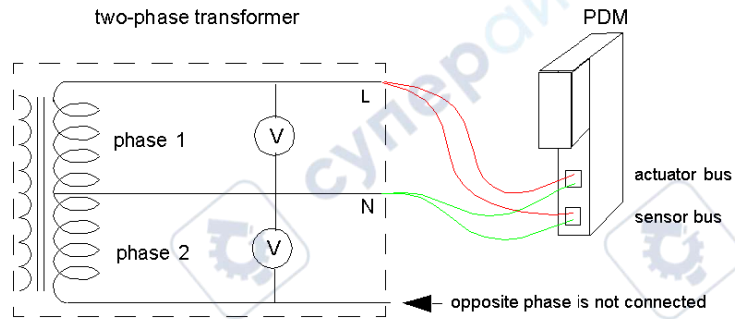

If the island segment contains a mixture of both 115 VAC and 230 VAC I/O modules, you must take care to install them in separate voltage groups and support the different voltages with separate STB PDT 2100 PDMs as is shown in the following illustration:

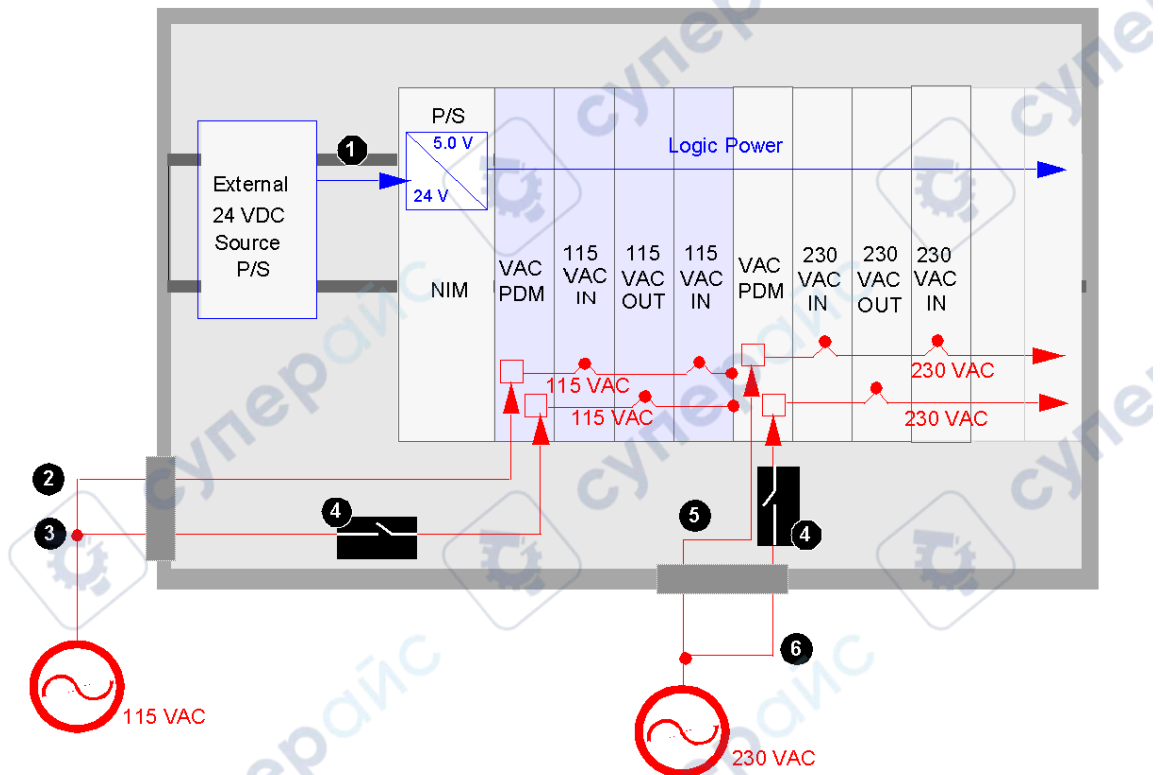

- 1 24 VDC signal to the NIM's logic power supply
- 2 115 VAC signal to the segment's sensor bus
- 3 115 VAC signal to the segment's actuator bus
- 4 optional relay on the actuator bus
- 5 230 VAC signal to the segment's sensor bus
- 6 230 VAC signal to the segment's actuator bus

NOTE: When an island bus is supporting both 115 VAC I/O modules and 230 VAC I/O modules, the 115 VAC modules and the 230 VAC modules must be in separate voltage groups behind separate PDMs.

Power Supply Selection

Overview

CAUTION

IMPROPER GALVANIC ISOLATION

The power components are not galvanically isolated. They are intended for use only in systems designed to provide SELV isolation between the supply inputs or outputs and the load devices or system power bus.

- You must use SELV-rated supplies to provide 24 VDC source power to the NIM and any BOS or auxiliary power supply modules in your system
- If you are using a relay module with a contact voltage above 130 VAC, do not use a common external 24 VDC power supply for the PDM supporting that module and the logic power in the NIM, auxiliary power supplies, or BOS modules
- Above 130 VAC, the relay module defeats the double insulation provided by a SELV-rated power supply

Failure to follow these instructions can result in injury or equipment damage.

In an Advantys STB island there may be three different connections that need 24 VDC power from an external source:

- logic power connection (to the NIM, to any auxiliary power supplies, and to any BOS extension modules in the island)
- actuator power connection (to a PDM)
- sensor power connection (to a PDM)

Source power for these can come from one or more supplies. Your requirements are dictated by:

- field devices
- voltage and current needs
- isolation requirements
- EMI/RFI suppression needs
- CE compliance needs
- cost limitations

Logic, Sensor and Actuator Power

You will need external 24 VDC power supplies to support the logic, sensor and actuator power requirements of each segment in your Advantys STB island. The power supplies that you choose must operate with a low voltage limit of 19.2 VDC and a high voltage limit of 30 VDC for a standard STB PDT 3100 or an basic STB PDT 3105 PDM.

Wattage Requirements

The NIM must be supplied at least 13 W of power. If your island uses extension segments, each BOS module on your island must be supplied at least 7 W of power. When selecting your power sources keep these power requirements in mind. For instance, if you have a NIM and a single BOS on your island and you are using a single supply, add their power requirements together to come up with the total power requirement for the single supply.

NOTE: If the 24 VDC source power supply also supplies field voltage to a PDM, you must add the field load to your wattage calculation. For 24 VDC loads, the calculation is simply $amps \times volts = watts$.

Recommended Supplies

We recommend the Phaseo ABL7 family of 24 VDC power supplies. Here are three possible power supply solutions to consider:

- one supply for three connections (logic power, actuator power and sensor power): ABL7 RP 2410 (10 A maximum)
- two supplies for three connections (one for logic power, one for actuator and sensor power)
For logic power: ABL7 RP 2402 or ABL RE 2402
For the 24 VDC PDM: ABL7 RP 2410 (10 A maximum)
- three supplies for three connections (one for logic power, one for actuator power and one for sensor power)
For logic power: ABL7 RP 2402 or ABL7 RE 2402
For the 24 VDC PDM sensor: ABL7 RP 2405 or ABL7 RE 2405 (5 A maximum)
For the 24 VDC PDM actuator: ABL RP 2410 (10 A maximum)

For more information on these recommended 24 VDC power supplies, contact your Schneider Electric representative.



Advantys STB System Installation Procedures

2

Overview

This chapter focuses on procedures for constructing the backplane for an island bus and installing modules on that bus to create an island segment. The chapter begins with a quick start guide that summarizes the steps involved in the installation process.

What's in this Chapter?

This chapter contains the following topics:

Topic	Page
Installation Quick Start Guide	68
The Layout of Modules on an Island Bus	71
The DIN Rail	76
Installing the NIM in the First Location on the Island	77
Keying Considerations	83
Interlocking Base Units on the DIN Rail	94
Terminating the Last Device on the Island	98
Installing Advantys STB Modules in their Bases	102

Installation Quick Start Guide

Introduction

This section provides a synopsis of the installation process covered in detail throughout the rest of this guide. The information is presented in generalized steps which convey each of the basic operations that are required in the installation process. Each step is accompanied by a reference that locates the detailed information associated with it. This "quick start style" should allow you to accomplish the installation of an STB island segment more efficiently, since you can skip the detailed discussions that you are already familiar with.

The installation process is divided into three phases described below.

Island Installation-Phase 1

In the first phase of the installation, you fasten down the DIM rail, install the NIM, key the modules, and attach the base units.

Step	Action	For Details See
1	Develop an installation plan that covers all aspects of the installation.	"Making a Plan" (see page 71)
2	Fasten the DIN rail to the mounting plate of the island enclosure.	"Carrier Rails for the Island Bus" (see page 76)
3	Install the NIM at the first (left most) location on the rail	"Installing the NIM..." (see page 77)
4	Determine the left-to-right arrangement of the modules on the rail.	"An Example of an STB Island" (see page 20)
5	Develop a keying scheme for the modules that matches the module layout (step 4).	"Keying Considerations" (see page 83)
6	Modify the keying pins on the bases and the keying slots on the modules in accordance with the keying scheme.	"How to Key the I o Module to Base Connection" (see page 86)
7	Attach the base units to the DIN rail in accordance with your module layout, working left to right from the installed NIM module (step 3, above).	"How to Attach the Base Units to the DIN Rail " (see page 95)
8	Install the last device of the island on the DIN rail. Use a termination plate for a single segment, or an EOS module if an extension segment is involved.	"Terminating the Last Device on the Island" (see page 98)

Island Installation-Phase 2

In the second phase of the installation, you install the modules and key the module field wire and power connectors.

Step	Action	For Details, see
1	Install the modules in their bases in accordance with your module layout (step 4, above).	"Installing Advantys STB Modules in their Bases" (see page 102)
2	Develop a keying scheme for the module field wire connectors.	"How to Key the Module Field Wire Connections" (see page 88)
3	Modify the keying pins on the module and field wire connectors in accordance with the keying scheme.	"How to Key the Module Field Wire Connections" (see page 88)
4	Develop a keying scheme for the NIM and PDM power connectors.	"How to Key the NIM power Connection" (see page 91)
5	Modify the keying pins on the NIM and PDM connectors in accordance with the keying scheme.	"Keying the PDM Power Connectors" (see page 91)

Island Installation-Phase 3

In the final phase, you take care of all grounding issues, install cable channels, make the necessary signal and power connections, and commission the island.

Step	Action	For Details, see
1	Install the EMC grounding bar.	"EMC Kits" (see page 127)
2	Make PE and FE grounding connections.	"Grounding Considerations" (see page 121)
3	Install cable channels and insert wiring harness.	"Cable Channels" (see page 75)
4	Make all field wiring connections.	
5	Connect the field bus master(PLC).	"Fieldbus Connection" (see page 138)
6	Make all power connections.	"Power Connections" (see page 138)

Step	Action	For Details, see
7	Dress all leads with adequate service loops to harness.	"Wiring" (see page 50)
8	Commission the island	"Configuring the Island" (see page 142)

The Layout of Modules on an Island Bus

Making a Plan

Before you begin to install the modules, you need to establish a solid plan that identifies:

- the type of enclosure for the island
- the number and type of I/O modules on your island
- their power requirements
- the order in which they will be placed on the island bus
- base unit needs
- a keying scheme that helps match the correct modules with their bases
- a labelling plan

Establishing and following a clear plan is necessary. The island bus will be constructed with a series of interconnected base units, and these base units are module-specific. The structure of the island backplane, therefore, will be defined by the type and order of modules that will reside in it. You will need to make these decisions in advance so that you can build the correct backplane, and key your base-to-module connections. Although there is inherent keying in the Advantys I/O system, optional keying of modules and connectors is available and recommended. Careful marking of your island base-to-module combinations is also recommended.

Selecting I/O Modules

When you plan an island layout, the most important things you need to know are the number and type of I/O modules and their matching bases. Once these two issues have been determined, it becomes easy to determine your external power requirements, power distribution requirements and the overall hardware design.

NOTE: For better immunity in noisy environments, in the event a segment consists of groups of AC *and* DC I/O modules, you should place the AC group before the DC group (from left to right). You should allow maximum distance between analog modules and the PDM.

If you are using a standard NIM

The island bus can support up to 32 I/O modules. These modules can be any combination of digital, relay, analog, and special-purpose Advantys STB modules and preferred modules. As many as 12 of these modules may be standard CANopen devices. If you use standard CANopen devices, they must be installed at the end of the island bus.

If you are using a basic NIM

The island bus can support up to 12 I/O modules. Only Advantys STB I/O modules may be used.

Positioning the STB I/O

The Advantys STB I/O modules need to be installed in structures called *segments*. A segment comprises a series of interconnected I/O, power distribution modules, and either a termination or extension device. These interconnected modules need to be inserted in bases that snap together on a DIN rail. These interconnected bases form the backplane over which the island bus passes:

- logic power
- island bus communications
- sensor and actuator field power
- protective earth ground (PE)
- functional earth ground (FE)

At least one segment must be included in the island.

If you are using a standard NIM

The required segment is called the *primary segment*. The primary segment is the first segment on the island and the one that contains the NIM. As many as six additional *extension segments* may be placed on the island after the primary segment. The island can support a maximum of 32 I/O modules. The I/O may be installed in a single segment or extended over multiple segments.

If the current load created by the I/O modules in any segment exceeds 1.2 A (see page 32), you need to use an STB CPS 2111 auxiliary power supply in that segment to support the extra I/O modules.

NOTE: For operation between 60 to 70° C, if the standard NIM total load current exceeds 575 mA, you need to use an STB CPS 2111 auxiliary power supply whose output must not exceed 900 mA.

Using bus extension cables and modules, you may extend a multi-segment island bus up to 15 m.

If you are using a basic NIM

Only one segment can be used. This basic segment can support up to 12 Advantys STB I/O modules and supports a fixed island bus baud rate of 800 kbaud.

Suggested Design Example

The following illustration shows an island with one segment terminated with a STB XMP 110 termination plate. Item 3, marking labels, are a suggested part of your design plan. They can be ordered from the Schneider catalog.

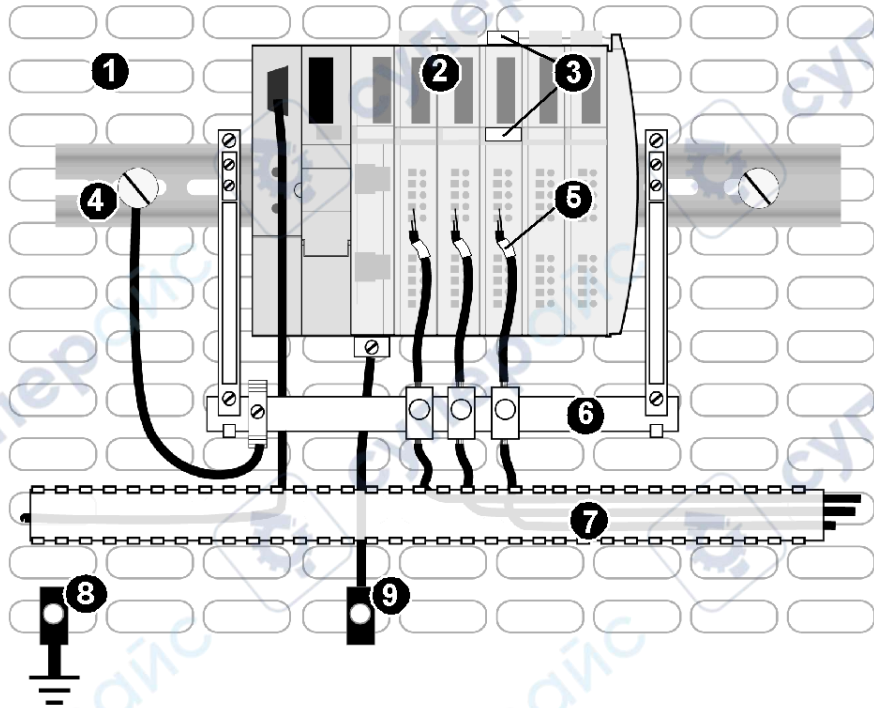

- 1 the DIN rail on a metal mounting surface and earth grounded grid
- 2 the island segment
- 3 STB XMP 6700 marking labels
- 4 functional earth (FE) grounding point
- 5 suggested label position (these labels are not provided by Schneider)
- 6 grounding bar from an STB XSP 3000 EMC kit, used as a FE point for shielded cables and as a cable stabilizer
- 7 a cable channel
- 8 6 mm² braided cable to plant ground
- 9 protective earth (PE) grounding point (made as close as possible to the I/O)

Determining Power Distribution Requirements

The island bus is designed to distribute field power to all its I/O modules over the island backplane. The modules used to distribute field power are called PDMs.

Standard and basic PDMs are available. standard PDMs transmit field power over two separate power buses—a sensor bus to the input modules and an actuator bus to the output modules. basic PDMs use a single field power connector to distribute both sensor and actuator power.

A PDM needs to be installed directly to the left of the I/O modules to which it is distributing field power. If you intend to support both DC I/O modules and AC I/O modules in the same segment, you will need to install different PDMs in the segment to support the different voltage groups.

As you plan your island layout, it is important to remember that all the I/O modules that require 24 VDC need to be placed together in a voltage group that is separated from any 115 or 230 VAC modules. Likewise, all I/O modules that require 115 VAC need to be separated from any 230 VDC modules in the segment.

NOTE: For better immunity in noisy environments, in the event a segment consists of groups of AC and DC I/O modules, you should place the AC group before the DC group (from left to right). You should allow maximum distance between analog modules and the AC modules, the relay modules, or the CPS 2111. For example, place the analog modules at the end of the DC group.

Labeling the Bases and the Modules

Each individual I/O base and module combination has two spaces on its front reserved for marking labels. Marking labels can help you quickly identify information on individual bases and modules. They can also help match I/O to the correct bases. The STB XMP 6700 label kit comes with a printer-friendly sheet of fifty 5 x 10 mm adhesive backed, prescored labels. They can be ordered from your Schneider representative. In addition, a label printing template is available on the CD that came with your NIM. The template can also be found on the User Doc CD (STB SUS 8800) that can be ordered from Schneider, and on the Schneider web site: www.telemecanique.com.

The following illustration shows the label areas on a module/base combination.

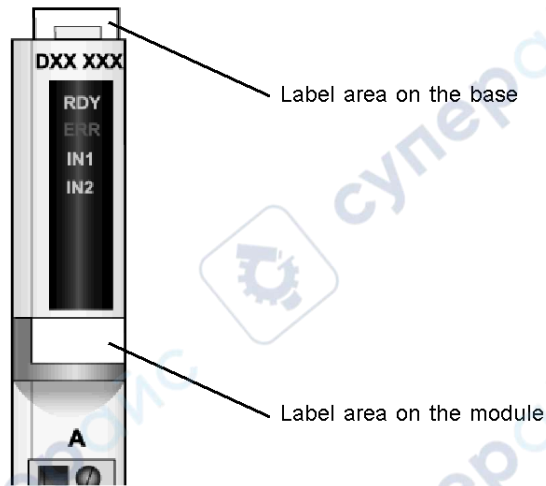

Cable Channels

Cable channels are recommended for an island's physical stability and ease of system assembly.

For thermal stability of the island, maintain a distance of 10 cm (3.94 in) between the tray and the island segment, as shown below.

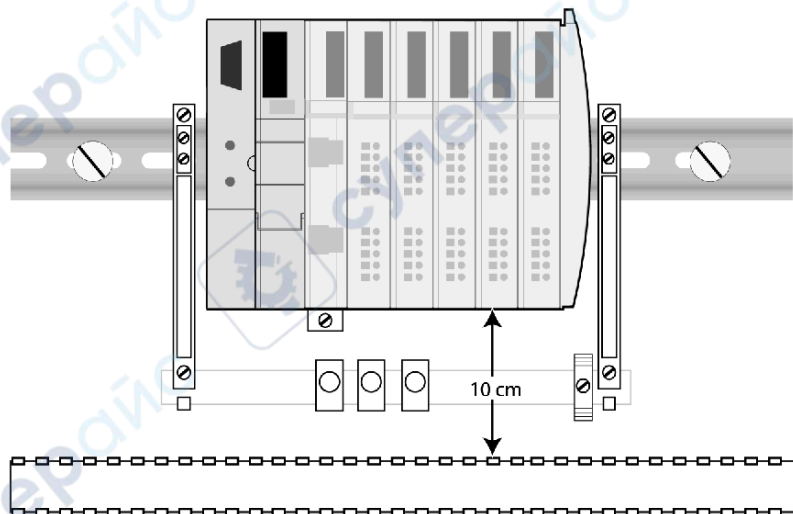

The DIN Rail

Carrier Rails for the Island Bus

The Advantys STB modules are designed for mounting on 35 mm x 15 mm deep DIN rail conforming to IEC 60715. The use of 15 mm deep DIN rail is required to achieve the stated system performance specifications. As shown on the following illustration, the mounting hardware must be installed at the end positions and at 150 mm maximum increments along the length of the rail.

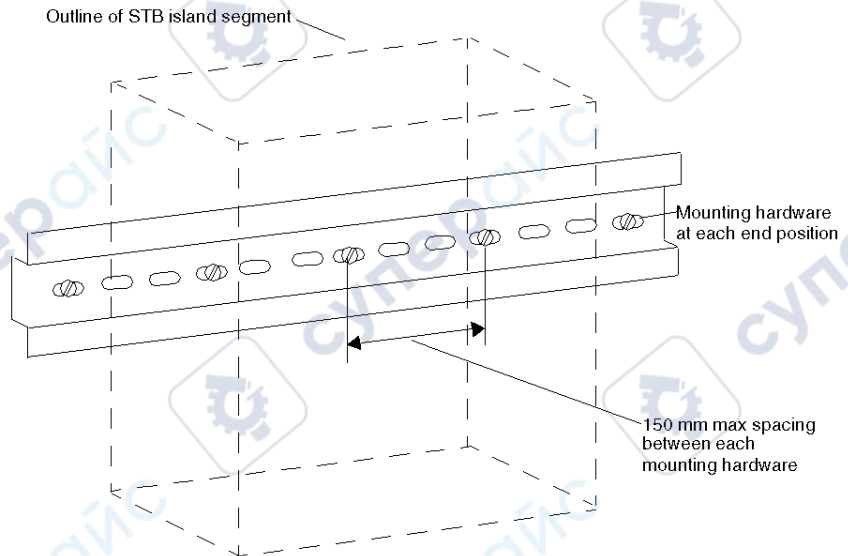

Low profile (7.5 mm deep) DIN mounting rail may be used with low profile mounting hardware such as flat head screws, with countersunk mounting holes.

NOTE: If low profile 7.5 mm deep DIN rail is used, ensure that the maximum fastener screw head protrusion does not exceed 1.0 mm above the surface of the DIN rail.

Grounding Function

The DIN rail provides the functional earth ground (*see page 126*) across the island.

Installing the NIM in the First Location on the Island

The First Module on the Island Bus

Every Advantys STB island must contain one and only one NIM. It is the first (leftmost) module on the DIN rail in the first segment.

Choosing the Correct NIM

Make sure that you have chosen the NIM model that is appropriate for the fieldbus protocol on which your island will operate.

Fieldbus	NIM Model	For more details, refer to the...	Part Number (language)
CANopen	STB NCO 2212 standard NIM	<i>Advantys STB Standard CANopen Network Interface Applications Guide</i>	31003684 (E), 31003685 (F), 31003686 (G), 31003687 (S), 31004621 (I)
	STB NCO 1010 basic NIM	<i>Advantys STB Basic CANopen Network Interface Applications Guide</i>	31005779 (E), 31005780 (F), 31005781 (G), 31005782 (S), 31005783 (I)
DeviceNet	STB NDN 2212 standard NIM	<i>Advantys STB Standard DeviceNet Network Interface Applications Guide</i>	31003680 (E), 31003681 (F), 31003682 (G), 31003683 (S), 31004619 (I)
	STB NDN 1010 basic NIM	<i>Advantys STB Basic DeviceNet Network Interface Applications Guide</i>	31005784 (E), 31005785 (F), 31005786 (G), 31005787 (S), 31005788 (I)
Ethernet Modbus	STB NIP 2212 standard NIM	<i>Advantys STB Standard Ethernet Modbus Network Interface Applications Guide</i>	31003688 (E), 31003689 (F), 31003690 (G), 31003691 (S), 31004622 (I)
	STB NIP 2311 standard NIM	<i>Advantys STB Standard Dual Port Ethernet Modbus TCP/IP Network Interface Applications Guide</i>	EIO0000000051 (E), EIO0000000052 (F), EIO0000000053 (G), EIO0000000054 (S), EIO0000000055 (I)
EtherNet/IP	STB NIC 2212 standard NIM	<i>Advantys STB EtherNet/IP Network Interface Applications Guide</i>	31008024 (E), 31008025 (F), 31008026 (G), 31008027 (S), 31008028 (I)
Fipio	STB NFP 2212 standard NIM	<i>Advantys STB Fipio Network Interface Applications Guide</i>	31003692 (E), 31003693 (F), 31003694 (G), 31003695 (S), 31004623 (I)
INTERBUS	STB NIB 2212 standard NIM	<i>Advantys STB Standard INTERBUS Network Interface Applications Guide</i>	31004624 (E), 31004625 (F), 31004626 (G), 31004627 (S), 31004628 (I)
	STB NIB 1010 basic NIM	<i>Advantys STB Basic INTERBUS Network Interface Applications Guide</i>	31005789 (E), 31005790 (F), 31005791 (G), 31005792 (S), 31005793 (I)

Fieldbus	NIM Model	For more details, refer to the...	Part Number (language)
Modbus Plus	STB NMP 2212 standard NIM	<i>Advantys STB Modbus Plus Network Interface Applications Guide</i>	31004629 (E), 31004630 (F), 31004631 (G), 31004632 (S), 31004633 (I)
Profibus DP	STB NDP 2212 standard NIM	<i>Advantys STB Standard Profibus DP Network Interface Applications Guide</i>	31002957 (E), 31002958 (F), 31002959 (G), 31002960 (S), 31002961 (I)
	STB NDP1010 basic NIM	<i>Advantys STB Basic Profibus DP Network Interface Applications Guide</i>	31005773 (E), 31005774 (F), 31005775 (G), 31005776 (S), 31005777 (I)

Also, check the product version (PV) of the NIM (*see page 29*) to ensure that it's qualified to operate within the temperature range it will be exposed to.

Notice that some of the NIMs are available in both standard and basic models. A standard NIM supports extension segments with up to 32 I/O modules, which may include Advantys STB I/O, preferred modules and/or standard CANopen devices. A basic NIM is a low-cost module that supports only one segment and is limited to 12 Advantys STB I/O modules. A basic NIM does not permit hot swapping of I/O modules.

How to Install the NIM

Unlike other Advantys STB modules, the NIM's mounting base is permanently attached to the module. The NIM is installed on the DIN rail in one piece. To install the NIM, use the following procedure:

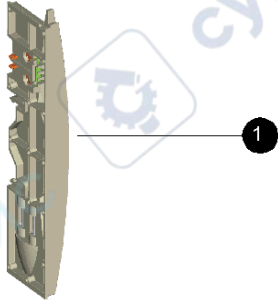
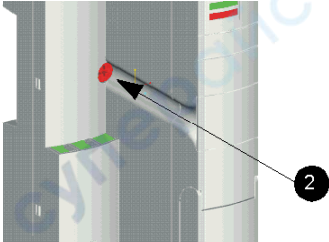
Step	Action
1	<p>Remove the STB XMP 1100 termination plate (1) from the NIM package and set it aside for later use.</p> 
2	<p>Choose the exact location on the DIN rail where you want to position the NIM before you place it on the rail. Note Do not slide the NIM on the rail—this could crush the functional earth (FE) contacts on the back of the NIM. Make sure that you have reserved enough space to the right of the NIM for all the other island modules you want to mount on the DIN rail. In addition, reserve enough space for any DIN-mounted external devices you intend to use, such as source power supplies and safety relays. If a 7 mm rail is used, make sure that there are no mounting screws located in the part of the rail where the island modules will be installed.</p>
3	<p>Turn the release screw (2) on the NIM so that the mounting clips on the back are in their relaxed state.</p> 

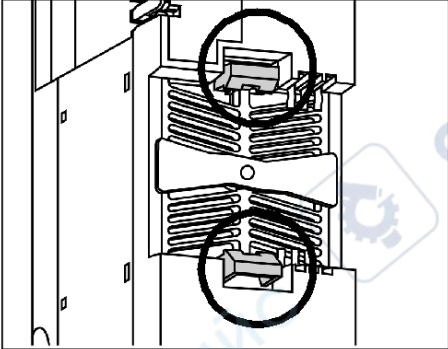
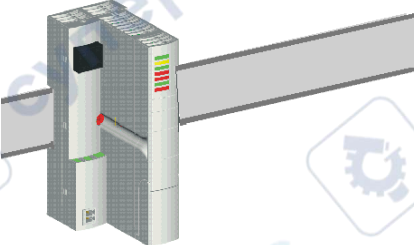
Step	Action
4	<p data-bbox="237 199 1234 251">Align the mounting clips with the DIN rail and push the NIM onto the rail. The slope of these clips allows them to be opened by the rail when light pressure is applied.</p> 
5	<p data-bbox="237 646 1234 673">When the module is pushed completely on to the rail, the clips will snap closed.</p> 

FE Contacts

One of the roles of the DIN rail is to provide a FE for the modules on the island. FE provides the island with noise immunity control and RFI/EMI protection. The contacts on the back of the NIM, shown in (3) below, make the functional ground connection between the rail and the NIM.

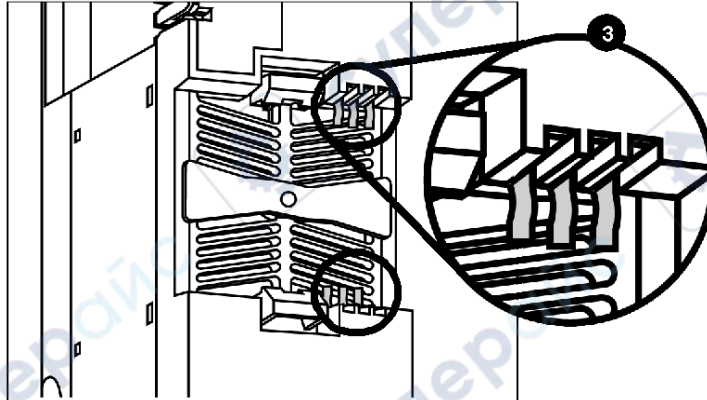

How to Remove a NIM from the DIN Rail

If for any reason you need to remove the NIM from the rail on which it has been mounted, follow these steps:

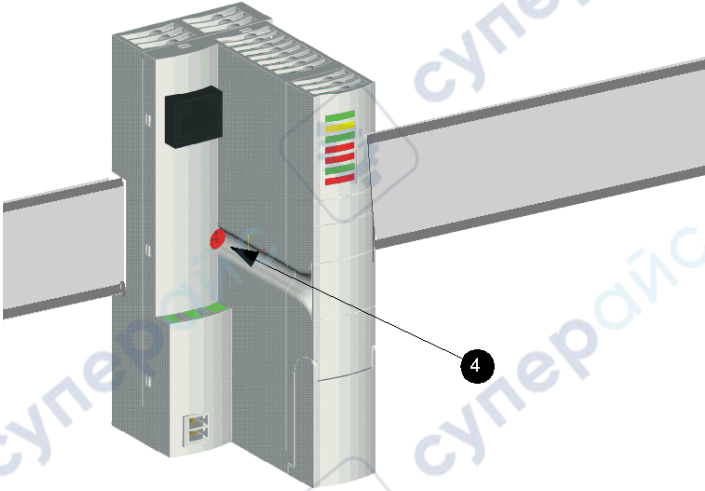
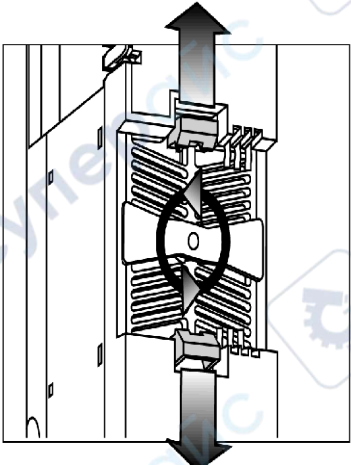
Step	Action
1	<p>Remove any Modules or PDMs that are mounted to the right of the NIM (start from the right and move left).</p> <p>Note: Base units do not need to be removed.</p>
2	<p>Loosen the NIM's grip on the rail via the release screw on the front of the module, as shown in (4) below.</p> 
3	<p>Use a small flathead screwdriver to turn the release screw 90 degrees in either direction. This will spread open the mounting clips on the back of the NIM, allowing you to pull it off the rail:</p> 

Keying Considerations

Overview

Consider using optional keying pins for inserting modules into their assigned bases and connectors into their assigned receptacles. Establish a keying scheme prior to attaching your I/O bases to the island's DIN rail.

In this manual we recommend a keying scheme for base-to-module connections only. Keying schemes for connectors are similar. Keys for modules must be ordered separately (see the keying kit table that follows). PDM connectors come with a set of their own keys.

NOTE: If your scheme includes keying the module to base connections, remove any break-off pins from the bases before installing them on the DIN rail.

Keying Kit Table

Keying pin kits are available for the I/O-to-base connection, the field wire connection (for sensor and/or actuator connections), the 24 VDC connection to the NIM, and the power connection on the PDM:

If you want to ...	Use a key from an ...	Key Quantity
key an I/O module to a base	STB XMP 7700 keying kit	60
key a field wire connection on the front of an I/O module	STB XMP 7800 keying kit	96
key a 24 VDC connection on a NIM		
key a PDM power connection	STB XMP 7800 keying kit	96
	STB XMP 7810 PDM keying kit	24

Creating a Keying Scheme

There are a multitude of keying schemes you can use in an Advantys STB island. Here are some strategies to keep in mind:

- key the top and bottom module connections differently
- key adjacent modules differently

Here is a sample keying scheme for base-to-module connections. It uses the six unique keying combinations, where a module with a different keying profile will not fit into any other uniquely keyed base. You may design your keying scheme with more than the six keying combinations. Verify your keying scheme prior to starting up your system.



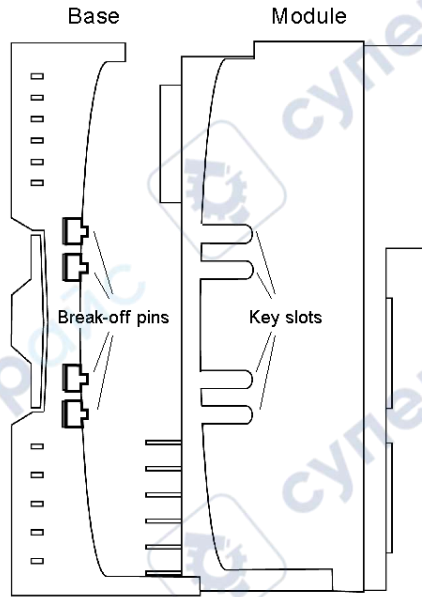





We are going to key all the base/module combinations on our island. We have decided to use the six unique keying patterns(#1 to #6) and one non-unique pattern (#7). The illustration below points out the key slots that will be left open or keyed and the break-off pins that will be left alone or removed:



Here are the combinations we will use to key our base/module combinations. The first six patterns are unique; the seventh is not.

A represents a slot with a key inserted. A represents a key slot without a key inserted. A represents a break-off pin present. A represents a break-off pin removed.

keying pattern #	Slots on the module	Break-off pins on the base
1	pattern: 	pattern:
2	pattern: 	pattern:
3	pattern: 	pattern:

keying pattern #	Slots on the module	Break-off pins on the base
4	pattern: 	pattern: 
5	pattern: 	pattern: 
6	pattern: 	pattern: 
7	pattern: 	pattern: 

The following table shows us where to add keys to, or remove break-off pins from, our modules and bases.

Module type	Key pattern to use
DC PDM <30 VDC	1
DC input	1
DC output	2
DC analog in	1
DC analog out	2
DC special purpose	3
AC in	4
AC out	5
AC special purpose	6
AC PDM 115 VAC	5
AC PDM 230 VAC	6
Auxiliary Power Supply	3
BOS	3
EOS	3
CANopen extension module	3

How to Key the I/O Module to Base Connection

To key an I/O-to-base connection, use the STB XMP 7700 keying kit. It comes with ten pinwheels. Each pinwheel has a set of keys that can be pushed into the desired key slots on the module according to your keying scheme. You can establish a unique keying pattern for up to 16 modules.

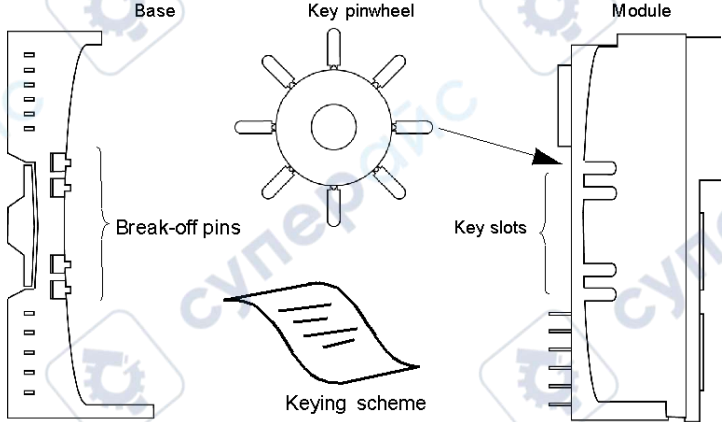
Step	Action
1	<p>To key a base to module connection you will need your keying scheme, a key pinwheel from kit #STB XMP 7700, the base free of the DIN rail, and the module free of the base.</p> 

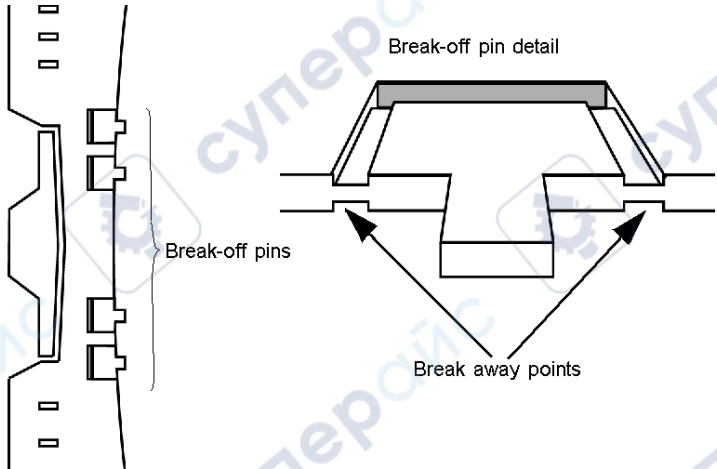
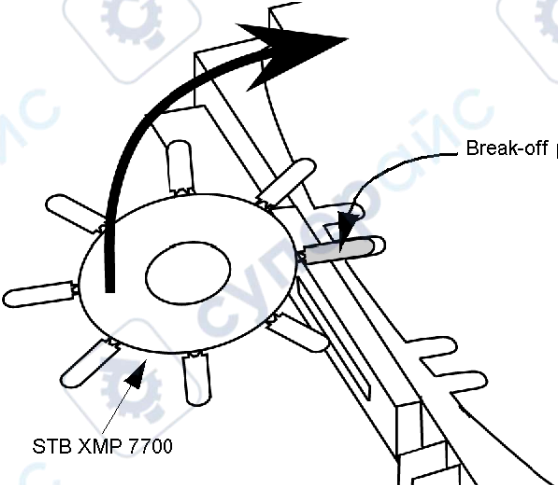
Step	Action
2	<p data-bbox="471 201 1208 250">Use a pair of needle nose pliers to break off the pins on the module base that correspond to your planned keying scheme.</p> 
3	<p data-bbox="471 753 1218 829">Push the key, still attached to the STB XMP 7800 pinwheel into the key slot on the module. Then lift the pinwheel to an angle sharp enough to break the key off of the pinwheel. Do this to as many key slots as your keying scheme dictates.</p> 

How to Key the I/O Module Field Wire Connection

Use an STB XMP 7800 keying kit to key an I/O module field wire connection. The keys can be inserted into the desired slots on the module per your keying scheme. When keying this connector, the key pin from the key pin wheel is pushed into the field wire receptacle at the front of the module, then the break off pin on the connector plug is broken off to match. Here are the steps for keying the field wire connections on your modules:

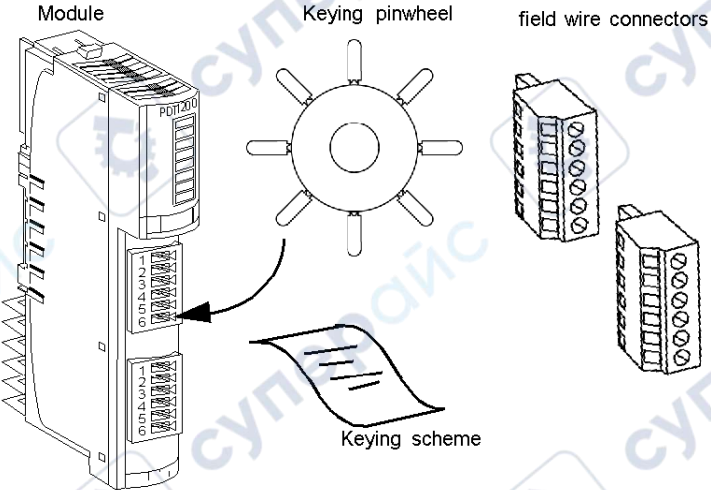
Step	Action
1	<p data-bbox="470 215 1221 321">To key a field wire connection on your module you will need your keying scheme, a key pin wheel from an STB XMP 7800 kit (or the keys that came with your connector kit), access to the front of the module, and the two field wire connectors separated from the module.</p>  <p>The diagram shows four items: a vertical module with a 'PDT 200' label and a terminal block; a circular 'Keying pinwheel' with six pins; two 'field wire connectors' of different sizes; and a 'Keying scheme' document with a curved arrow pointing to the module's terminal block.</p>

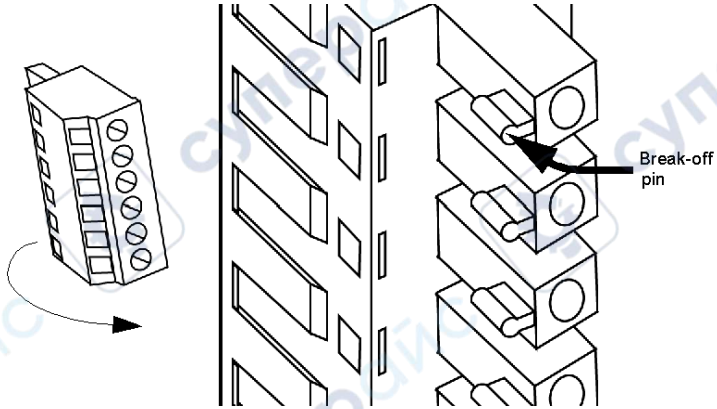
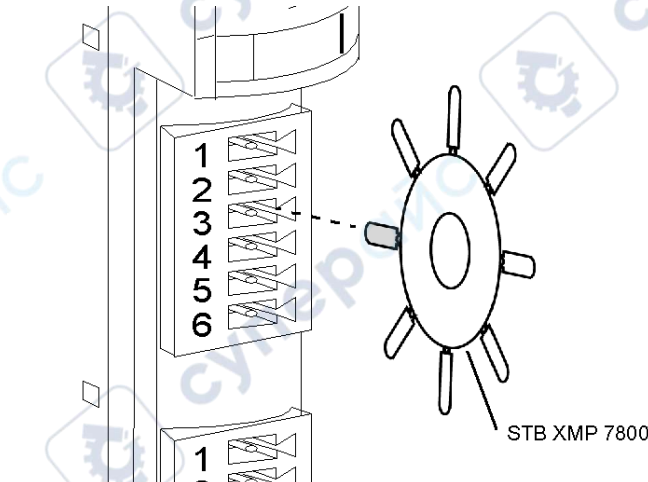
Step	Action
2	<p>Use a pair of needle nose pliers to break off the pins on the field wire connector that correspond to your planned keying scheme.</p> 
3	<p>Push the key, still attached to the pinwheel (STB XMP 7800), into the open key slot on the module. Then twist the pinwheel enough to break the key off of the pinwheel. Do this to as many key slots as your keying scheme dictates.</p> 

How to Key the NIM Power Connection

The NIM power connector is a two-pin version of the I/O connector. Follow the same steps in *Keying the I/O Field Wire Connection* above.

Keying the PDM Power Connection

Keying the scalloped power connection on the front of a PDM requires keying pins from two different kits, the STB XMP 7800 and STB XMP 7810 (or the keys that come with your connector kit). Keys need to be inserted in both the connector and its matching receptacle.

Step	Action
1	<p data-bbox="495 215 1238 318">To key a power connection on your PDM you need your keying scheme, a key pinwheel from the STB XMP 7800 kit (or the keys that came with your connector kit), another pinwheel from the STB XMP 7810 kit, access to the front of the PDM, and the two-pin power connectors separated from the PDM.</p> <div data-bbox="504 345 1193 836"> <p>The diagram illustrates the components required for the installation step. On the left is a vertical PDM (Power Distribution Module) unit. In the center are two circular pinwheels with pins extending from their perimeters. To the right are two two-pin connectors, one shown from the top and one from the side. Below the connectors is a document icon labeled 'Keying scheme'.</p> </div>

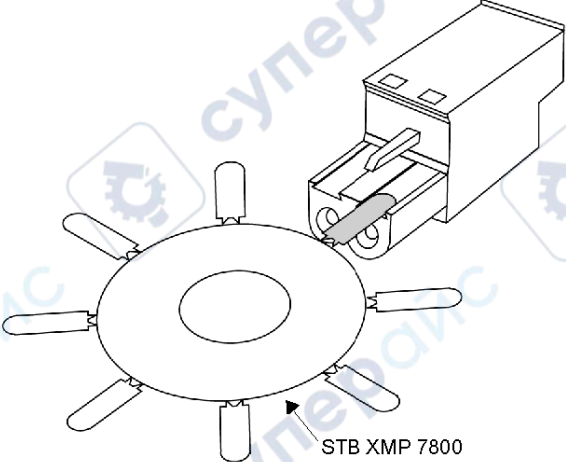
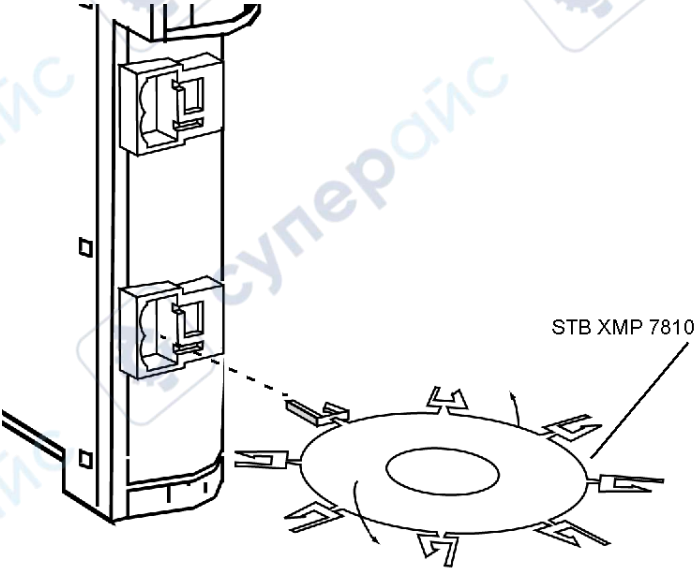
Step	Action
2	<p data-bbox="471 201 1223 277">Push the key, still attached to the STB XMP 7800 pinwheel all the way into the key slot on the connector plug. Lift or twist the pinwheel enough to break the key off of the wheel. Do this to as many key slots as your keying scheme dictates.</p>  <p data-bbox="801 732 945 753">STB XMP 7800</p>
3	<p data-bbox="471 786 1223 862">Push a key attached to the STB XMP 7810 pinwheel into the key slot on the receptacle on the front of the PDM. Then twist the pinwheel enough to break the key off of the wheel. Do this to as many key slots as your keying scheme dictates.</p>  <p data-bbox="1020 1192 1167 1213">STB XMP 7810</p>

Interlocking Base Units on the DIN Rail

The Backplane of the Island Bus

After the NIM has been attached to the DIN rail, attach the proper sequence of interconnected base units. Start directly to the right of the NIM with a PDM base unit, followed by a series of I/O base units. Base units are installed from left to right along the rail. These base units together with the NIM will form the backplane for the primary segment of the island.

The following illustration points out features important in connecting base units to the DIN rail.

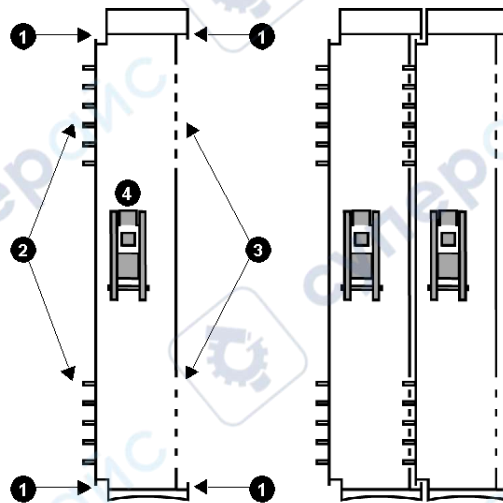

- 1 interlocking channels
- 2 contacts
- 3 contact channels
- 4 DIN rail latch

NOTE: If your plan includes keying the modules to their base connections (see page 86), remove any break-off pins from the bases before installing them on the DIN rail.

The Base Units

The following table lists the base types.

Base Model	Base Width	Advantys STB Modules It Supports
STB XBA 1000	13.9 mm (0.53 in)	size 1 I/O modules
STB XBA 2000	18.4 mm (0.71 in)	size 2 I/O modules and CANopen extension modules
STB XBA 2100	18.4 mm (0.71 in)	the STB CPS2111 auxiliary power supply
STB XBA 2200	18.4 mm (0.71 in)	DC and AC PDMs
STB XBA 2300	18.4 mm (0.71 in)	the BOS module
STB XBA 2400	18.4 mm (0.71 in)	the EOS module
STB XBA 3000	28.1 mm (1.06 in)	size 3 modules

How To Attach Base units to the DIN Rail

The following table describes the PDM base unit insertion procedure. Always work from left to right.

Step	Action
1	Working from your installation plan, select an STB XBA 2200 base unit for the PDM that will be located directly to the right of the NIM.
2	Remove any break-off pins that correspond to your keying scheme.
3	Using a screwdriver, move the DIN rail latch on the base unit to its full open position.

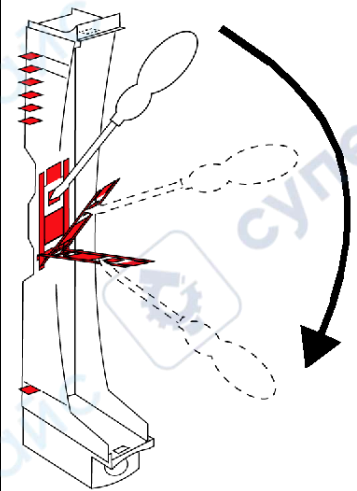

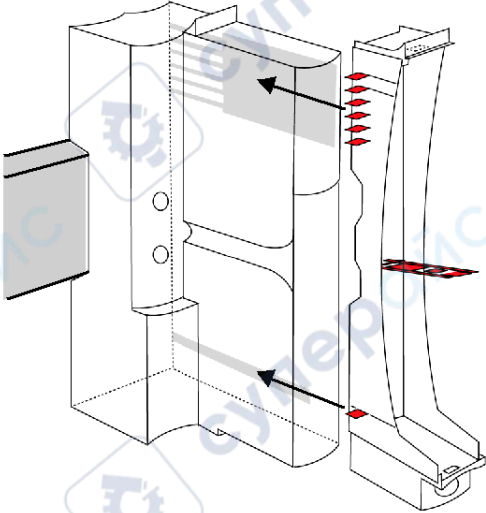
Step	Action
4	<p>Align the contacts on the base with the contact channels on the NIM and push the base toward the DIN rail until the interlocking channels meet. Using the interlocking channels as guides, slide the base toward the DIN rail (push from the center of the base). When the base meets the DIN rail hold the base unit firmly against the DIN rail and push the DIN rail latch into the locked position.</p> 
5	<p>Working from your installation plan, select the correct base unit for the module that will be located directly to the right of the previous base unit, and repeat steps 2 ...5</p>

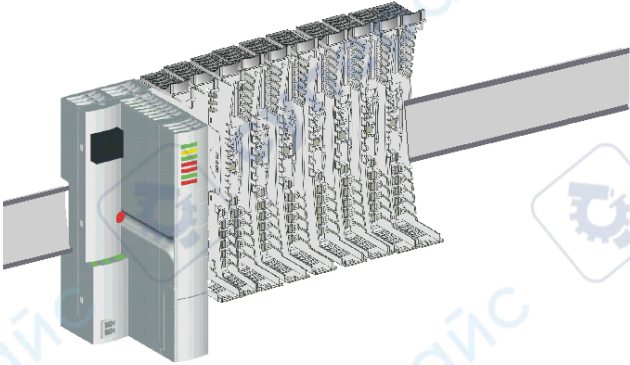
Step	Action
6	<p data-bbox="454 201 1208 250">Repeat steps 2 ... 4 until base units for all the I/O and PDM modules in the primary segment are installed.</p> 
7	<p data-bbox="454 693 1199 742">Refer to the procedures in the next section for information on installing the last device in the segment.</p>

Terminating the Last Device on the Island

One or More Segments?

The last device on the island bus needs to be terminated with a 120 Ω terminator resistor. If the island bus is a single segment (without *extension segments*), that segment needs to be terminated with the STB XMP 1100 termination plate which houses a 120 Ω termination resistor. If the island bus is extended to either another segment of Advantys STB modules or a preferred module, terminate only the last segment or the last module on the island bus. If you are extending the island to a standard CANopen device, you need to terminate both the last segment on the island bus (with the STB XMP 1100 termination plate) and the last standard CANopen device on the island (with termination supplied for that device).

NOTE: If you want to use extensions of any kind as part of your island bus, you must use a standard NIM (see page 77). The low-cost basic NIMs do not support extensions.

Termination Options

The following table describes the different ways to terminate the island bus, depending on the type of installation.

If the island bus...	then...
comprises just one segment with no extensions	terminate the segment with an STB XMP 1100 termination plate.
is extended to another segment of Advantys STB modules	install an STB XBA 2400 base at the end of the segment. This base will hold an STB XBE 1000 or STB XBE 1100 end of segment EOS module. Terminate at the end of the last segment with a SCB XMP 1100 termination plate. the EOS module provides an interconnect for a bus extension cable that will run to the matched STB XBE 1200 or STB XBE 1300 beginning-of-segment (BOS) module in the first location of the extension segment.

If the island bus...	then...
is extended to a preferred module	<p>install an STB XBA 2400 base at the end of the segment. This base will hold an STB XBE 1100 EOS module. Terminate at the last preferred module using the preferred module termination resistor (supplied with the preferred module), or at the end of the last segment with a SCB XMP 1100 termination plate.</p> <p>the EOS module provides an interconnect for a bus extension cable that will run to the preferred module.</p> <p>the STB XBE 1000 EOS or STB XBE 1200 BOS modules cannot be used with preferred modules.</p>
is extended to a standard CANopen device	<p>install an STB XBA 2000 base at the end of the segment. Terminate at the last CANopen device using the CANopen termination resistor, or at the end of the last segment with a SCB XMP 1100 termination plate. STB XBA 2000 base houses an STB XBE 2100 CANopen extension module.</p> <p>the CANopen extension module provides an interconnect for a standard CANopen cable that will run to the CANopen device. the standard CANopen device/s will be the last device on the island.</p>

How to Terminate the Last Segment

Use the following procedure when you terminate the last segment on the island bus:

Step	Action
1	<p>Find the STB XMP 1100 termination plate that you set aside when you unpacked your NIM.</p> <p>If you cannot locate the plate that shipped with the NIM, it can be ordered by its STB XMP 1100 model number as a standalone accessory.</p>

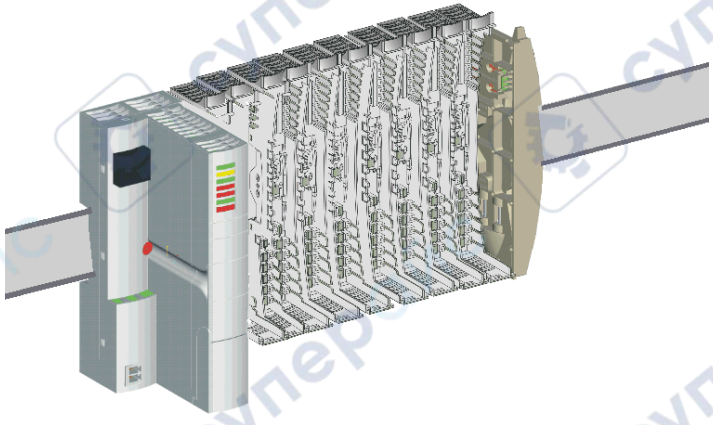
Step	Action
2	Align the interlocking channels at the top and bottom left of the termination plate with the channels on the right side of the last I/O base.
3	<p>Using the interlocking channels as guides, slide the plate toward the DIN rail until it snaps onto the rail.</p>  A 3D cutaway diagram showing a grey termination plate being inserted into a grey DIN rail. The plate has a red interlocking channel on its top edge and a green interlocking channel on its bottom edge. The DIN rail has corresponding channels on its right side. The plate is shown partially inserted, with the interlocking channels aligning. The plate has a multi-colored status indicator (red, yellow, green, blue) on its front face. The DIN rail is shown in a perspective view, with the termination plate being inserted from the left side.

How to Remove a Termination Plate

Use the following procedure to remove a termination plate from the end of a segment.

Step	Action
1	Remove the module directly to the left of the STM XMP 1100 termination plate.
2	With a firm grip on the lip at the center of the termination plate, pull the plate straight out from its channel guides.

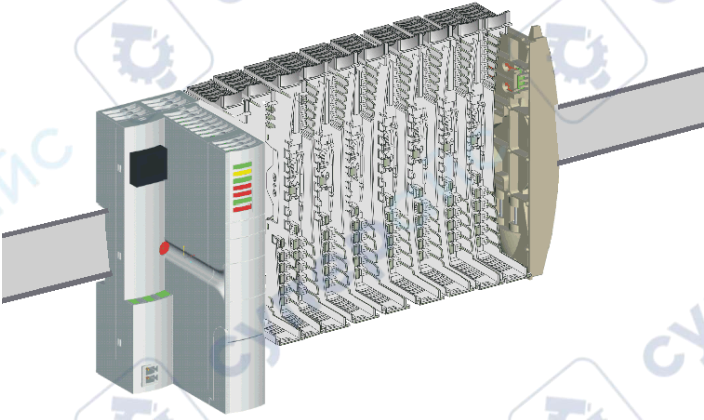

Installing Advantys STB Modules in their Bases

Summary

The insertion of an Advantys STB module into its base is very simple; the module slides into its base and locks with snap latches. The important thing to remember is that you need to match the correct module with its appropriate base. For this reason, an installation plan should be made before you begin the actual installation process. The following procedures are to be implemented without power connected to the island. For procedures implemented under power, see *Hot Swapping Advantys STB I/O Modules*, page 146.

Preliminary Considerations

Before you install the modules in their bases, we recommend that you:

- Make sure that you have the correct base in each position on the island backplane
- Use a keying strategy (*see page 86*) to help avoid installing a module in the wrong base
- Use the STB XMP 6700 marking label kit to clearly match modules to their bases

How to Insert a Module in a Base

Do the following:

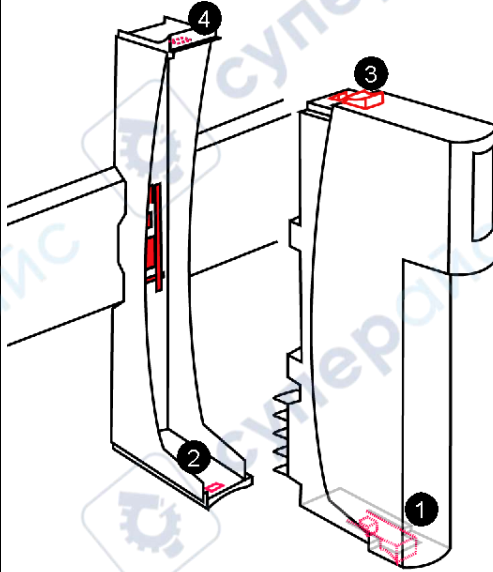
Step	Action
1	<p>Guide the bottom of the module into the tray at the bottom of the base.</p>  <p>1 Module base latch 2 Module base 3 Module to base unit latch (top) 4 Module to base unit latch (bottom)</p>
2	<p>Push the bottom of the module toward the back of the base until the latch (1) fully engages the bottom of the base (2) and you hear an audible <i>snap</i>.</p>

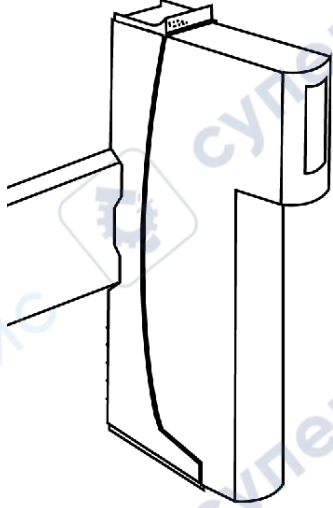
Step	Action
3	<p>Push the top of the module inward until the latch (3) fully engages the top of the base (4) and you hear an audible <i>snap</i>.</p> 
4	<p>Pull outward on the module to verify that it is securely latched. Note: It's important to follow the above steps and to hear the audible <i>snap</i> to ensure positive latching of the module.</p>

How to Remove a Module from its Base

To remove an I/O module from its base:

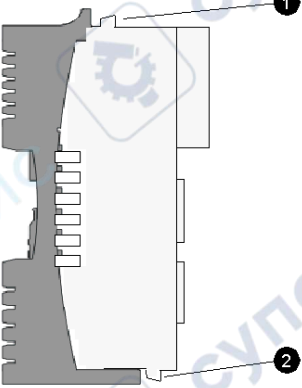
Step	Action
1	Remove any connectors from the module.
2	Using both your hands, release the module from the base by depressing the two module to base latches on the module.  <ul style="list-style-type: none">1 Module to base latch (top)2 Module to base latch (bottom)
3	With a rocking motion, slowly pull the module evenly out of the base.



Extending an Advantys STB Island Bus

3

Why Extend the Island Bus?

There are four key reasons why you might want to extend the island bus beyond the primary segment:

- mechatronic design considerations requiring more distance to keep the I/O modules closer to the sensor and actuator devices
- the need for one or more preferred module(s) on the island bus
- the need for standard CANopen devices on the island bus
- cabinet size limitations

NOTE: Island extensions require the use of a standard NIM. Low-cost basic NIMs do not support island bus extensions.

What's in this Chapter?

This chapter contains the following topics:

Topic	Page
Island Bus Extensions	108
Installing Extension Segments of Advantys STB Island Modules	109
Installing a Preferred Module Extension	114
Installing an CANopen Device Extension	118

Island Bus Extensions

Bus Extensions

The island bus can be extended in several ways:

- with additional extension segments of Advantys STB I/O
- with one or more preferred modules
- with one or more standard CANopen devices (up to a maximum of 12)

NOTE: The following discussion assumes that you are using one of the standard NIMs in your island configuration. The low-cost basic NIMs do not support extension segments, preferred modules or standard CANopen devices.

Maximum Length Considerations

The maximum length permissible for an island bus is 15 m (49.2 ft) end-to-end.

The maximum length must take into consideration:

- The width of all Advantys modules in all segments
- The width of all preferred modules and/or standard CANopen devices on the island bus
- All extension cables between island segments and between segments and standalone modules

The maximum island bus length does not include the space required for supporting devices that are not part of the island (such as external 24 VDC power supplies) and the wiring between these devices and the island.

Installing Extension Segments of Advantys STB Island Modules

Preliminary Considerations

An island bus can support up to six extension segments of Advantys STB I/O modules in addition to the primary segment. Extension segments may be installed on the same, or on separate DIN rails. The STB XBE 1200 and STB XBE 1300 beginning of segment (BOS) module is connected via an island bus extension cable to the previous segment.

You can use the configuration software to design your island or use information from the I/O book to do a design on paper.

How to Build an Extension Segment

An extension segment is built in much the same way as the primary segment. Instead of using a NIM in the first location, a BOS module is installed.

The BOS module mounts in a special size 2 base, the STB XBA 2300. A BOS delivers logic power across the extension island backplane. Just as with the NIM, a BOS module needs to be connected to an external 24 VDC power supply.

The rest of the modules are assembled the same as in a primary segment. The second module is a PDM followed by a voltage group of I/O modules.

The last device in the segment may be:

- an STB XMP 1100 termination plate, if this is the end of the island bus
- an STB XBE 1000 or STB XBE 1100 EOS module, if the island bus is to be extended to another segment of STB I/O modules
- an STB XBE 1100 EOS module, if the island bus is to be extended to a preferred module
- a preferred module termination resistor, if the end of the island bus is with a preferred module or the last preferred module.

Extension Segment Requirements

When joining island bus segments together, it is important to note that only paired EOS/BOS modules work in conjunction with one another.

The following EOS and BOS modules are used exclusively with one another between island segments:

EOS Module	BOS Module
STB XBE 1000	STB XBE 1200
STB XBE 1100	STB XBE 1300

For example, if an STB XBE 1000 EOS module is connected in the previous island segment, you must connect an STB XBE 1200 BOS module to the beginning of the next island segment. Multiple island segments can have different paired EOS/BOS modules.

The following figure shows compatible EOS/BOS modules joined on an island with multiple segments:

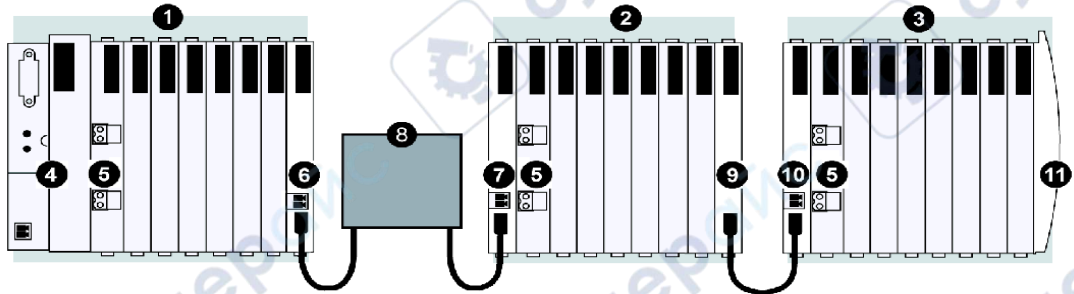

- 1 primary island segment
- 2 extension segment 1
- 3 extension segment 2
- 4 network interface module (NIM)
- 5 power distribution module (PDM)
- 6 STB XBE 1100 EOS module
- 7 STB XBE 1300 BOS module
- 8 preferred module
- 9 STB XBE 1000 EOS module
- 10 STB XBE 1200 BOS module
- 11 island bus termination plate

Extension Segments Overview

The STB XCA 100x Island bus extension cable connects two STB island segments. One end of the cable plugs in to the island bus communications output port on the front panel of the EOS module (at the end of one island segment). The other end of the extension cable plugs in to the island bus communications input port on the front panel of the BOS module (at the beginning of the next island segment). The example below shows an STB XBE 1100 EOS and an STB XBE 1300 BOS modules connected via an STB XCA 100x extension cable:

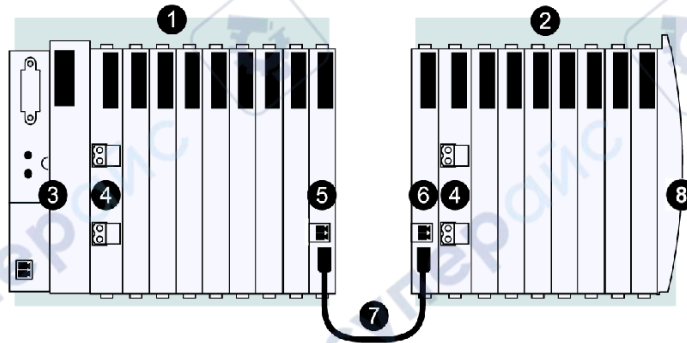

- 1 primary island segment
- 2 extension segment
- 3 network interface module (NIM)
- 4 power distribution module (PDM)
- 5 STB XBE 1100 EOS module
- 6 STB XBE 1300 BOS module
- 7 STB XCA 100x extension cable
- 8 island bus termination plate

Connectors

The STB XBE 1200 and STB XBE 1300 BOS modules can accept 24V DC voltage from a 24V DC power supply connected to its 2-pin power connector, and pass this power to another extension segment. The STB XBE 1100 EOS module can accept 24V DC voltage from a 24V DC power supply connected to its 2-pin power connector, and pass this power to another extension segment, or to a preferred module.

Each module's 2-pin connector can accept either:

- a *screw type* power connector, available in a kit of 10 (model STB XTS 1120)
- a *spring clamp* power connector, available in a kit of 10 (model STB XTS 2120)

Each entry slot accepts a wire in the range 0.14 to 1.5 mm² (28 to 16 AWG). Each connector has a 3.8 mm (0.15 in) pitch between the entry slots.

We recommend that you strip at least 9 mm from the wire's jacket to make the connection.

Island Bus Extension Cables

If your island configuration includes extension segments, the separate elements need to be connected with special Advantys STB bus extension cables. These bus extension cables are available in five lengths:

Model	Cable Length
STB XCA 1001	0.3 m (1 ft)
STB XCA 1002	1.0 m (3.3 ft)
STB XCA 1003	4.5 m (14.8 ft)
STB XCA 1004	10.0 m (32.8 ft)
STB XCA 1006	14.0 m (45.9 ft)

Each cable has IEEE 1394-style connectors on each end. The cable will transmit the following signals:

- island bus communications between the extension I/O and the NIM
- the island bus address line
- the return signal

The cable does not transmit the 5 VDC logic signal to the next segment or preferred device.

An Advantys STB bus extension cable may be run:

- from an EOS module at the end of one segment to a BOS module at the beginning of an extension segment

NOTE: Do not use a STB XCA cable to make a connection to a CANopen device. The cable that connects standard CANopen devices to the island should meet the recommendations defined in CiA specification DR303-1. Cable with a resistance of 70 mΩ/m and a cross section of 0.25 0.34 mm is recommended.

A preferred module bus extension cable may be run:

- from the STB XBE 1100 EOS module at the end of one segment to a preferred module
- from one preferred module to another preferred module
- from a preferred module to the STB XBE 1300 BOS module at the beginning of an extension segment

NOTE: For cables relative to preferred modules, see the specific preferred module documentation.

How to Extend the Island Bus

Use the following procedure to extend the island bus from one end of segment (EOS) module to the next beginning of segment (BOS) module:

1	Make sure that the matched STB XBE 1000 or STB XBE 1100) module is in the last (right-most) position in the previous segment.
2	Install the matched STB XBE 1200 or STB XBE 1300 BOS module (in an STB XBA 2300 base) in the first position in the extension segment.
3	Build the rest of your segment, starting with the appropriate PDM (in an STB XBA 2200 base) next to the BOS module.
4	Connect the EOS module in the previous segment to the matched STB XBE 1200 or STB XBE 1300 BOS module in the extension segment with a length of an island bus extension cable. Make sure the connectors are seated firmly into their respective receptacles.
5	Connect the BOS module to your source power supply. In general, we recommend using separate supplies for the logic power to each BOS module in the extension segment with a length of the appropriate island bus extension cable. Make sure the connectors are seated firmly into their respective receptacles.

Installing a Preferred Module Extension

Preliminary Considerations

When you use preferred modules on an island, you need to create the island configuration using the STB SPU 1000 Advantys configuration software, then download it to the physical island.

Preferred Module Requirements

When joining a preferred module to island bus segments, it is important to note that only paired end of segment (EOS) and beginning of segment (BOS) modules work in conjunction with one another.

The following EOS and BOS modules are used exclusively with one another when connected to a preferred module:

EOS Module	BOS Module
STB XBE 1100	STB XBE 1300

NOTE: Power for the preferred module must be supplied in accordance with the manufacturer's specifications.

Select a Preferred Module in the Configuration Software

The Advantys configuration software maintains the device profiles of all the preferred modules that are currently available. A list of preferred modules appears in the catalog browser, which appears by default on the right side of the workspace display when you open an island file.

NOTE: If you want to configure a preferred module that does not appear in the catalog browser, you need to update the software with the latest catalog. The latest version of the catalog is always available on the Advantys website, which can be downloaded from the Advantys page on the Schneider Automation website at www.schneiderautomation.com.

Before you select a preferred module from the catalog browser and place in the island configuration, configure the NIM and all the I/O modules that precede the preferred module on the island bus. The first preferred module on an island bus must be immediately preceded by a segment of STB I/O modules that has an STB XBE 1100EOS module at the end of the previous island segment.

Preferred Module Connections

Each preferred module is equipped with connectors, one to receive the island bus signals and the other to pass them on to the next module in the series. A preferred module can be equipped with 120 Ω termination, which can be enabled in the event that the preferred module is the last device on the island bus, or it can be terminated with an island bus terminator.

Preferred Module Segments Overview

The island can be extended with preferred modules between the previous STB XBE 1100 EOS module and the next STB XBE 1300 beginning of segment (BOS) module, or to an island bus terminator. The example below shows a preferred module connected to the STB XBE 1100 EOS and STB XBE 1300 BOS modules via preferred module extension cables:

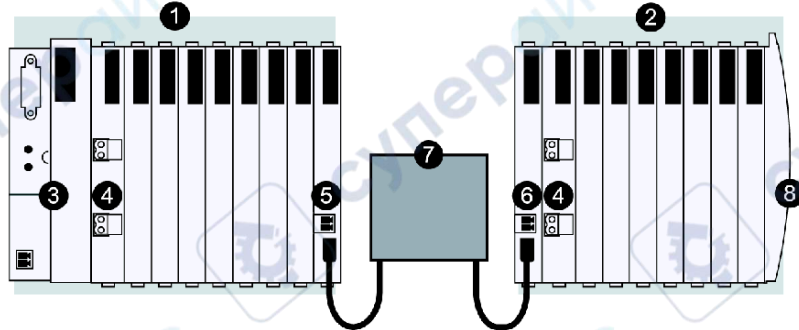

- 1 primary island segment
- 2 extension segment
- 3 network interface module (NIM)
- 4 power distribution module (PDM)
- 5 STB XBE 1100 EOS module
- 6 STB XBE 1300 BOS module
- 7 preferred module
- 8 island bus termination plate

NOTE: As the figure shows, you must install a PDM module to the right of the BOS module for each island bus extension segment.

NOTE: For cables relative to preferred modules, see the specific preferred module documentation.

The example below shows a preferred module connected to the STB XBE 1100 EOS module via a preferred module extension cable and to an island bus terminator:

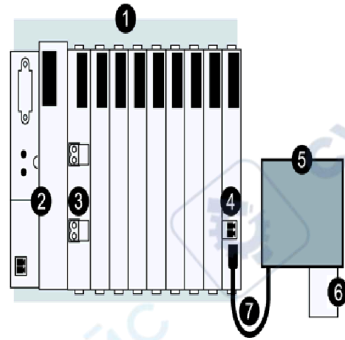

- 1 primary island segment
- 2 network interface module (NIM)
- 3 power distribution module (PDM)
- 4 STB XBE 1100 EOS module
- 5 preferred module
- 6 island bus terminator
- 7 preferred module extension cable

The illustration below shows, preferred modules chained together in series along the island bus, connected by preferred module extension cables.

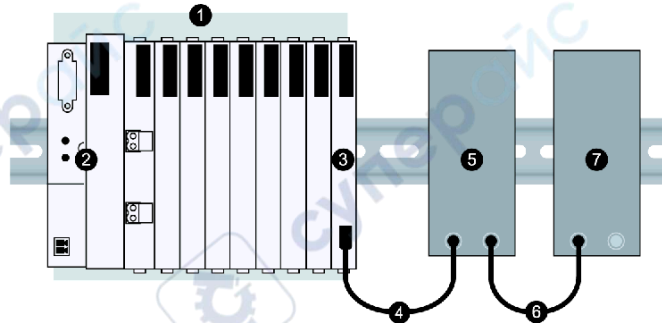

- 1 The primary segment
- 2 The NIM
- 3 An STB XBE 1100 EOS bus extension module
- 4 preferred module extension cable
- 5 The first preferred module
- 6 preferred module extension cable
- 7 The second preferred module, which terminates the island bus with a built-in 120 Ω resistor, or an island buster terminator (not shown).

How to Extend the Island with Preferred Modules

Use the following procedure to extend the island bus with a preferred module:

1	Make sure that the STB XBE 1100 EOS module is in the last (right-most) position in the previous island segment.
2	Connect the EOS module in the previous segment to the preferred module input device with a length of a preferred module extension cable. Make sure the connectors are seated firmly into their respective receptacles.
3	Connect any additional preferred modules to the right of the first preferred module. Refer to the preferred module manual for detailed installation instructions.
4	If you are not extending the island, go to step 8.
5	Install the STB XBE 1300 BOS module (in an STB XBA 2300 base) in the first position in the extension segment.
6	Build the rest of your segment, starting with the appropriate PDM (in an STB XBA 2200 base) next to the BOS module.
7	Connect the BOS module to your source power supply. In general, we recommend using separate supplies for the logic power to each BOS module in the extension segment with a length of the appropriate island bus extension cable. Make sure the connectors are seated firmly into their respective receptacles.
8	Terminate the last segment or the last module on the island bus with a 120 Ω terminator resistor.

Power Requirements

A preferred module does not receive logic power or field power from the island bus. It requires its own power supply and power source.

Installing an CANopen Device Extension

Standard CANopen Devices

An island bus can support standard CANopen devices as well as Advantys STB I/O modules and preferred modules. A maximum of 12 standard CANopen devices can be added to an island. They count as part of the 32-module system limit.

Standard CANopen devices must be added to the end of the island bus (after the last segment). The last segment on the island must end with an STB XBE 2100 CANopen extension module (in a STB XBA 2000 base) followed by an STB XMP 1100 termination plate. The CANopen extension module passes only the CAN H and CAN L communication signals from the last segment to the standard CANopen device/s. Standard CANopen devices cannot be auto-addressed on the island bus.

The CANopen extension module has a 5-pin standard open style receptacle that connects to your supplied extension cable:

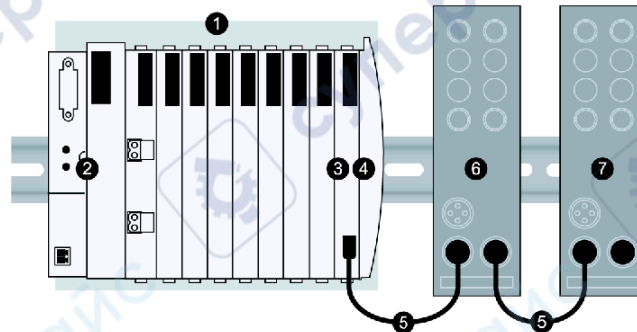

- 1 The primary segment
- 2 The NIM
- 3 An STB XBE 2100 CANopen extension module
- 4 The STB XMP 1100 termination plate
- 5 User supplied cable
- 6 Standard CANopen device
- 7 The last standard CANopen device, with 120 Ω termination applied

The last CANopen device must be terminated with a 120 Ω resistor. This is usually a switch located on the standard CANopen device itself or it may need to be hard wired in.

CANopen Device Requirements

In order to be recognized as a valid island module by the Advantys configuration software, the profile of the standard CANopen device must appear in the Advantys configuration software—i.e., it must appear in the catalog browser in the software. You can drag and drop standard CANopen devices from the catalog browser into the logical island configuration similarly to regular STB I/O modules, but they must be placed at the end of the island bus and they must be preceded by an STB XBE 2100 CANopen extension module in the last position of the last segment on the island bus right before the terminator plate.

If you want to use a standard CANopen device in an Advantys STB island and its device profile does not appear in the Advantys configuration software, contact your local Schneider Electric representative. Schneider Electric is able to integrate standard CANopen devices into the STB catalog when those devices meet the following criteria:

- they conform to the CANopen V4.0 standard (they must support heartbeat and error control)
- they must operate at 500 kbaud
- they must have predefined PDOs with predefined default mappings

NOTE: Make sure that you follow vendor instructions when you install, configure and operate standard CANopen devices on an Advantys STB island.

NOTE: When you use a CANopen extension, make sure that you do not auto-configure the island. Standard CANopen devices are not recognized in an auto-configured system. Auto-configuration also resets the baud rate to 800 kbaud, and an island bus with a CANopen extension must operate at 500 kbaud.

CANopen Extension Cable Requirements

The cable between the STB XBE 2100 extension module and a standard CANopen device, or between two CANopen extension devices, must meet the recommendations defined in CiA specification DR303-1. Cable with a resistance of 70 mW/m and a cross section of 0.25 ... 0.34 mm is recommended.

NOTE: A CANopen extension on an island bus must be separately terminated at the beginning and at the end. The STB XBE 2100 CANopen extension module has built-in termination for the beginning of the CANopen extension. You must provide termination at the last CANopen device on the extension. Make sure that you connect your cables in a way that assures that the STB XBE 2100 is always the first module on the extension sub-net.



Grounding Considerations

4

Summary

Some considerations and techniques for grounding the Advantys STB island bus operation safe are presented.

What's in this Chapter?

This chapter contains the following topics:

Topic	Page
Power Isolation Requirements on the Island Bus	122
Voltage Cut-out Switching	123
The Protective Earth Connection	124
The Functional Earth Connection	126
EMC Kits	127

Power Isolation Requirements on the Island Bus

Isolation Requirements

The power source for the NIM and any auxiliary power supply or BOS modules must be galvanically isolated. Isolation is not provided by the NIM or BOS modules themselves.

External Power Supply Requirement

Any external 24 VDC power supply that provides the source power to the island bus must be SELV-rated. The input side must be galvanically isolated from the output side.

This SELV requirement applies to all 24 VDC power supplies supporting both logic power and field power—i.e., supplies that provide 24 VDC to the NIM or to an STB PDT 3100 power distribution module.

CAUTION

IMPROPER GALVANIC ISOLATION

The power components are not galvanically isolated. They are intended for use only in systems designed to provide SELV isolation between the supply inputs or outputs and the load devices or system power bus.

- You must use SELV-rated supplies to provide 24 VDC source power to the NIM and any BOS or auxiliary power supply modules in your system
- If you are using a relay module with a contact voltage above 130 VAC, do not use a common external 24 VDC power supply for the PDM supporting that module and the logic power in the NIM, auxiliary power supplies, or BOS modules
- Above 130 VAC, the relay module defeats the double insulation provided by a SELV-rated power supply

Failure to follow these instructions can result in injury or equipment damage.

Voltage Cut-out Switching

Advantage of the Power Distribution Method

One of the key features of Advantys STB island is the separate distribution of field power to input and output modules. A standard PDM distributes field power to the input modules via a sensor bus and independently distributes field power to the output modules over an actuator bus.

With a simple relay switch installed between the source power supply and the actuator bus connection on the standard PDM, you can test your application program with live inputs while the outputs are disabled.

Here is an example of this relay switch setup:

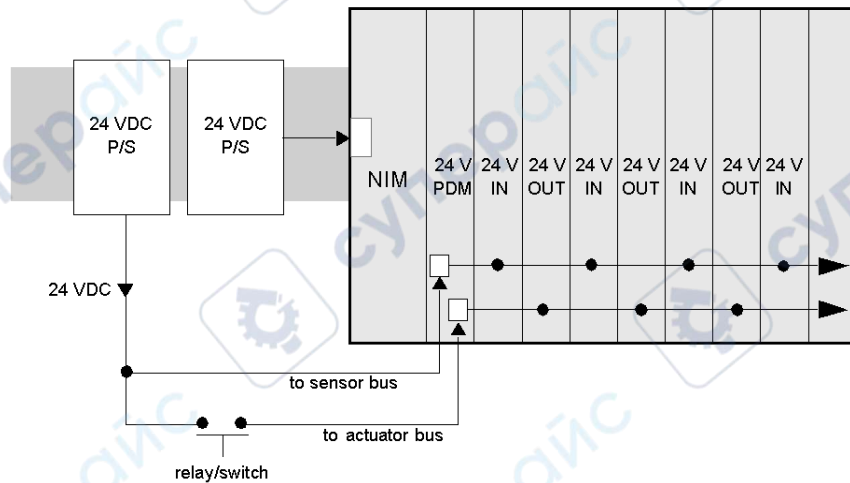

Recommended Safety Relays

Schneider recommends their Preventa line of relays. For a complete selection contact your Schneider representative and ask for catalog DHMED 198043 XX.

The Protective Earth Connection

PE Contact for the Island

One of the key functions of a PDM, in addition to distributing sensor and actuator power to the I/O modules, is the provision of protective earth (PE) to the island. On the bottom of each STB XBA 2200 PDM base is a captive screw in a plastic block. By tightening this captive screw, you can make a PE contact with the island bus. Every PDM base on the island bus should make PE contact.

How PE Contact Is Made

PE is brought to the island by a heavy-duty cross-sectional wire, usually a copper braided cable, 6 mm² or larger. The wire needs to be tied to a single grounding point. The ground conductor connects to the bottom of the each PDM base and is secured by the PE captive screw.

Local electrical codes take precedence over our PE wiring recommendations.

Handling Multiple PE Connections

It is possible that more than one PDM will be used on an island. Each PDM base on the island will receive a ground conductor and distribute PE as described above.

NOTE: Tie the PE lines from more than one PDM to a single PE ground point in a star configuration. This will minimize ground loops and excessive current from being created in PE lines.

This illustration shows separate PE connections tied to a single PE ground:

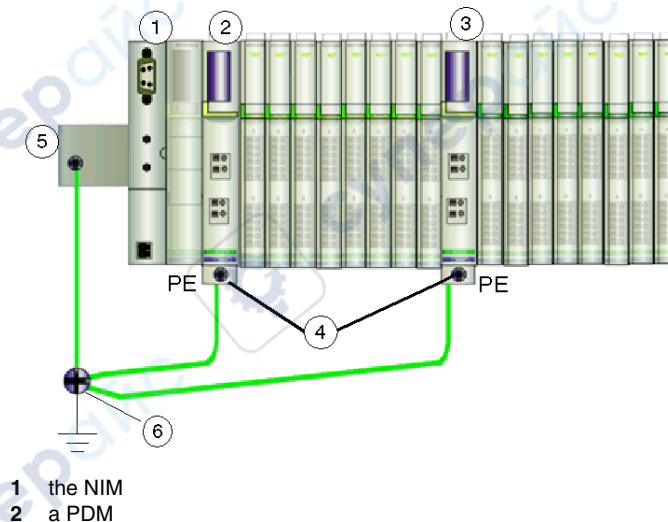

- 3 another PDM
- 4 captive screws for the PE connections
- 5 FE connection on the DIN rail
- 6 PE ground point

The Functional Earth Connection

Functional Earth (FE) on the DIN Rail

The DIN rail for your Advantys STB island is considered the functional earth ground (FE) plane for your system. Here EMI and RFI are suppressed. The connection between this ground and your island is made at the contacts on the back of your island's NIM and at the back of the I/O bases. It is essential that this connection be sound.

Rail Mounting Considerations

If you are using 7.5 mm DIN rail, make sure that the region along the rail where the island bases will be installed does not have any screw heads on it. The base units may not make proper contact with the rail if there are screw heads behind them, and the FE contact may be compromised. A 7.5 mm DIN rail can support vibration conditions up to 3 g.

For high vibration environments (up to 5 g), the rail needs to be fastened to the mounting surface along areas where the island modules are mounted. You need to use 15 mm DIN rail. The screw heads on 15 mm rail must be sufficiently recessed so that they do not interfere with the base-to-rail FE contacts.

EMC Kits

Overview

EMC kits reduce electromagnetic and radio interference by grounding the shielded cables entering your Advantys I/O modules at close proximity. The cables are stripped, exposing the braided shield, then clamped to an FE grounded bar mounted in front of your island segment. The STB XSP 3000 kit comes with a 1 m grounding bar that can be cut to needed length/s.

There are three reasons to use the EMC kits on an Advantys STB island:

- to make Advantys STB analog I/O modules CE compliant
- to reduce RFI/EMI to the Advantys STB analog modules
- to reduce RFI/EMI to any of your I/O modules

The illustration below is an example of an Advantys STB island segment with an EMC kit making the analog I/O modules CE compliant.

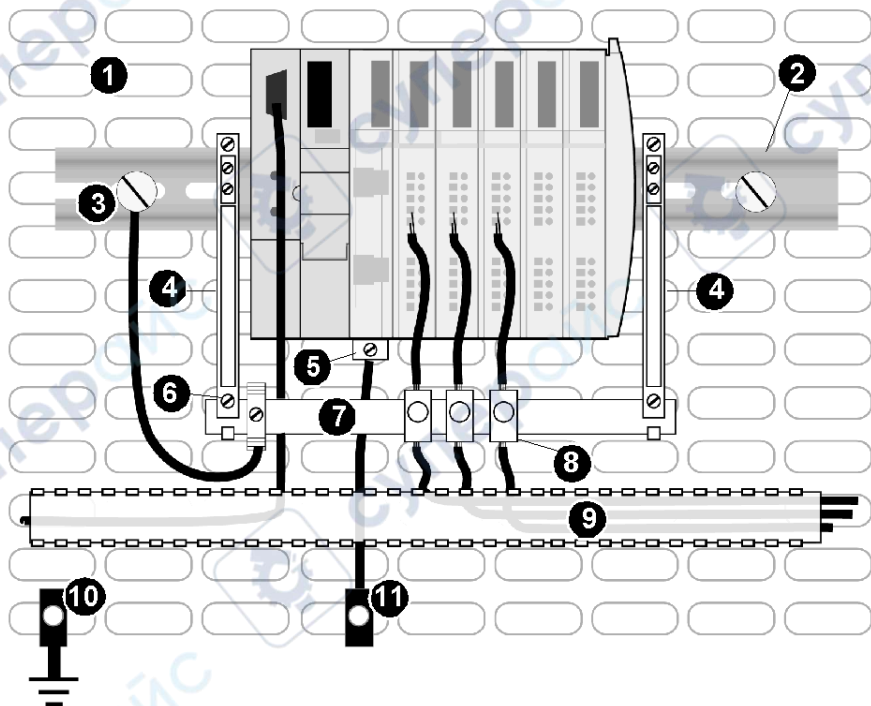



- 1 metal mounting, earth grounded, surface
- 2 the DIN rail attached to metal mounting surface
- 3 functional earth (FE) grounding point
- 4 EMC side brackets

- 5 PDM PE screw)
- 6 EMC FE clamp
- 7 FE grounding bar from an STB XSP 3000 EMC kit, used as a FE point for shielded cables and as a cable stabilizer
- 8 EMC cable clamp
- 9 cable channel
- 10 6 mm² braided cable to plant ground
- 11 protective earth (PE) grounding point (made as close as possible to the I/O))

The Kits

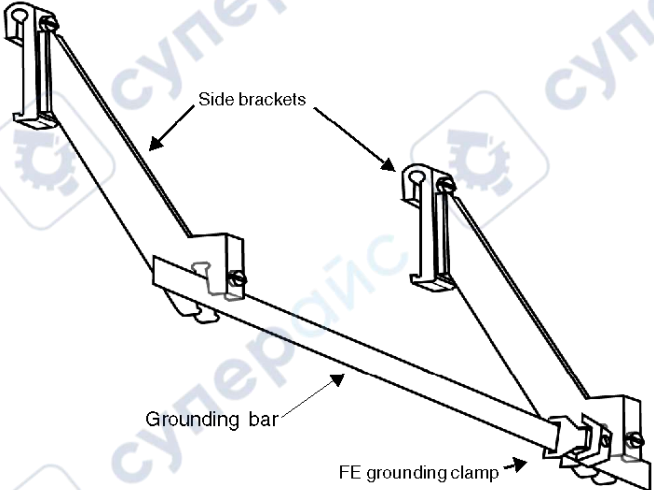
Three kits are provided to ground your shielded cable. To do an initial set up, you need an STB XSP 3000 kit and at least one of the cable clamp kits (STB XSP 3010 or STB XSP 3020). STB XSP 3010 kit comes with ten cable clamps for 1.5 mm to 6.5 mm size cable. STB XSP 3020 kit comes with ten cable clamps for 5 mm to 11 mm size cables.

Kit	Comes with...
STB XSP 3000	two side brackets, one 1 m grounding bar and one FE grounding clamp 

Kit	Comes with...
STB XSP 3010	10 small cable clamps for 1.5mm to 6.5mm cable 
STB XSP 3020	10 medium cable clamps for 5mm to 11mm cable 

STB XSP 3000 Assembly

Use the following procedure to assemble an STB XSP 3000 kit.

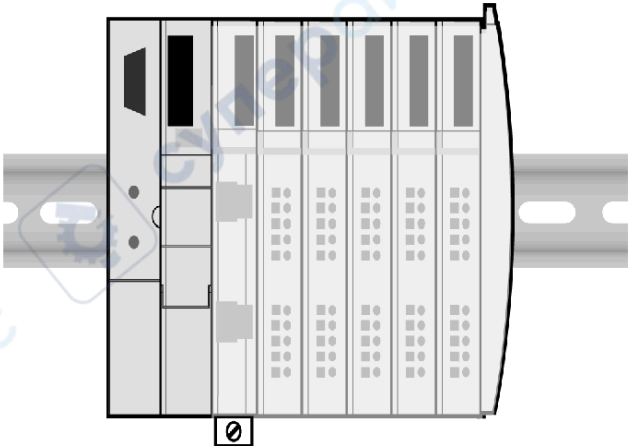
Step	Action
1	Open kit STB XSP 3000 and make sure you have the two side brackets, one grounding bar and one FE grounding clamp. (Refer to the Kits section above).
2	Assemble an Advantys STB island segment. 

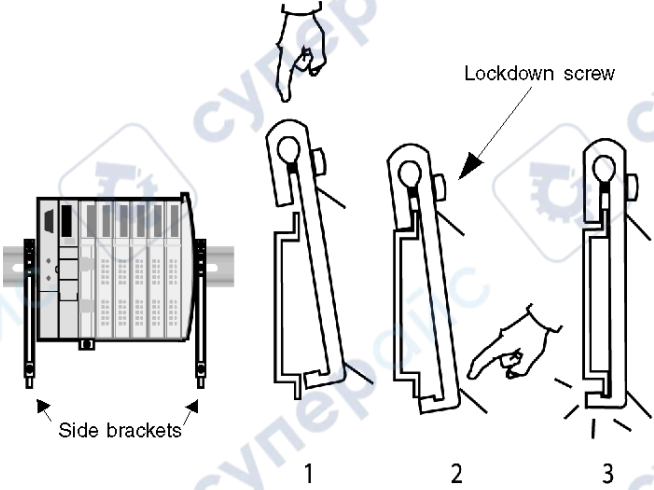
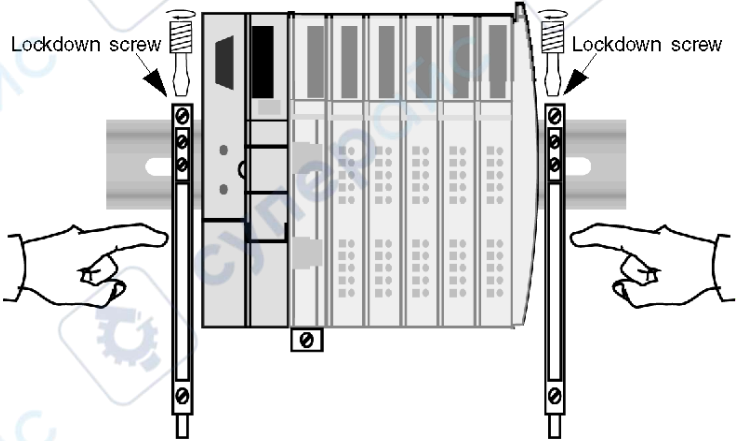
Step	Action
3	<p data-bbox="491 199 1232 280">Loosen the bracket lock down screw located on each side bracket. Attach the side brackets to the DIN rail on both ends of your assembled Advantys STB island segment. They will gently snap into place.</p> 
4	<p data-bbox="491 808 1245 865">Push the side brackets toward both ends of your segment so that they are snug against its walls, and tighten the lock down screws.</p> 

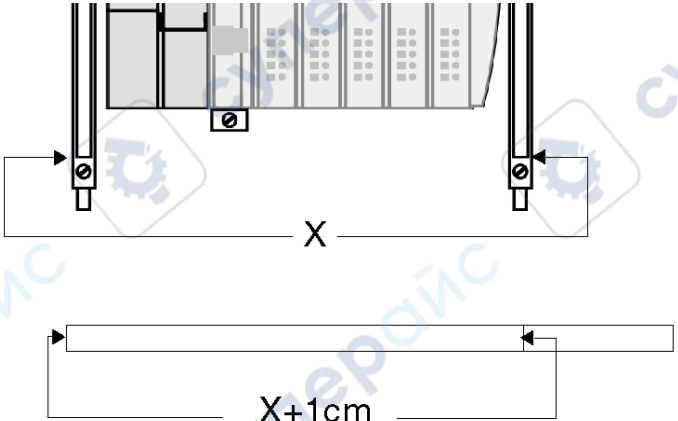
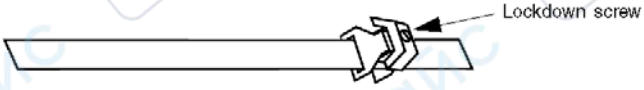
Step	Action
5	<p data-bbox="469 203 1218 305">Determine the grounding bar length by measuring the distance between the outsides of the side bracket/segment assembly and add 1 cm. (this is a general rule for grounding bar length. You can make adjustments to satisfy your particular needs). Cut the bar to length.</p>  <p data-bbox="469 771 1173 820">The grounding bar is originally 1 M long x 18 mm wide x 3 mm thick tinned copper. To order extra grounding bars alone contact a local supplier.</p>
6	<p data-bbox="469 836 1179 885">With the grounding bar cut to length, slide the FE grounding clamp onto the grounding bar and tighten the lock down screw on top of the clamp.</p> 

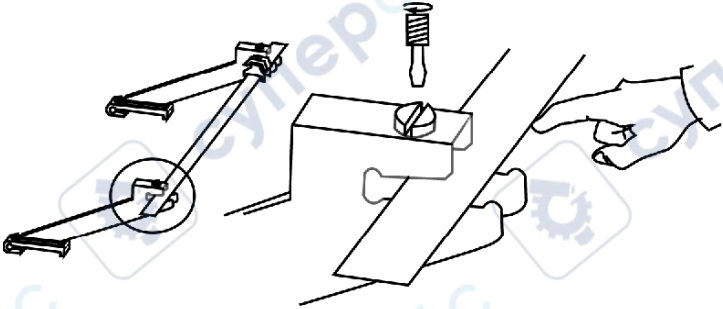
Step	Action
7	<p data-bbox="491 199 1238 248">Attach the grounding bar to the side brackets and tighten the lockdown screws on the side brackets.</p> 
8	<p data-bbox="491 610 1238 659">Ground the FE grounding clamp to your supplied FE ground using flat braided gounding cable.</p>

Clamp and Cable Assembly

The grounding clamps are used to ground the shielding of the stripped cable to the FE grounding bar. The assembly consists of attaching the grounding clamp to the FE grounding bar, stripping the insulation off of the cabling to expose the braided shield underneath, and inserting it into the ground clamp.

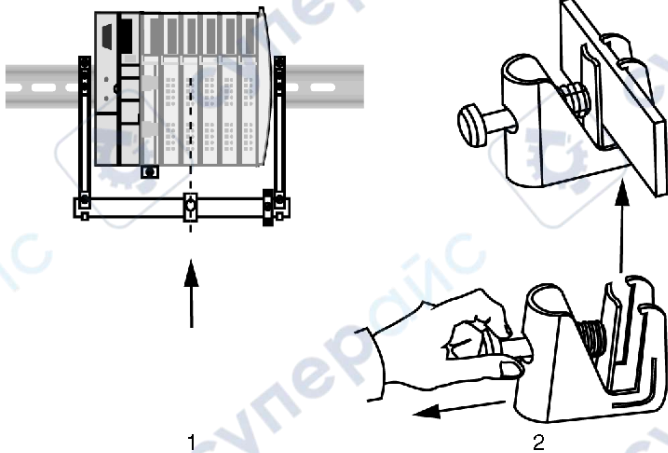
Step	Action
1	<p data-bbox="491 215 1236 293">Position the grounding clamp in front of the module who's cable will be secured by it. On the clamp: pull back on the spring loaded lock down bolt, slip the clamp onto the grounding bar, and release to secure.</p> 

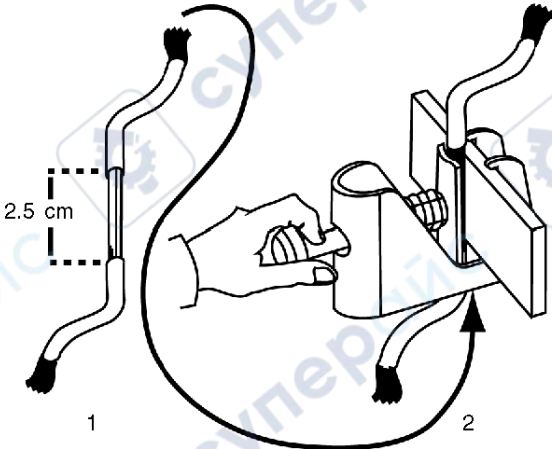
Step	Action
2	<p data-bbox="467 201 1219 305">Strip 2.5 cm of insulation off of your cable to expose the braided shield below. (Be sure the cable on either side of the stripped area is long enough to reach the I/Os and user devices). Pull back on the spring loaded lockdown bolt and slip the cable into the clamp. Release the lockdown bolt.</p>  <p data-bbox="467 800 1219 849">Alternatively, you can clamp your cable to the grounding bar while you attach the cable clamp to the bar.</p>
3	Secure your cable to its I/Os and devices.



Commissioning an Advantys STB Island

5

Commissioning the Island

Once the island hardware has been installed and you are sure that the installation has been properly grounded, you can follow the procedures in this chapter to commission the island as an operational node on your fieldbus network.

What's in this Chapter?

This chapter contains the following topics:

Topic	Page
Making Fieldbus and Power Connections	138
Configuring the Island	142
Changing Baud Rates	145
Hot Swapping Advantys STB I/O Modules	146
Fault Detection and Troubleshooting	154

Making Fieldbus and Power Connections

Overview

The fieldbus and power connections to your island must be made with the power off. The cable and connector types for the fieldbus connection are on your NIM. The connectors do differ on different NIM types. Refer to the manual that came with your particular NIM for detailed information on cabling and connectors.

Fieldbus Connection

The fieldbus connection is made between your fieldbus master and the NIM on your physically completed Advantys island. To make the connection, simply push your fieldbus connector into its matching receptacle and lock it in place.

NIMs are available to support seven different open fieldbus protocols. Here are illustrations of some of the NIM types. The key difference is in their fieldbus connectors.



Power Connections

There are at least two power connections to be made to your island from your source power supply or supplies:

- 24 VDC to the each island segment for logic power
- 24 VDC, 115 VAC, or 230 VAC field power to at each PDM in the island configuration

If you are using a standard PDM on the island bus, you need to use separate field power connection for the sensor bus and the actuator bus. If you are using a low-cost basic PDM, one field power connection is all that is made to each PDM.

Power can be supplied by the same power supply (delivered in parallel) or by independent power supplies. In general, we recommend using separate supplies for the logic power to the NIM and for field power to the PDM(s). The power supplies must be SELV rated. Your design decision should be based on current needs and capabilities. The supplies can be mounted on the same DIN rail or mounted separately. They are generally enclosed in the same EIA rated enclosure that your island is in. To make the connection simply push your power connectors into their matching receptacles.

The DC PDMs are designed with reverse polarity protection. This will help prevent damage to the DC modules and protect them from possible unexpected field operation. However, this is only intended as a temporary protection during commissioning of the island.

Here is an independent power scheme for an Advantys STB island with a standard PDM using two power supplies:

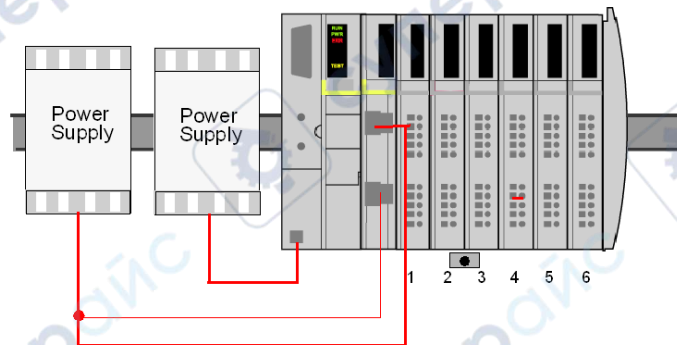

Here is a 24 V parallel power scheme for an Advantys STB island with a standard PDM:

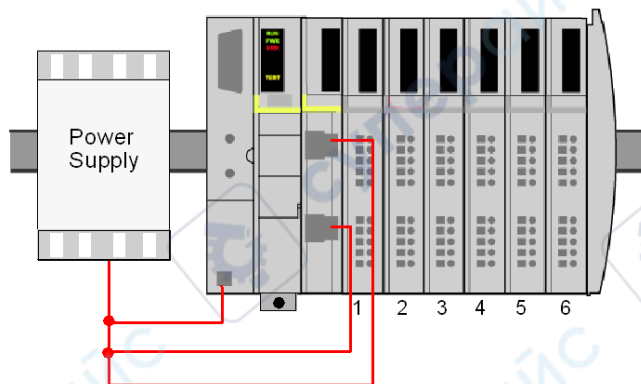

Here is an independent power scheme for an Advantys STB island with a basic PDM using two power supplies:

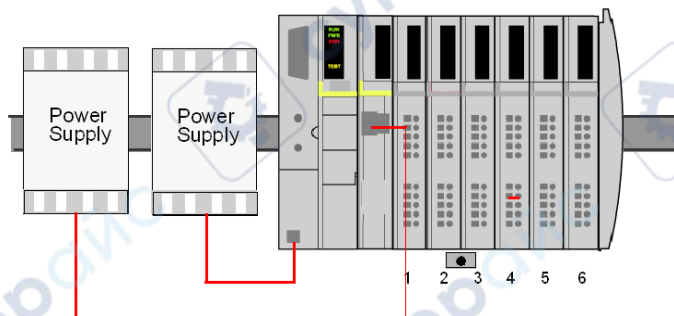

Here is a 24 V parallel power scheme for an Advantys STB island with a basic PDM:

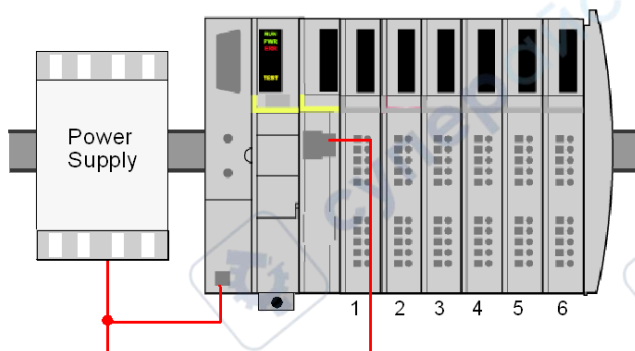

⚠ CAUTION

IMPROPER GALVANIC ISOLATION

The power components are not galvanically isolated. They are intended for use only in systems designed to provide SELV isolation between the supply inputs or outputs and the load devices or system power bus. You must use SELV-rated supplies to provide 24 VDC source power to the NIM.

If you are using a relay module with a contact voltage above 130 VAC, do not use a common external 24 VDC power supply for the PDM supporting that module and the logic power in the NIM, BOS module, or auxiliary power supply. Above 130 VAC, the relay module defeats the double insulation provided by a SELV-rated power supply.

Failure to follow these instructions can result in injury or equipment damage.

Configuring the Island

Summary

There are three ways to configure your Advantys STB I/O:

- Using the I/O default parameters (auto-configuration)
- Using the Advantys configuration software to custom configure the I/O
- Using the I/O configurations stored in a removable memory card inserted into your NIM

To configure your NIM and correctly power up your system read the applications guide that came with your NIM.

Auto-configuration

All Advantys STB I/O modules are default-configured with a set of predefined parameters. This allows your island to be operational as soon as it is powered up and initialized. This quick launch I/O configuration is called auto-configuration. Upon island startup the predefined parameters stored in your I/O modules are automatically read and written by the NIM and stored in Flash memory. As part of the auto-configuration process, the NIM checks each module and confirms that it has been properly connected to the island bus.

Auto-configuration occurs when:

- You power up a new island for the first time
- You push the RST button

Here is a view of the reset button on the NIM:

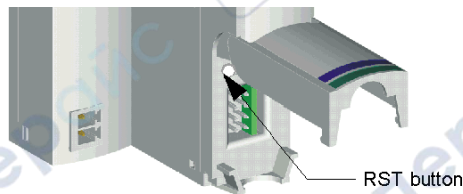

NOTE: Using the Advantys configuration software you can disable the reset button. In this situation pressing the reset button will not affect the existing configuration.

Custom Configuration

NOTE: The following discussion assumes that you are using a standard NIM in your island configuration. The low-cost basic NIMs do not support the Advantys configuration software. They use only a set of fixed nonconfigurable operating parameters.

Custom I/O configuration using the Advantys configuration software is done after your island has been powered up and initialized. Refer to your Advantys configuration software manual for more details.

Here is a picture of the bottom of the NIM showing where you connect your STB XCA 4002 configuration cable to custom configure the I/O using the Advantys configuration software:

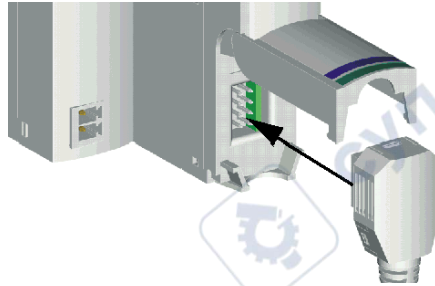

In addition to setting custom parameters for the I/O modules, the Advantys configuration software lets you:

- create, modify and save the logical description of all physical devices used in a project
- monitor, adjust data values, and debug the project in online mode
- see a graphical display of the selected equipment and a hierarchical structure (the workspace browser) representing the equipment hierarchy
- configure reflex actions
- enhance performance of specific modules

NOTE: If the NIM in your island configuration has an Ethernet port, you have the option to configure the island through the Ethernet connection.

Removable Memory Card

NOTE: The following discussion assumes that you are using a standard NIM in your island configuration. The low-cost basic NIMs do not support the removable memory card.

An optional removable memory card (I²C SIM card, part STB XMP 4400) is available with standard NIMs. It lets you store, reuse and distribute custom island bus configurations. This custom configuration can be initially loaded into the memory card using the Advantys configuration software. By simply installing the memory card with your custom configuration into your NIM and then cycling power, you can custom configure an island without using the Advantys configuration software a second time. For detailed information on the removable memory card see your NIM's applications guide.

Here is a picture of the memory card being installed in a NIM. The card is installed by pulling the memory card drawer out of the front of the NIM, inserting the memory card into the drawer and pushing the drawer back into the NIM:

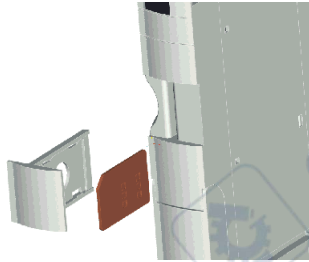

Changing Baud Rates

System Baud Rates

By default, an island bus communicates at 800 kbaud. If you are using a basic NIM on the island bus, this baud rate is a fixed operating parameter that cannot be changed. If you are using a standard NIM in conjunction with the Advantys configuration software, you may change the baud rate to 500 kbaud as described below.

NOTE: If you use standard CANopen devices as part of your island, the island bus must be configured to operate at 500 kbaud.

Changing the Baud Rate

The factory default baud rate is 800 kbaud. If you want to change the baud rate, you need to use the Advantys configuration software.

NOTE: When replacing NIMs in islands that contain STB CPS 2111 power supplies or EOS-BOS combinations, you must power off all units (NIMs, power supplies, and EOS-BOS combinations) on the island. The power off prevents a possible NIM error from occurring when you power up the units. The error takes place when the original and replacement NIM baud rate settings differ. Power cycling the entire island clears the error.

Using the Advantys configuration software, you can change the island's baud rate as follows:

Step	Action	Result
1	From the Island pull-down menu, select Baud Rate Tuning .	A Baud Rate Tuning dialog appears.
2	Use the drop-down list box in the Baud Rate Tuning dialog to select the desired baud rate (either 800 kbaud or 500 kbaud).	
3a	Click OK .	If you did not change the baud rate value in the Baud Rate Tuning dialog, the old baud rate remains in effect. If you did change the baud rate value in the dialog, a message appears letting you know that your system performance may be affected by changing the baud rate.
3b	If the message box appears and you accept the possible change in system performance, push OK .	The new baud rate for the island bus is now set to the selected value.

Hot Swapping Advantys STB I/O Modules

Hot Swapping

Hot swapping is the ability to pull an I/O module from its base and then replace it while the island is under power without disrupting the normal operations on the island. When the module is returned to its base or replaced with another module with the same model number, it starts to operate again on the island.

DANGER

EXPLOSION HAZARD

Never attempt to hot swap any module that is located in an explosive environment. Do not separate, assemble, or disconnect/connect equipment unless power has been switched off or the area is known to be non-hazardous.

Failure to follow these instructions will result in death or serious injury.

NOTE: When you use a low-cost basic NIM on the island bus, hot swapping is not supported. If you remove an I/O module from its base and then replace it, that module will not start to operate until after you cycle power on the island.

NOTE: Hot swapping is not supported when there is only one I/O module on the island bus. Likewise, with multiple I/O modules, if you remove all of them before replacing one, the NIM will enter fatal error. You must cycle power on the island to recover from the error.

With a Standard NIM

When you use a standard NIM on the island bus, you can hot swap most I/O modules from their bases.

DANGER

ELECTRIC SHOCK HAZARD

When removing or inserting a module into a base on an island that has field power applied, use only your hands. Do not use metal tools, they can come in contact with dangerous live voltage. Also, remove any plugs that are attached to the module before removing the module from its base.

Failure to follow these instructions will result in death or serious injury.

NOTE: If any of your modules are being used to provide operating power to a large inductive load (at or near a maximum of 0.5 H), make sure that you turn any field devices OFF before removing the field power connector from the modules. The output channel on the modules may be damaged if you remove the connector while the field devices are ON.

Hot Swapping Modules with the Same Model Number

If an I/O module is removed from its base and then replaced by another module with the same model number, the standard NIM will auto-configure and auto-address the new module with values that are identical to those of the previous module. The NIM automatically puts the new module in operation.

For example, say you have an island that comprises a standard NIM, a PDM and six I/O modules. All these I/O modules are *optional*—i.e., none have been configured as mandatory.

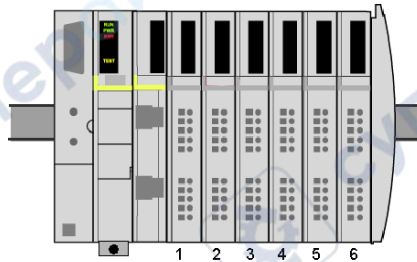

Suppose you have an STB DDO 3230 output module in address location 4, and it is malfunctioning. When you remove the module from its base, as shown below, the remaining five I/O modules in locations 1, 2, 3, 5 and 6 will continue to operate.

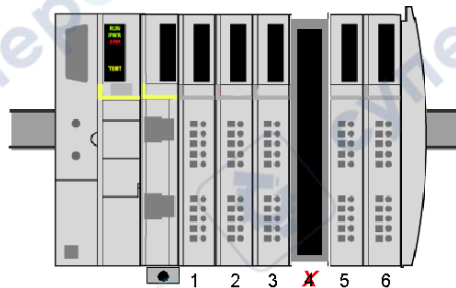

If you then place a new STB DDO 3230 output module in location 4, the NIM will recognize its device profile, configure it like the old module, and start supporting all six I/O modules the same as it did before the hot swap.

If a power cycle is performed while the module is missing, only the modules to the left of the missing one will be operational. You must cycle power on the island to recover from the error.

Do Not Hot Swap Modules with Different Model Numbers

If an I/O module is removed from its base and then replaced by a module with a different model number, the remaining modules on the island will continue to operate but the new module will not be operational. The green RDY LED on the new module will blink to indicate that it is in pre-operational mode, and the ERR LED on the NIM will indicate that a device mismatch has been detected.

If you choose to keep the module with a different model number in the base, you will have to reconfigure the system to make it operational.

Do Not Reset the Island Bus While a Module Is Removed

NOTE: The following information describes the behavior of the island if you reconfigure it using the RST push button when a module is missing. It is presented for illustrative purposes only. Reconfiguring an island on a running installation will most likely require a corresponding change to the bus master configuration.

If you push the RST button on the NIM while an I/O module is missing from the island bus, the island will re-configure, and only the modules to the left of the missing one will be operational.

For example, if an I/O module is removed from address location 4 of the island bus as shown below:

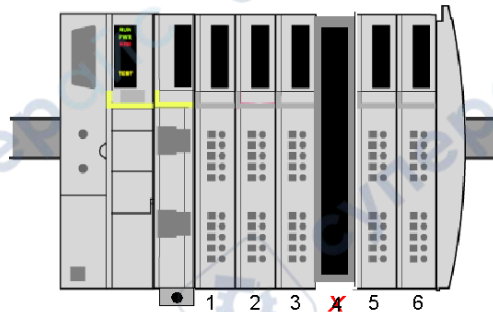

and then the RST button on the NIM is pushed, the modules in locations 1, 2 and 3 will remain operational, and the modules to the right of the empty location will not be detected.

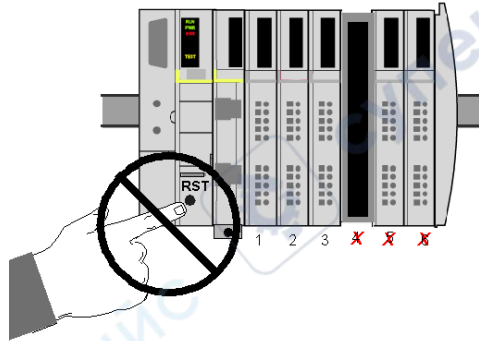

The green RDY LED on the modules in address locations 5 and 6 will flicker to indicate that they have not been auto-addressed.

NOTE: Using the Advantys configuration software you can disable the reset button. In this situation pressing the reset button will not effect the configuration. If the reset button is active, pressing it will erase the existing configuration.

Mandatory Module Considerations

If the island contains any I/O modules that have been configured as mandatory, you need to be aware of how the island will behave in the event of a reset or power cycle.

Suppose you have an island that comprises a NIM, a PDM and six I/O modules. The modules at address locations 1, 2, 3, 5 and 6 are optional, and the module at location 4 is mandatory.

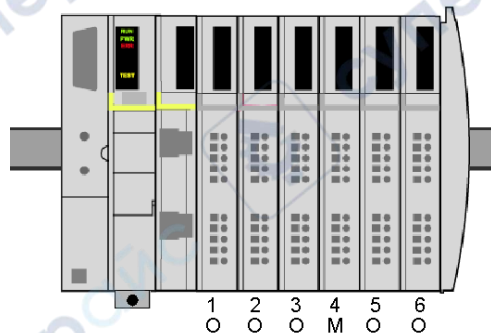

O optional

M mandatory

If the mandatory module in location 4 is removed, all the modules will go into pre-operational mode and the island will not function. However, there are also some special circumstances involving the hot swapping of optional modules when a mandatory module is present on the island.

If we remove an optional module that resides to the right of any and all mandatory modules, as shown below,

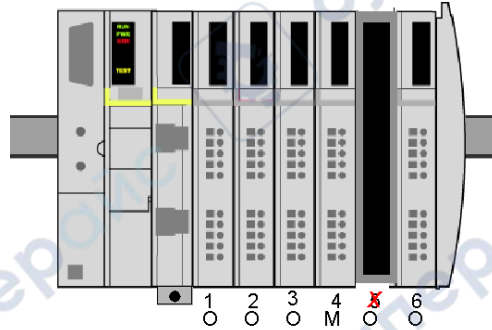

the island will behave the same way as it would if all the modules were optional—all of the existing modules would continue to be operational. Now, If the reset button is pushed your configuration will be erased and modules 1 through 4 will be default configured—all optional. If you power cycle instead of pushing the reset button, all the existing modules, except for the module in position 6, will be operational again and module 4 will continue to be configured as mandatory:

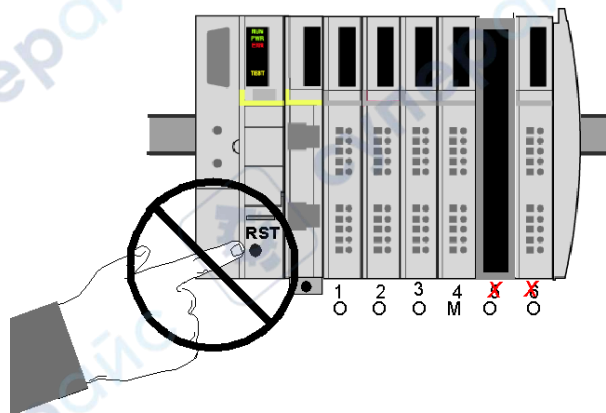

The island behavior changes, however, if an optional module to the left of a mandatory module is removed.

Suppose that the module in location 4 is mandatory and the optional module in location 2 is removed from its base, as shown below.

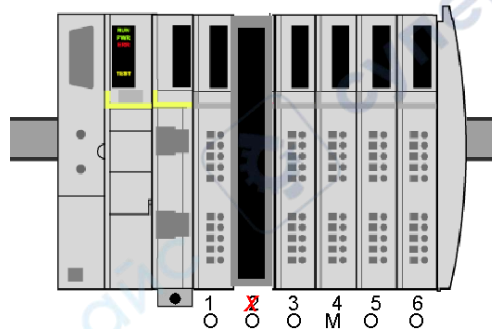

Again, the island will behave the same way as it would if all the modules were optional—all of the existing modules would continue to be operational. However, if you push the RST button while the module is removed the current configuration will be erased and only the module in location 1 will be operational.

If you power cycle, instead of pushing the reset button, the island will not recognize the modules to the right of the missing module in location 2. Since one of the modules that is not recognized is the mandatory module in location 4, the entire island will go into pre-operational mode and will not function.

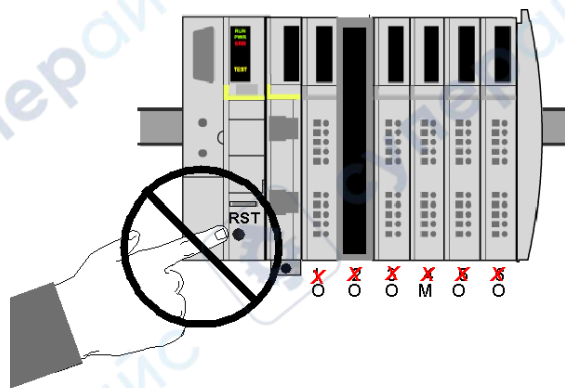

Modules that Can't be Hot Swapped

 **DANGER**

EXPLOSION HAZARD

Never attempt to hot swap any module that is located in an explosive environment.

Do not separate, assemble, or disconnect/connect equipment unless power has been switched off or the area is known to be non-hazardous.

Failure to follow these instructions will result in death or serious injury.

Advantys STB modules that cannot be hot swapped under any circumstances include:

Modules that Can't Be Hot Swapped	Reasons
Any module located in an explosive environment <i>(see page 35)</i>	For safety reasons. Removal of a module could result in an explosion. (see Danger notice, above).
The NIM	A NIM must be present and operational to manage communications on the island bus and to supply logic power across the primary segment of the island. Also, the design of the NIMs is such that the module cannot be removed from its base.
Advantys STB I/O modules that have been designated <i>Mandatory</i> in the Advantys configuration software	By definition, when a mandatory I/O module is removed from the island, all the other I/O modules will go to their fallback states, and the island will not be operational. If a mandatory I/O module is swapped out of the island bus, normal bus operations will be disrupted.
PDMs	PDMs must be present and operational in order for field power and PE to be available to a voltage group of I/O modules on the island bus.
Auxiliary power supply	When an auxiliary power supply is operating in a segment, it provides logic power to I/O modules located to its right in that segment. If an auxiliary power supply is removed, all modules to its right in the segment (including an EOS module) stop functioning; any extension segments to the right of the removed auxiliary power supply lose communication with the NIM.
BOS modules	A BOS module must be present and operational in an extension segment to extend island bus communications.

Modules that Can't Be Hot Swapped	Reasons
EOS modules	An EOS module must be present and operational at the end of an island segment whenever you need to extend island communications to any extension segments or preferred devices.
CANopen extension module	A CANopen extension module must be present and operational at the end of an island segment whenever you need to extend island communications to any standard CANopen device.

Maximum Insertion/Removal Cycles

The bases are designed to withstand up to 50 module insertion/removal cycles.

NOTE: If modules are inserted and removed from a base more than 50 times, the integrity of the module-to-base contacts cannot be guaranteed. Be sure the history of your modules is known before hot swapping them.

Fault Detection and Troubleshooting

Summary

NOTE: The following discussion applies to islands that use a standard NIM. The low-cost basic NIM does not support a connection to the Advantys configuration software or to an HMI panel. The basic NIMs do have a limited LED-based indicator panel.

By connecting to a standard NIM via its CFG port and by viewing the LED readouts on your NIM and I/O modules, you can detect and troubleshoot faults on an Advantys STB island.

Your particular fieldbus master has its own fault detection abilities as well. Refer to the appropriate user guide (*see page 77*).

CFG port

The CFG port on a standard NIM is the connection point to the island bus for either an Advantys configuration software panel or an HMI panel.

Physical Description

The CFG interface is a front-accessible RS-232 interface located behind a hinged flap on the bottom front of the NIM:

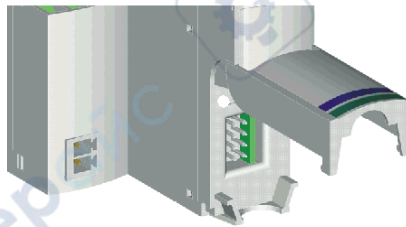

The port uses a male eight-pin HE-13 connector.

Port Parameters

The CFG port supports the following communication parameters:

Parameter	Valid Values (see Note 1)	Factory Default Settings
bit rate (baud)	2400/4800/ 9600/9200/ 38400/ 57600	9600
data bits	7/8	8
stop bits	1/2	1
parity	none/odd/even	even

Parameter	Valid Values (see Note 1)	Factory Default Settings
protocol	Modbus RTU or Modbus ASCII	Modbus RTU
Note1 To modify the default baud or communication mode parameter, you must use the Advantys configuration software.		

Connections

An STB XCA 4002 programming cable must be used to connect the computer running the Advantys configuration software or a HMI panel capable of running your fieldbus protocol to the NIM via the CFG port.

The following table describes the specifications for the STB XCA 4002 programming cable:

Parameter	Description
model	STB XCA 4002
function	connection to device running configuration software
	connection to HMI panel
communications protocol	Modbus (either RTU or ASCII mode)
cable length	2 m (6.23 ft)
cable connectors	eight-receptacle HE-13 (female)
	nine-receptacle SUB-D (female)
cable type	multiconductor

LED Indicators

LEDs on your NIM give you a visual indication of the operational status of the island bus on your particular network. The LED array is located at the top of the NIM's front panel:

Description

The illustration shows a typical LED array on a standard NIM:

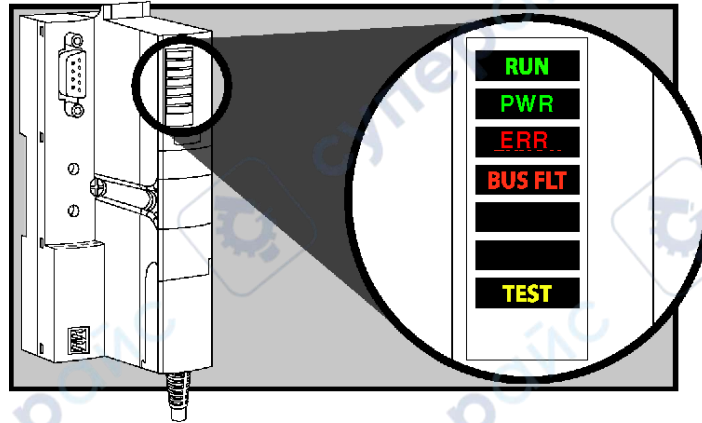

NOTE: The low-cost basic NIMs do not have a yellow TEST LED.

Use the condition table below to look up what your LED array indicates.

LED Condition Table

The table that follows describes the island bus condition(s) communicated by the LEDs, and the colors and blink patterns used to indicate each condition. As you refer to the table, keep in mind the following:

- It is assumed that the *PWR* LED is on continuously, indicating that the NIM is receiving adequate power. If the *PWR* LED is off, logic power to the NIM is off or insufficient.
- Individual blinks are approximately 200 ms. There is a one-second interval between blink sequences. Please note the following:
 - blinking—blinks steadily, alternating between 200 ms on and 200 ms off.
 - blink 1—blinks once (200 ms), then 1 second off.
 - blink 2—blinks twice (200 ms on, 200 ms off, 200 ms on), then one second off.
 - blink *N*—blinks *N* (some number of) times, then one second off.
- If the *TEST* LED (for a standard NIM only) is on, either the Advantys configuration software or an HMI panel is the master of the island bus. If the *TEST* LED is off, the fieldbus master has control of the island bus.

Use the following table to help troubleshoot your system:

RUN (green)	ERR (red)	TEST (yellow)	Meaning
blink: 2	blink: 2	blink: 2	The island bus is powering up (self test in progress).
off	off	off	The island bus is initializing but is not started or there is no power present.
blink: 1	off	off	The island bus has been put in the pre-operational state by the RST button and is not started.
		blink: 3	The NIM is reading the contents of the removable memory card. (Not provided in basic NIMs.)
		on	The NIM is overwriting its Flash memory with the card's configuration data (see 1). (Not provided in basic NIMs.)
off	blink: 8	off	The contents of the removable memory card is invalid. (Not provided in basic NIMs.)
blinking (steady)	off	off	The NIM is configuring or auto-configuring the island bus, which is not started.
blink: 3	off	off	Initialization is complete, the island bus is configured, the configuration matches—the island bus is not started.
		on	Auto-configuration data is being written to Flash memory (see 1).
off	blink: 6	off	The NIM detects no I/O modules on the island bus.
blink: 3	blink: 3	off	Configuration mismatch—non-mandatory or unexpected modules in the configuration do not match; the island bus is not started.
blink: 3	blink: 2	off	Configuration mismatch—at least one mandatory module does not match; the island bus is not started. (Not provided in basic NIMs.)
off	blink: 2	off	Assignment error—the NIM has detected a module assignment error; the island bus is not started.
	blink: 5		Internal triggering protocol error.

RUN (green)	ERR (red)	TEST (yellow)	Meaning
off	blinking (steady)	off	Fatal error. Because of the severity of the error, no further communications with the island bus are possible and the NIM stops the island. The following are fatal errors: <ul style="list-style-type: none"> ● significant internal error ● module-ID error ● auto-addressing failure ● mandatory module configuration error ● process image error ● auto-configuration/configuration error ● island bus management error ● receive/transmit queue software overrun error
on	off	off	The island bus is operational.
on	blink: 3	off	At least one standard module does not match—the island bus is operational with a configuration mismatch.
on	blink: 2	off	Serious configuration mismatch—the island bus is now in pre-operational mode because of one or more mismatched mandatory modules.
blink: 4	off	off	The island bus is stopped—no further communications with the island bus are possible.
off	on	off	Fatal error—internal failure.
[any]	[any]	on	Test mode is enabled—the configuration software tool or an HMI panel can set outputs and/or application parameters (see 2). (Not provided in basic NIMs.)
<p>1 The TEST LED is on temporarily during the Flash overwrite process.</p> <p>2 The TEST LED is on steadily while the device connected to the CFG port is in control.</p>			

Glossary

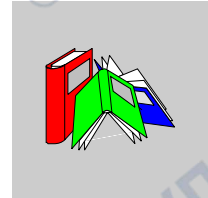

0-9

100Base-T

An adaptation of the IEEE 802.3u (Ethernet) standard, the 100Base-T standard uses twisted-pair wiring with a maximum segment length of 100 m (328 ft) and terminates with an RJ-45 connector. A 100Base-T network is a baseband network capable of transmitting data at a maximum speed of 100 Mbit/s. "Fast Ethernet" is another name for 100Base-T, because it is ten times faster than 10Base-T.

10Base-T

An adaptation of the IEEE 802.3 (Ethernet) standard, the 10Base-T standard uses twisted-pair wiring with a maximum segment length of 100 m (328 ft) and terminates with an RJ-45 connector. A 10Base-T network is a baseband network capable of transmitting data at a maximum speed of 10 Mbit/s.

802.3 frame

A frame format, specified in the IEEE 802.3 (Ethernet) standard, in which the header specifies the data packet length.

A

agent

1. SNMP – the SNMP application that runs on a network device.
2. Fipio – a slave device on a network.

analog input

A module that contains circuits that convert analog DC input signals to digital values that can be manipulated by the processor. By implication, these analog inputs are usually direct. That means a data table value directly reflects the analog signal value.

analog output

A module that contains circuits that transmit an analog DC signal proportional to a digital value input to the module from the processor. By implication, these analog outputs are usually direct. That means a data table value directly controls the analog signal value.

application object

In CAN-based networks, application objects represent device-specific functionality, such as the state of input or output data.

ARP

The ARP (address resolution protocol) is the IP network layer protocol, which uses ARP to map an IP address to a MAC (hardware) address.

auto baud

The automatic assignment and detection of a common baud rate as well as the ability of a device on a network to adapt to that rate.

auto-addressing

The assignment of an address to each Island bus I/O module and preferred device.

auto-configuration

The ability of Island modules to operate with predefined default parameters. A configuration of the Island bus based completely on the actual assembly of I/O modules.

B

basic I/O

Low-cost Advantys STB input/output modules that use a fixed set of operating parameters. A basic I/O module cannot be reconfigured with the Advantys Configuration Software and cannot be used in reflex actions.

basic network interface

A low-cost Advantys STB network interface module that supports up to 12 Advantys STB I/O modules. A basic NIM does not support the Advantys Configuration Software, reflex actions, nor the use of an HMI panel.

basic power distribution module

A low-cost Advantys STB PDM that distributes sensor power and actuator power over a single field power bus on the Island. The bus provides a maximum of 4 A total power. A basic PDM requires a 5 A fuse to protect the I/O.

BootP

BootP (bootstrap protocol) is an UDP/IP protocol that allows an internet node to obtain its IP parameters based on its MAC address.

BOS

BOS stands for beginning of segment. When more than 1 segment of I/O modules is used in an Island, an STB XBE 1200 or an STB XBE 1300 BOS module is installed in the first position in each extension segment. Its job is to carry Island bus communications to and generate logic power for the modules in the extension segment. Which BOS module must be selected depends on the module types that shall follow.

bus arbitrator

A master on a Fipio network.

C**CAN**

The CAN (controller area network) protocol (ISO 11898) for serial bus networks is designed for the interconnection of smart devices (from multiple manufacturers) in smart systems for real-time industrial applications. CAN multi-master systems ensure high data integrity through the implementation of broadcast messaging and advanced error mechanisms. Originally developed for use in automobiles, CAN is now used in a variety of industrial automation control environments.

CANopen protocol

An open industry standard protocol used on the internal communication bus. The protocol allows the connection of any enhanced CANopen device to the Island bus.

CI

This abbreviation stands for command interface.

CiA

CiA (CAN in Automation) is a non-profit group of manufacturers and users dedicated to developing and supporting CAN-based higher layer protocols.

CIP

Common Industrial Protocol. Networks that include CIP in the application layer can communicate seamlessly with other CIP-based networks. For example, the implementation of CIP in the application layer of an Ethernet TCP/IP network creates an EtherNet/IP environment. Similarly, CIP in the application layer of a CAN network creates a DeviceNet environment. Devices on an EtherNet/IP network can therefore communicate with devices on a DeviceNet network via CIP bridges or routers.

COB

A COB (communication object) is a unit of transportation (a message) in a CAN-based network. Communication objects indicate a particular functionality in a device. They are specified in the CANopen communication profile.

configuration

The arrangement and interconnection of hardware components within a system and the hardware and software selections that determine the operating characteristics of the system.

CRC

cyclic redundancy check. Messages that implement this error checking mechanism have a CRC field that is calculated by the transmitter according to the message's content. Receiving nodes recalculate the field. Disagreement in the two codes indicates a difference between the transmitted message and the one received.

D

DDXML

Device Description eXtensible Markup Language

device name

A customer-driven, unique logical personal identifier for an Ethernet NIM. A device name (or *role name*) is created when you:

- combine the numeric rotary switch setting with the NIM (for example, STBNIP2212_010), or . . .
- edit the **Device Name** setting in the NIM's embedded web server pages

After the NIM is configured with a valid device name, the DHCP server uses it to identify the island at power up.

DeviceNet protocol

DeviceNet is a low-level, connection-based network that is based on CAN, a serial bus system without a defined application layer. DeviceNet, therefore, defines a layer for the industrial application of CAN.

DHCP

dynamic host configuration protocol. A TCP/IP protocol that allows a server to assign an IP address based on a device name (host name) to a network node.

differential input

A type of input design where two wires (+ and -) are run from each signal source to the data acquisition interface. The voltage between the input and the interface ground are measured by two high-impedance amplifiers, and the outputs from the two amplifiers are subtracted by a third amplifier to yield the difference between the + and - inputs. Voltage common to both wires is thereby removed. Differential design solves the problem of ground differences found in single-ended connections, and it also reduces the cross-channel noise problem.

digital I/O

An input or output that has an individual circuit connection at the module corresponding directly to a data table bit or word that stores the value of the signal at that I/O circuit. It allows the control logic to have discrete access to the I/O values.

DIN

Deutsche industrial norms. A German agency that sets engineering and dimensional standards and now has worldwide recognition.

Drivecom Profile

The Drivecom profile is part of CiA DSP 402 (profile), which defines the behavior of drives and motion control devices on CANopen networks.

E

economy segment

A special type of STB I/O segment created when an STB NCO 1113 economy CANopen NIM is used in the first location. In this implementation, the NIM acts as a simple gateway between the I/O modules in the segment and a CANopen master. Each I/O module in an economy segment acts as a independent node on the CANopen network. An economy segment cannot be extended to other STB I/O segments, preferred modules or enhanced CANopen devices.

EDS

electronic data sheet. The EDS is a standardized ASCII file that contains information about a network device's communications functionality and the contents of its object dictionary. The EDS also defines device-specific and manufacturer-specific objects.

EIA

Electronic Industries Association. An organization that establishes electrical/electronic and data communication standards.

EMC

electromagnetic compatibility. Devices that meet EMC requirements can operate within a system's expected electromagnetic limits without error.

EMI

electromagnetic interference. EMI can cause an interruption, malfunction, or disturbance in the performance of electronic equipment. It occurs when a source electronically transmits a signal that interferes with other equipment.

EOS

This abbreviation stands for end of segment. When more than 1 segment of I/O modules is used in an Island, an STB XBE 1000 or an STB XBE 1100 EOS module is installed in the last position in every segment that has an extension following it. The EOS module extends Island bus communications to the next segment. Which EOS module must be selected depends on the module types that shall follow.

Ethernet

A LAN cabling and signaling specification used to LAN connect devices within a defined area, e.g., a building. Ethernet uses a bus or a star topology to connect different nodes on a network.

Ethernet II

A frame format in which the header specifies the packet type, Ethernet II is the default frame format for NIM communications.

EtherNet/IP

EtherNet/IP (the Ethernet Industrial Protocol) is especially suited to factory applications in which there is a need to control, configure, and monitor events within an industrial system. The ODVA-specified protocol runs CIP (the Common Industrial Protocol) on top of standard Internet protocols, like TCP/IP and UDP. It is an open local (communications) network that enables the interconnectivity of all levels of manufacturing operations from the plant's office to the sensors and actuators on its floor.

F**fallback state**

A known state to which an Advantys STB I/O module can return in the event that its communication connection fails.

fallback value

The value that a device assumes during fallback. Typically, the fallback value is either configurable or the last stored value for the device.

FED_P

Fipio extended device profile. On a Fipio network, the standard device profile type for agents whose data length is more than 8 words and equal to or less than 32 words.

Fipio

Fieldbus Interface Protocol (FIP). An open fieldbus standard and protocol that conforms to the FIP/World FIP standard. Fipio is designed to provide low-level configuration, parameterization, data exchange, and diagnostic services.

Flash memory

Flash memory is nonvolatile memory that can be overwritten. It is stored on a special EEPROM that can be erased and reprogrammed.

FRD_P

Fipio reduced device profile. On a Fipio network, the standard device profile type for agents whose data length is two words or less.

FSD_P

Fipio standard device profile. On a Fipio network, the standard device profile type for agents whose data length is more than two words and equal to or less than 8 words.

full scale

The maximum level in a specific range—e.g., in an analog input circuit the maximum allowable voltage or current level is at full scale when any increase beyond that level is over-range.

function block

A function block performs a specific automation function, such as speed control. A function block comprises configuration data and a set of operating parameters.

function code

A function code is an instruction set commanding 1 or more slave devices at a specified address(es) to perform a type of action, e.g., read a set of data registers and respond with the content.

G

gateway

A program or hardware that passes data between networks.

global_ID

global_identifier. A 16-bit integer that uniquely identifies a device's location on a network. A global_ID is a symbolic address that is universally recognized by all other devices on the network.

GSD

generic slave data (file). A device description file, supplied by the device's manufacturer, that defines a device's functionality on a Profibus DP network.

H

HMI

human-machine interface. An operator interface, usually graphical, for industrial equipment.

hot swapping

Replacing a component with a like component while the system remains operational. When the replacement component is installed, it begins to function automatically.

HTTP

hypertext transfer protocol. The protocol that a web server and a client browser use to communicate with one another.

I

I/O base

A mounting device, designed to seat an Advantys STB I/O module, hang it on a DIN rail, and connect it to the Island bus. It provides the connection point where the module can receive either 24 VDC or 115/230 VAC from the input or output power bus distributed by a PDM.

I/O module

In a programmable controller system, an I/O module interfaces directly to the sensors and actuators of the machine/process. This module is the component that mounts in an I/O base and provides electrical connections between the controller and the field devices. Normal I/O module capacities are offered in a variety of signal levels and capacities.

I/O scanning

The continuous polling of the Advantys STB I/O modules performed by the COMS to collect data bits, status, error, and diagnostics information.

IEC

International Electrotechnical Commission. Founded in 1884 to focus on advancing the theory and practice of electrical, electronics, and computer engineering, and computer science. EN 61131-2 is the specification that deals with industrial automation equipment.

IEC type 1 input

Type 1 digital inputs support sensor signals from mechanical switching devices such as relay contacts and push buttons operating in normal environmental conditions.

IEC type 2 input

Type 2 digital inputs support sensor signals from solid state devices or mechanical contact switching devices such as relay contacts, push buttons (in normal or harsh environmental conditions), and 2- or 3-wire proximity switches.

IEC type 3 input

Type 3 digital inputs support sensor signals from mechanical switching devices such as relay contacts, push buttons (in normal-to-moderate environmental conditions), 3-wire proximity switches and 2-wire proximity switches that have:

- a voltage drop of no more than 8 V
- a minimum operating current capability less than or equal to 2.5 mA
- a maximum off-state current less than or equal to 1.5 mA

IEEE

Institute of Electrical and Electronics Engineers, Inc. The international standards and conformity assessment body for all fields of electrotechnology, including electricity and electronics.

industrial I/O

An Advantys STB I/O module designed at a moderate cost for typical continuous, high-duty-cycle applications. Modules of this type often feature standard IEC threshold ratings, usually providing user-configurable parameter options, on-board protection, good resolution, and field wiring options. They are designed to operate in moderate-to-high temperature ranges.

input filtering

The amount of time that a sensor must hold its signal on or off before the input module detects the change of state.

input polarity

An input channel's polarity determines when the input module sends a 1 and when it sends a 0 to the master controller. If the polarity is *normal*, an input channel will send a 1 to the controller when its field sensor turns on. If the polarity is *reverse*, an input channel will send a 0 to the controller when its field sensor turns on.

input response time

The time it takes for an input channel to receive a signal from the field sensor and put it on the Island bus.

INTERBUS protocol

The INTERBUS fieldbus protocol observes a master/slave network model with an active ring topology, having all devices integrated in a closed transmission path.

IOC object

Island operation control object. A special object that appears in the CANopen object dictionary when the remote virtual placeholder option is enabled in a CANopen NIM. It is a 16-bit word that provides the fieldbus master with a mechanism for issuing reconfiguration and start requests.

IOS object

Island operation status object. A special object that appears in the CANopen object dictionary when the remote virtual placeholder option is enabled in a CANopen NIM. It is a 16-bit word that reports the success of reconfiguration and start requests or records errors in the event that a request fails.

IP

internet protocol. That part of the TCP/IP protocol family that tracks the internet addresses of nodes, routes outgoing messages, and recognizes incoming messages.

IP Rating

Ingress Protection rating according to IEC 60529.

IP20 modules are protected against ingress and contact of objects larger than 12.5 mm. The module is not protected against harmful ingress of water.

IP67 modules are completely protected against ingress of dust and contact. Ingress of water in harmful quantity is not possible when the enclosure is immersed in water up to 1 m.

L

LAN

local area network. A short-distance data communications network.

light industrial I/O

An Advantys STB I/O module designed at a low cost for less rigorous (e.g., intermittent, low-duty-cycle) operating environments. Modules of this type operate in lower temperature ranges with lower qualification and agency requirements and limited on-board protection; they usually have limited or no user-configuration options.

linearity

A measure of how closely a characteristic follows a straight-line function.

LSB

least significant bit, least significant byte. The part of a number, address, or field that is written as the rightmost single value in conventional hexadecimal or binary notation.

M

MAC address

media access control address. A 48-bit number, unique on a network, that is programmed into each network card or device when it is manufactured.

mandatory module

When an Advantys STB I/O module is configured to be mandatory, it must be present and healthy in the Island configuration for the Island to be operational. If a mandatory module fails or is removed from its location on the Island bus, the Island will go into a pre-operational state. By default, all I/O modules are not mandatory. You must use the Advantys Configuration Software to set this parameter.

master/slave model

The direction of control in a network that implements the master/slave model is always from the master to the slave devices.

Modbus

Modbus is an application layer messaging protocol. Modbus provides client and server communications between devices connected on different types of buses or networks. Modbus offers many services specified by function codes.

MOV

metal oxide varistor. A 2-electrode semiconductor device with a voltage-dependant nonlinear resistance that drops markedly as the applied voltage is increased. It is used to suppress transient voltage surges.

MSB

most significant bit, most significant byte. The part of a number, address, or field that is written as the leftmost single value in conventional hexadecimal or binary notation.

N**N.C. contact**

normally closed contact. A relay contact pair that is closed when the relay coil is de-energized and open when the coil is energized.

N.O. contact

normally open contact. A relay contact pair that is open when the relay coil is de-energized and closed when the coil is energized.

NEMA

National Electrical Manufacturers Association

network cycle time

The time that a master requires to complete a single scan of all of the configured I/O modules on a network device; typically expressed in microseconds.

NIM

network interface module. This module is the interface between an Island bus and the fieldbus network of which the Island is a part. A NIM enables all the I/O on the Island to be treated as a single node on the fieldbus. The NIM also provides 5 V of logic power to the Advantys STB I/O modules in the same segment as the NIM.

NMT

network management. NMT protocols provide services for network initialization, error control, and device status control.

O

object dictionary

Part of the CANopen device model that provides a map to the internal structure of CANopen devices (according to CANopen profile DS-401). A device's object dictionary (also called the *object directory*) is a lookup table that describes the data types, communications objects, and application objects the device uses. By accessing a particular device's object dictionary through the CANopen fieldbus, you can predict its network behavior and build a distributed application.

ODVA

Open Devicenet Vendors Association. The ODVA supports the family of network technologies that are built on the Common Industrial Protocol (EtherNet/IP, DeviceNet, and CompoNet).

open industrial communication network

A distributed communication network for industrial environments based on open standards (EN 50235, EN50254, and EN50170, and others) that allows the exchange of data between devices from different manufacturers.

output filtering

The amount that it takes an output channel to send change-of-state information to an actuator after the output module has received updated data from the NIM.

output polarity

An output channel's polarity determines when the output module turns its field actuator on and when it turns the actuator off. If the polarity is *normal*, an output channel will turn its actuator on when the master controller sends it a 1. If the polarity is *reverse*, an output channel will turn its actuator on when the master controller sends it a 0.

output response time

The time it takes for an output module to take an output signal from the Island bus and send it to its field actuator.

P

parameterize

To supply the required value for an attribute of a device at run-time.

PDM

power distribution module. A module that distributes either AC or DC field power to a cluster of I/O modules directly to its right on the Island bus. A PDM delivers field power to the input modules and the output modules. It is important that all the I/O clustered directly to the right of a PDM be in the same voltage group—either 24 VDC, 115 VAC, or 230 VAC.

PDO

process data object. In CAN-based networks, PDOs are transmitted as unconfirmed broadcast messages or sent from a producer device to a consumer device. The transmit PDO from the producer device has a specific identifier that corresponds to the receive PDO of the consumer devices.

PE

protective earth. A return line across the bus for fault currents generated at a sensor or actuator device in the control system.

peer-to-peer communications

In peer-to-peer communications, there is no master/slave or client/server relationship. Messages are exchanged between entities of comparable or equivalent levels of functionality, without having to go through a third party (like a master device).

PLC

programmable logic controller. The PLC is the brain of an industrial manufacturing process. It automates a process as opposed to relay control systems. PLCs are computers suited to survive the harsh conditions of the industrial environment.

PowerSuite Software

PowerSuite Software is a tool for configuring and monitoring control devices for electric motors, including ATV31, ATV71, and TeSys U.

preferred module

An I/O module that functions as an auto-addressable device on an Advantys STB Island but is not in the same form factor as a standard Advantys STB I/O module and therefore does not fit in an I/O base. A preferred device connects to the Island bus via an EOS module and a length of a preferred module extension cable. It can be extended to another preferred module or back into a BOS module. If it is the last device on the Island, it must be terminated with a 120 Ω terminator.

premium network interface

A premium NIM has advanced features over a standard or basic NIM.

prioritization

An optional feature on a standard NIM that allows you to selectively identify digital input modules to be scanned more frequently during a the NIM's logic scan.

process I/O

An Advantys STB I/O module designed for operation at extended temperature ranges in conformance with IEC type 2 thresholds. Modules of this type often feature high levels of on-board diagnostics, high resolution, user-configurable parameter options, and higher levels of agency approval.

process image

A part of the NIM firmware that serves as a real-time data area for the data exchange process. The process image includes an input buffer that contains current data and status information from the Island bus and an output buffer that contains the current outputs for the Island bus, from the fieldbus master.

producer/consumer model

In networks that observe the producer/consumer model, data packets are identified according to their data content rather than by their node address. All nodes *listen* on the network and consume those data packets that have appropriate identifiers.

Profibus DP

Profibus Decentralized Peripheral. An open bus system that uses an electrical network based on a shielded 2-wire line or an optical network based on a fiber-optic cable. DP transmission allows for high-speed, cyclic exchange of data between the controller CPU and the distributed I/O devices.

R

reflex action

A simple, logical command function configured locally on an Island bus I/O module. Reflex actions are executed by Island bus modules on data from various Island locations, like input and output modules or the NIM. Examples of reflex actions include compare and copy operations.

repeater

An interconnection device that extends the permissible length of a bus.

reverse polarity protection

Use of a diode in a circuit to protect against damage and unintended operation in the event that the polarity of the applied power is accidentally reversed.

rms

root mean square. The effective value of an alternating current, corresponding to the DC value that produces the same heating effect. The rms value is computed as the square root of the average of the squares of the instantaneous amplitude for 1 complete cycle. For a sine wave, the rms value is 0.707 times the peak value.

role name

A customer-driven, unique logical personal identifier for an Ethernet NIM. A role name (or *device name*) is created when you:

- combine the numeric rotary switch setting with the NIM (for example, STBNIP2212_010), or . . .
- edit the **Device Name** setting in the NIM's embedded web server pages

After the NIM is configured with a valid role name, the DHCP server uses it to identify the island at power up.

RTD

resistive temperature detect. An RTD device is a temperature transducer composed of conductive wire elements typically made of platinum, nickel, copper, or nickel-iron. An RTD device provides a variable resistance across a specified temperature range.

RTP

run-time parameters. RTP lets you monitor and modify selected I/O parameters and Island bus status registers of the NIM while the Advantys STB Island is running. The RTP feature uses 5 reserved output words in the NIM's process image (the RTP request block) to send requests, and 4 reserved input words in the NIM's process image (the RTP response block) to receive responses. Available only in standard NIMs running firmware version 2.0 or higher.

Rx

reception. For example, in a CAN-based network, a PDO is described as an RxPDO of the device that receives it.

S

SAP

service access point. The point at which the services of 1 communications layer, as defined by the ISO OSI reference model, is made available to the next layer.

SCADA

supervisory control and data acquisition. Typically accomplished in industrial settings by means of microcomputers.

SDO

service data object. In CAN-based networks, SDO messages are used by the fieldbus master to access (read/write) the object directories of network nodes.

segment

A group of interconnected I/O and power modules on an Island bus. An Island must have at least 1 segment and, depending on the type of NIM used, may have as many as 7 segments. The first (leftmost) module in a segment needs to provide logic power and Island bus communications to the I/O modules on its right. In the primary or basic segment, that function is filled by a NIM. In an extension segment, that function is filled by an STB XBE 1200 or an STB XBE 1300 BOS module.

SELV

safety extra low voltage. A secondary circuit designed and protected so that the voltage between any 2 accessible parts (or between 1 accessible part and the PE terminal for Class 1 equipment) does not exceed a specified value under normal conditions or under single-fault conditions.

SIM

subscriber identification module. Originally intended for authenticating users of mobile communications, SIMs now have multiple applications. In Advantys STB, configuration data created or modified with the Advantys Configuration Software can be stored on a SIM and then written to the NIM's Flash memory.

single-ended inputs

An analog input design technique whereby a wire from each signal source is connected to the data acquisition interface, and the difference between the signal and ground is measured. For the success of this design technique, 2 conditions are imperative: the signal source must be grounded, and the signal ground and data acquisition interface ground (the PDM lead) must have the same potential.

sink load

An output that, when turned on, receives DC current from its load.

size 1 base

A mounting device, designed to seat an STB module, hang it on a DIN rail, and connect it to the Island bus. It is 13.9 mm (0.55 in.) wide and 128.25 mm (5.05 in.) high.

size 2 base

A mounting device, designed to seat an STB module, hang it on a DIN rail, and connect it to the Island bus. It is 18.4 mm (0.73 in.) wide and 128.25 mm (5.05 in.) high.

size 3 base

A mounting device, designed to seat an STB module, hang it on a DIN rail, and connect it to the Island bus. It is 28.1 mm (1.11 in.) wide and 128.25 mm (5.05 in.) high.

slice I/O

An I/O module design that combines a small number of channels (usually between 2 and 6) in a small package. The idea is to allow a system developer to purchase just the right amount of I/O and to be able to distribute it around the machine in an efficient, mechatronics way.

SM_MPS

state management_message periodic services. The applications and network management services used for process control, data exchange, error reporting, and device status notification on a Fipio network.

SNMP

simple network management protocol. The UDP/IP standard protocol used to manage nodes on an IP network.

snubber

A circuit generally used to suppress inductive loads—it consists of a resistor in series with a capacitor (in the case of an RC snubber) and/or a metal-oxide varistor placed across the AC load.

source load

A load with a current directed into its input; must be driven by a current source.

standard I/O

Any of a subset of Advantys STB input/output modules designed at a moderate cost to operate with user-configurable parameters. A standard I/O module may be reconfigured with the Advantys Configuration Software and, in most cases, may be used in reflex actions.

standard network interface

An Advantys STB network interface module designed at moderate cost to support the configuration capabilities, multi-segment design and throughput capacity suitable for most standard applications on the Island bus. An Island run by a standard NIM can support up to 32 addressable Advantys STB and/or preferred I/O modules, up to 12 of which may be standard CANopen devices.

standard power distribution module

An Advantys STB module that distributes sensor power to the input modules and actuator power to the output modules over two separate power buses on the Island. The bus provides a maximum of 4 A to the input modules and 8 A to the output modules. A standard PDM requires a 5 A fuse to protect the input modules and an 8 A fuse to protect the outputs.

STD_P

standard profile. On a Fipio network, a standard profile is a fixed set of configuration and operating parameters for an agent device, based on the number of modules that the device contains and the device's total data length. There are 3 types of standard profiles: Fipio reduced device profile (FRD_P), Fipio standard device profile (FSD_P), and the Fipio extended device profile (FED_P).

stepper motor

A specialized DC motor that allows discrete positioning without feedback.

subnet

A part of a network that shares a network address with the other parts of a network. A subnet may be physically and/or logically independent of the rest of the network. A part of an internet address called a subnet number, which is ignored in IP routing, distinguishes the subnet.

surge suppression

The process of absorbing and clipping voltage transients on an incoming AC line or control circuit. Metal-oxide varistors and specially designed RC networks are frequently used as surge suppression mechanisms.

T**TC**

thermocouple. A TC device is a bimetallic temperature transducer that provides a temperature value by measuring the voltage differential caused by joining together two different metals at different temperatures.

TCP

transmission control protocol. A connection-oriented transport layer protocol that provides reliable full-duplex data transmission. TCP is part of the TCP/IP suite of protocols.

telegram

A data packet used in serial communication.

TFE

transparent factory Ethernet. Schneider Electric's open automation framework based on TCP/IP.

Tx

transmission. For example, in a CAN-based network, a PDO is described as a TxPDO of the device that transmits it.

U

UDP

user datagram protocol. A connectionless mode protocol in which messages are delivered in a datagram to a destination computer. The UDP protocol is typically bundled with the Internet Protocol (UDP/IP).

V

varistor

A 2-electrode semiconductor device with a voltage-dependant nonlinear resistance that drops markedly as the applied voltage is increased. It is used to suppress transient voltage surges.

voltage group

A grouping of Advantys STB I/O modules, all with the same voltage requirement, installed directly to the right of the appropriate power distribution module (PDM) and separated from modules with different voltage requirements. Never mix modules with different voltage requirements in the same voltage group.

VPCR object

virtual placeholder configuration read object. A special object that appears in the CANopen object dictionary when the remote virtual placeholder option is enabled in a CANopen NIM. It provides a 32-bit subindex that represents the actual module configuration used in a physical Island.

VPCW object

virtual placeholder configuration write object. A special object that appears in the CANopen object dictionary when the remote virtual placeholder option is enabled in a CANopen NIM. It provides a 32-bit subindex where the fieldbus master can write a module reconfiguration. After the fieldbus writes to the VPCW subindex, it can issue a reconfiguration request to the NIM that begins the remote virtual placeholder operation.

W**watchdog timer**

A timer that monitors a cyclical process and is cleared at the conclusion of each cycle. If the watchdog runs past its programmed time period, it generates a fault.

Index



A

- Advantys configuration software, *154*
- Advantys STB modules
 - inserting and removing from bases, *153*
 - installing, *102*
- agency approvals, *24*
- analog I/O modules
 - CE compliance for, *127*

B

- baud
 - CFG port, *154*

C

- cable channels, *75*
- CFG port
 - devices connecting to, *154, 155*
 - parameters, *154*
 - physical description, *154*
 - specifications, *154*
- configuring a preferred module, *114*
- configuring the island, *142*
 - auto-configuration, *142*
 - custom configuration, *142*
 - removable memory card, *143*
- cooling the cabinet, *50*

D

- data exchange, *156*

E

- electromagnetic susceptibility specifications, *25*
- emission specifications, *25*
- environmental system specifications, *24*
- EOS/BOS modules
 - extending the island, *111*
- EOS/BOS modules compatibility
 - installing extension segments, *109, 114*
- extending the island
 - connecting to EOS/BOS modules, *111*
 - connecting to preferred modules, *115*
- extending the island bus
 - to extension segments, *108*
 - to preferred devices, *108*
 - to standard CANopen devices, *108*

F

- factory default settings, *154*
- fault detection, *154*
- FE, *126*
- fieldbus connections, *138*
- functional earth, *126*

H

- HE-13 connector, *155*
- HMI panel, *155*
- hot swapping
 - I/O modules, *146*

I

- Insertion/removal cycles
 - Advantys STB modules and bases, *153*
- installing extension segments
 - EOS/BOS modules compatibility , *109, 114*
- island bus
 - LEDs, *156*
 - mastery of, *156*
 - operational mode, *156*
- Isolation requirements, *122*

K

- keying
 - I/O module field wire connectors, *88*
 - I/O to base connection, *86*
 - NIM power connection, *90*
 - PDM power connection, *91*
- keying kits, *83*

L

- label kit
 - for STB modules and their bases, *74*
- label printing template, *74*
- LEDs, *155*
 - and COMS states, *156*
 - and reset, *156*
 - BUS FLT LED, *156*
 - island bus, *156*
 - PWR LED, *156*
 - TEST LED, *156*

M

- Modbus protocol, *155*

N

- NIM
 - installing and removing, *77*

P

- power connections, *138, 138*
- preferred module
 - connected to EOS, *116*
- preferred modules
 - extending the island, *115*
 - installation, *114*

R

- RFI/EMI
 - suppressing with EMC kit, *127*
- RST button, *142*
 - LED indications, *156*

S

- SELV-rated isolation
 - in the 24 VDC power source, *122*
- specifications
 - electromagnetic susceptibility, *25*
 - emission, *25*
 - environmental, *24*
 - environmental, systemwide, *24*
- STB SPU 1000 Advantys configuration software
 - to configure preferred modules, *114*
- STB XBE 1000 EOS module
 - EOS/BOS module compatibility, *110*
- STB XBE 1100 EOS module
 - connection to preferred module, *116*
- STB XCA 4002 programming cable, *155*
- STB XCA 4002 programming cable
 - specifications, *155*
- STB XMP 4440 removable memory card and reset, *154*
- STB XMP 6700 marking label kit, *74*
- STB XMP 7700 module keying pin kit, *86*
- STB XMP 7800 I/O connector keying pin kit, *88, 91*
- STB XMP 7810 PDM connector keying pin kit, *91*
- STB XTS 1120 screw type power connector, *111*
- STB XTS 2120 spring clamp field wiring con-

nector, 111

T

test mode, 156

testing

your application with live inputs, 123

troubleshooting, 154

using the Advantys STB LEDs, 156

V

voltage cut-out switching

relays for, 123

W

wattage dissipation

in a system cabinet, 50