



# **OWH67 Series Program Power Supply User Manual**



## General Warranty

We warrant that the product will be free from defects in materials and workmanship for a period of 2 years from the date of purchase of the product by the original purchaser from our company. The warranty period for accessories such as probes, battery is 12 months. This warranty only applies to the original purchaser and is not transferable to a third party.

If the product proves defective during the warranty period, we will either repair the defective product without charge for parts and labour, or will provide a replacement in exchange for the defective product. Parts, modules and replacement products used by our company for warranty work may be new or reconditioned like new. All replaced parts, modules and products become the property of our company.

In order to obtain service under this warranty, the customer must notify our company of the defect before the expiration of the warranty period. Customer shall be responsible for packaging and shipping the defective product to the designated service centre, a copy of the customers proof of purchase is also required.

This warranty shall not apply to any defect, failure or damage caused by improper use or improper or inadequate maintenance and care. We shall not be obligated to furnish service under this warranty a) to repair damage resulting from attempts by personnel other than our company representatives to install, repair or service the product; b) to repair damage resulting from improper use or connection to incompatible equipment; c) to repair any damage or malfunction caused by the use of not our supplies; or d) to service a product that has been modified or integrated with other products when the effect of such modification or integration increases the time or difficulty of servicing the product.

Please contact the nearest Sales and Service Offices for services.

**Excepting the after-sales services provided in this summary or the applicable warranty statements, we will not offer any guarantee for maintenance definitely declared or hinted, including but not limited to the implied guarantee for marketability and special-purpose acceptability. We should not take any responsibilities for any indirect, special or consequent damages.**

# Table of Contents

1. General Safety Requirement .....	1
2. Safety Terms and Symbols .....	3
3. Quick Start .....	4
3.1 Front Panel and Interface .....	4
3.1.1 Front Panel .....	4
3.1.2 Rear Panel .....	5
3.1.3 User Interface .....	7
3.2 General Inspection .....	7
3.3 Power-on Inspection .....	8
3.4 Output Inspection .....	8
3.4.1 Voltage Output Inspection .....	9
3.4.2 Current Output Inspection .....	9
4. Functional features and Panel operation .....	10
4.1 Turn On/Off the Channel Output .....	10
4.2 Local/Remote mode Operation switch .....	11
4.3 Output Voltage/Current Setting .....	11
4.3.1 Set the Output Voltage/Current .....	11
4.4 Adjust Output Voltage/Current and Power .....	12
4.5 Input current limitation and output power derating .....	12
4.6 System menu function .....	13
4.6.1 System setup .....	16
4.6.2 Mode setup .....	16
4.6.3 Output setup .....	17
4.6.4 Protect Setup .....	28
4.6.5 Remote Setup .....	29
4.6.6 Series/Parallel Setup .....	30
4.6.7 System Setup .....	33
4.6.8 Fault Information .....	33
4.7 Waveform display Function .....	34
4.8 Remote Measurement Function .....	34
5. Troubleshooting .....	37
6. Technical Specification .....	38
7. Appendix .....	40

7.1 Appendix A: Accessories .....	40
7.2 Appendix B: General Care and Cleaning .....	40

# 1. General Safety Requirement

Before any operations, please read the following safety precautions to avoid any possible bodily injury and prevent this product or any other products connected from damage. In order to avoid any contingent danger, this product is only used within the range specified.

Only the qualified technicians can implement the maintenance.

To avoid Fire or Personal Injury:

**Use Proper Power Cord.** Use only the power cord supplied with the product and certified to use in your country.

**Product Grounded.** This instrument is grounded through the power cord grounding conductor. To avoid electric shock, the grounding conductor must be grounded. The product must be grounded properly before any connection with its input or output terminal.

**Limit operation to the specified measurement category, voltage, or amperage ratings.**

**Check all Terminal Ratings.** To avoid fire or shock hazard, check all ratings and markers on the instrument. Refer to the user's manual for more information about ratings before connecting the instrument. Do not exceed any of ratings defined in the following section.

**Do not operate without covers.** Do not operate the instrument with covers or panels removed.

**Use Proper Fuse.** Use only the specified type and rating fuse for this instrument.

**Avoid exposed circuit.** Do not touch exposed junctions and components when the instrument is powered.

**Do not operate if in any doubt.** If you suspect damage occurs to the instrument, have it inspected by qualified service personnel before further operations.

**Use your instrument in a well-ventilated area.** Inadequate ventilation may cause an increasing of temperature or damages to the instrument. Please keep the instrument well ventilated, and inspect the air outlet and the fan regularly.

**Do not operate in wet conditions.** To avoid short circuit inside the instrument or electric shock, never operate the instrument in a humid

environment.

**Do not operate in an explosive atmosphere.** In order to avoid damages to the device or personal injuries, it is important to operate the device away from an explosive atmosphere.

**Keep instrument surfaces clean and dry.** To avoid the influence of dust or moisture in air, please keep the surface of device clean and dry.

## 2. Safety Terms and Symbols

### Safety Terms

**Terms in this Manual.** The following terms may appear in this manual:

 **Warning:** Warning indicates the conditions or practices that could result in injury or loss of life.

 **Caution:** Caution indicates the conditions or practices that could result in damage to this product or other property.

**Terms on the Product.** The following terms may appear on this product:

**Danger:** It indicates an injury or hazard may immediately happen.

**Warning:** It indicates an injury or hazard may be accessible potentially.

**Caution:** It indicates a potential damage to the instrument or other property might occur.

### Safety Symbols

**Symbols on the Product.** The following symbol may appear on the product:

 Hazardous Voltage

 Refer to Manual

 Protective Earth Terminal

 Chassis Ground

 Public Ground

## 3. Quick Start

### 3.1 Front Panel and Interface

#### 3.1.1 Front Panel

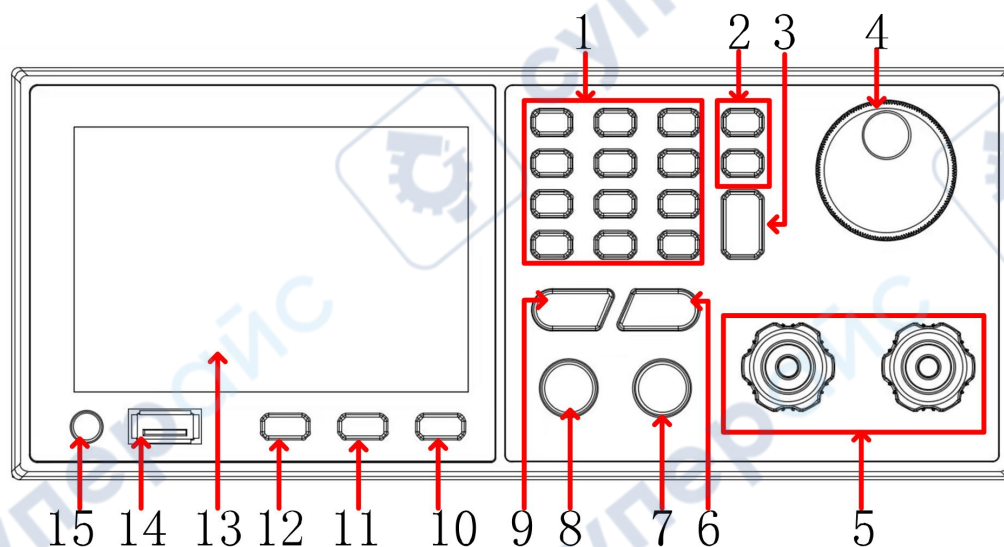

Figure 3-1 Front panel overview

1	<b>0-9 and . Esc</b>	Number and dot key: input number; Esc key: return to the previous page.
2	<b>&lt; &gt;</b>	Cursor movement key: Use to move the cursor left and right to the desired parameter position.
3	<b>Enter</b>	Confirm parameter setting.
4	<b>Knob</b>	Users can turn the knob to enter programming information or options.
5	<b>DC source output terminal</b>	The output connection of the DC source.
6	<b>CURR</b>	Current setting key: press it to enter the current setting mode, at the same time, user can input current value by numeric box or knob.
7	<b>ON/OFF</b>	Control the output status: ON or OFF.

8	<b>LOCK</b>	Lock all buttons and knobs; Way to remove: press and hold the LOCK key to remove the setting.
9	<b>VOLT</b>	Voltage setting key: press it to enter the voltage setting mode, at the same time, user can input voltage value by numeric box or knob.
10	<b>SHIFT</b>	Reuse function keys.
11	<b>DISP</b>	Switch output digital display and waveform display.
12	<b>CONF</b>	Switch the page into configure page, to set up various functions.
13	<b>Display area</b>	TFT color screen display, output Settings and measurement results.
14	<b>USB</b>	USB data interface.
15	<b>Power button</b>	Turn on/off instrument.

### 3.1.2 Rear Panel

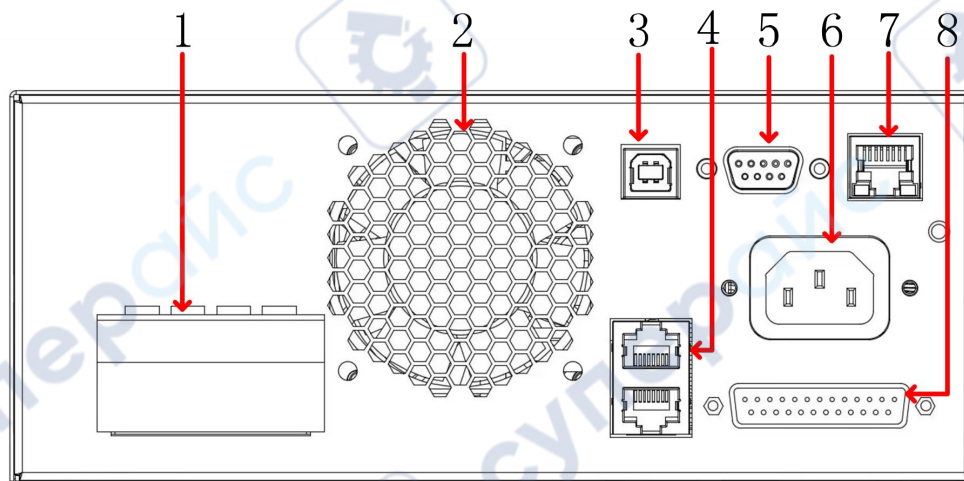

Figure 3-2 Rear panel overview

1	<b>DC output terminal + Remote compensation</b>	The DC power output terminal is equipped with a remote compensating sampling terminal, which is connected to the load terminal to compensate for the voltage drop on the line. Please make sure that Vsen+ is connected to output +, Vsen- is connected
---	---	---

	to output -, do not connect to reverse or floating.
<b>2 Fan</b>	Do not block the outlet of the fan, otherwise the internal heat dissipation of the machine will lead to excessive internal temperature.
<b>3 USB terminal</b>	The computer can be connected through the USB port.
<b>4 CAN interface</b>	Multiple parallel machines can be made through the CAN port.
<b>5 RS485 interface</b>	The computer can be connected through the RS485 port.
<b>6 AC Power connection terminal</b>	Power cord input AC power, from this connection terminal to the input terminal.
<b>7 LAN interface</b>	Ethernet remote communication controller can be connected to a computer through this interface for remote operation.
<b>8 Analog signal connection terminal</b>	DB25 terminal: APG input/output terminal and system status, please refer to Appendix A.

### 3.1.3 User Interface

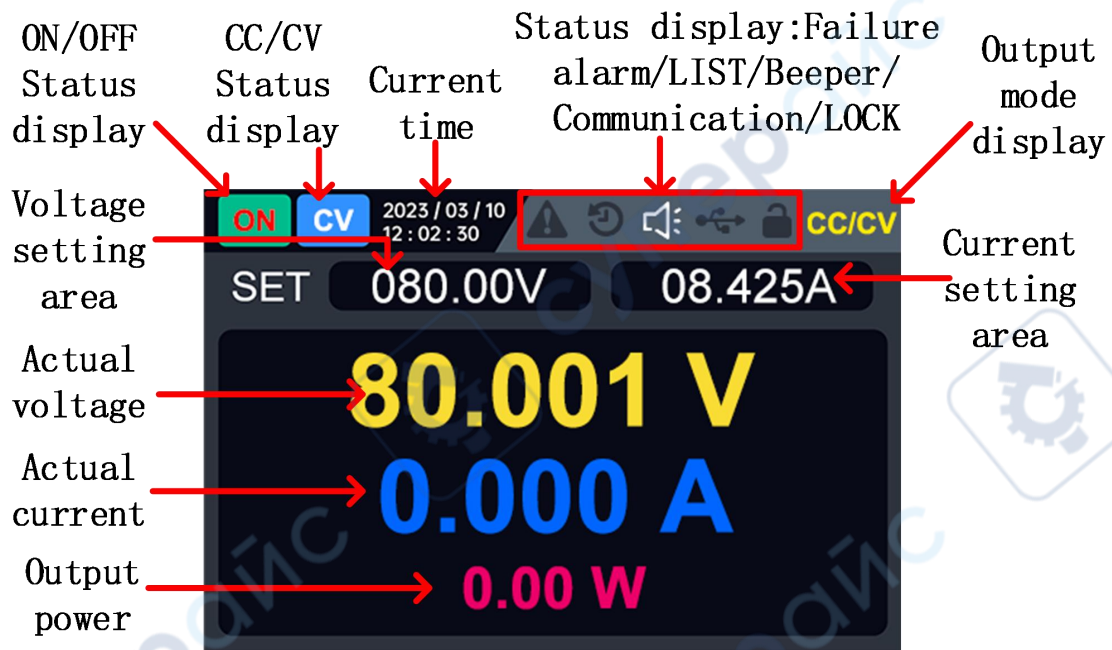







Figure 3-3 User interface

#### Status Icon

Icon	Description
	The panel keys are locked
	Panel USB data cable is transmitting
	Enable beeper
	Enable LIST function
	Record status
	A failure alarm

### 3.2 General Inspection

After you get a new OWH67 series AC power supply, it is recommended that you should make a check on the instrument according to the following steps:

1. Check whether there is any damage caused by transportation.

If it is found that the packaging carton or the foamed plastic protection cushion has suffered serious damage, do not throw it away first till the complete device and its accessories succeed in the electrical and mechanical property tests.

## 2. Check the Accessories.

The supplied accessories have been already described in Appendix A: Accessories of this manual. You can check whether there is any loss of accessories with reference to this description. If it is found that there is any accessory lost or damaged, please get in touch with our distributor responsible for this service or our local offices.

## 3. Check the Complete Instrument.

If it is found that there is damage on the first appearance of the instrument, or the instrument cannot work normally, or fails in the performance test, please get in touch with our distributor responsible for this business or our local offices. If there is damage to the instrument caused by the transportation, please keep the package. With the transportation department or our distributor responsible for this business informed about it, a repairing or replacement of the instrument will be arranged by us.

## 3.3 Power-on Inspection

- (1) Connect the instrument to an AC power source using the power cord supplied with the accessory.



### Warning:

To prevent electric shock, make sure the instrument is properly grounded.

---

- (2) Press the **power button** on the front panel and the startup screen will be displayed on the screen.

## 3.4 Output Inspection

Output inspection is to ensure that the instrument can achieve its rated outputs and properly respond to operation from the front panel. For the

procedures below, it is suggested that you read "Turn On/Off the Channel Output" on page 10 and "Set the Output Voltage/Current" on page 11.

### **3.4.1 Voltage Output Inspection**

The following steps verify basic voltage functions without load:

- (1) When the instrument is under no load, select a channel and ensure the output current setting for this channel is not at zero.
- (2) Turn on the channel output, then ensure the channel is in Constant Voltage output mode.
- (3) Set some different voltage values on this channel; check if the actual voltage value displayed is close to the set voltage value, and also that the actual current value displayed is nearly to zero.
- (4) Check if the output voltage can be adjusted from zero to the maximum rating.

### **3.4.2 Current Output Inspection**

The following steps check basic current functions to directly short the output two terminals:

- (1) Starting up.
- (2) Connect a short across (+) and (-) output terminals with an insulated test lead on this channel. Use a wire size sufficient to handle the maximum current.
- (3) Set the output voltage to the maximum rating on this channel.
- (4) Turn on the channel output. Ensure the channel you used is in Constant Current output mode.
- (5) Set some different current values on this channel; check if the actual current value displayed is close to the set current value, and to check if the actual voltage value displayed is nearly zero.
- (6) Check that if the output current can be adjusted from zero to the maximum rating.
- (7) Turn off the channel output and remove the short circuit from the output terminals.

## 4. Functional features and Panel operation

This chapter will describe OWH67 program power supply function feature and panel operations in details, it will be divided into the following sections:

- Turn on/off channel output
- Local/Remote mode operation switch
- Output voltage/current setting
- Adjust output voltage/current and power value
- System menu function
- Waveform display function
- Remote measurement function

### 4.1 Turn On/Off the Channel Output

Press the **ON/OFF** key to turn on/off the channel. When the **ON/OFF** key is bright, the output is turned ON; when the **ON/OFF** key light is off, the output is turned off. When the power is turned on, the panel defaults to the main interface to display the current state.

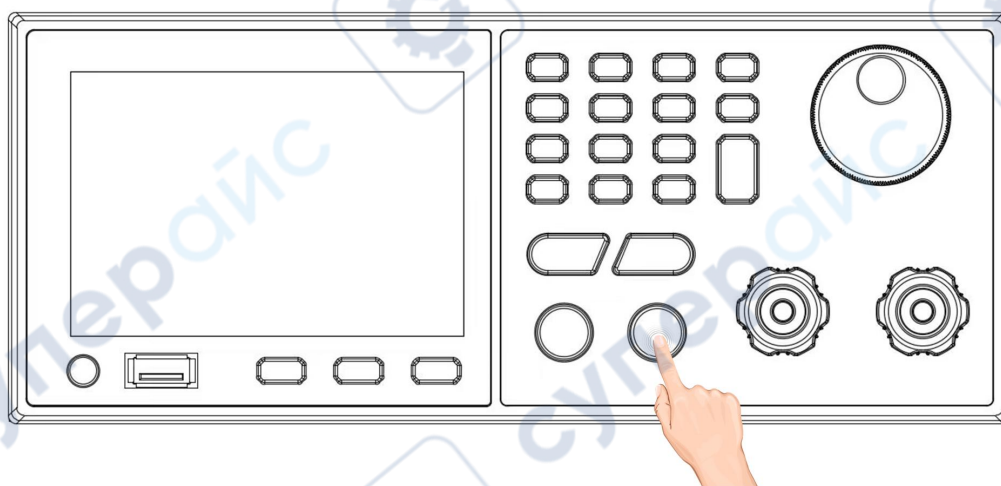

**Press the button, the indicator light shows that the output is open; Press the key again and the indicator light goes off to indicate that the output is off.**

#### **Description:**

After the power supply is connected with the object to be tested, press the **ON/OFF** key to open the output to avoid the possible ignition phenomenon. If

there is no power output after the output is turned on, please check the voltage and current setting value, please set the voltage and current is according the setting values and not 0 value, and then turn on the output.

## 4.2 Local/Remote mode Operation switch

The power supply provides both local and remote operation mode, and the two modes can be switched by communication commands. In power initialization mode, the machine is operated locally by default.

- Local operation mode: Use the keys on the panel to perform relevant operations.
- Remote operation mode: The power supply is connected to the PC, and the PC performs relevant operations on the power supply. When the power is in remote mode, all the buttons in the panel do not work except for the LOCK key. You can switch to local operation mode by press and hold **LOCK** key. When the operation mode is changed, it will not affect the output parameters of the power supply.

## 4.3 Output Voltage/Current Setting

### 4.3.1 Set the Output Voltage/Current

There are two ways to set the output voltage (CV mode):

Mode one:

1. Press **VOLT** key, at this time, the voltage number of the user interface will display cursor.
2. Use the numeric **0-9** softkey to set desired voltage. Press **Enter** key to save voltage setting, or turn the **knob** to adjust directly to the set value.
3. Press **ON/OFF** key to output the setting voltage.

Mode two:

1. Press **VOLT** , at this time, the voltage number of the user interface will display cursor.
2. Use the left and right direction function keys to move the cursor to different

bits, and turn the **knob** to increase or decrease the value.

3. Press **ON/OFF** key to output the setting voltage.

---

**Note:**The current setting must be greater than the load current to maintain the output in CV mode, otherwise the output voltage may not be equal to the set voltage.

---

Set the current (CC MODE) as follows:

Press **CURR** key, the rest of the settings are the same as the voltage setting. Note that the voltage setting must be greater than the load voltage to maintain the output in CC mode, otherwise the output current will not equal the set current.

## 4.4 Adjust Output Voltage/Current and Power

The output voltage and load resistance of the OWH67 program power supply determine the output current. For example: “4.3 Output Voltage/Current Setting”, only when the output current is lower than the set current limit value, the product is operated in constant voltage CV mode and is indicated by CV status.

If the output current is limited by the current set point or rated current, the product will be converted to constant current mode CC and indicated by CC status.

The output of voltage and current is also controlled by the limit power, because the voltage and current and the power limit affect each other, take OWH67012-80(80V/30A/1200W) as an example, when the voltage is set to 60V, the maximum current can only be set to 20A due to the power limitation; when the voltage value is set to 80V, the current can only be set to 15A due to the power limitation.

## 4.5 Input current limitation and output power derating

To ensure the input AC cable does not exceed its rated current capacity, the system incorporates an intelligent output power derating mechanism. This

mechanism dynamically adjusts the maximum output power ( $P_{out}$ ) based on the input voltage ( $V_{in}$ ), maintaining the input current within safe operating limits.

- For 3000W below models (OWH67012/18/20), the input current is limited to 10 A max.
- For 3000 W models (OWH67030), the input current is limited to 16 A max.

This means when the input voltage drops below the nominal range, the maximum output power will derate accordingly to prevent input current overload, and the warning message of “INPUT POWER LIMIT” will be shown on the screen.

Please refer to the  $P_{out}$  vs.  $V_{in}$  characteristics curve below for detailed derating behavior under low AC input voltage condition

OWH67012/18/20

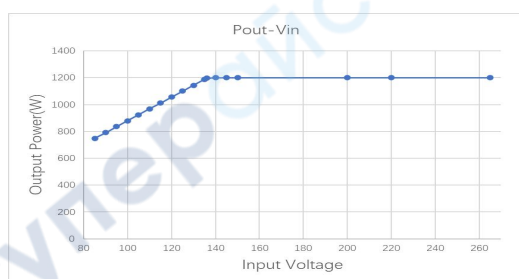

OWH67030

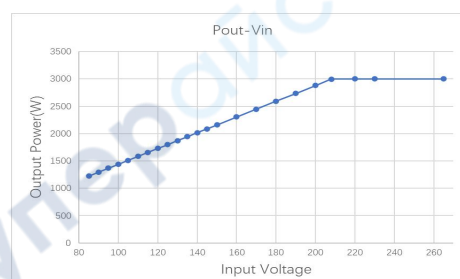

## 4.6 System menu function

System function Settings provide users with various system function Settings for OWH67 series program power supply. The system functions include the following:

1. SYSTEM SETUP
2. MODE SETUP
3. OUTPUT SETUP
4. PROTECT SETUP
5. REMOTE SETUP
6. SERIES/PARALLEL
7. SYSTEM INFO
8. FAULT INFO

Detailed operation steps:

Press **CONF** key to enter “Function menu” options setting.

1. Turn the **knob** to select desired setting item.

2. Press **Enter** to confirm.
3. Press **Esc** or **CONF** to return CONFIG PAGE.

**Note:**

1. If want to cancel setting, press **Esc** to return the CONFIG PAGE.
2. Press **VOLT** or **CURR** from any setting page to quickly navigate back to the CONFIG PAGE.

Menu as shown below:

Menu function	Settings	Descriptions	
<b>SYSTEM SETUP</b>	DISPLAY SETUP	BACKLIGHT	0-100%
		LANGUAGE	Chinese/ENGLISH
	SOUND SETUP	ALARM	ON/OFF
		KEY BEEP	ON/OFF
	TIME SETUP	YEAR/MONTH/DAY/HOUR/MINUTE/SECOND	
	RESTORE FACTORY	DETERMINE/CANCEL	
CALIBRATION	Default password:123456		
<b>MODE SETUP</b>	CC/CV MODE		
	LIST MODE		
	PV MODE		
	APG MODE		
<b>OUTPUTS SETUP</b>	CC/CV SETUP	V LIMIT(MAX)	
		I LIMIT(MAX)	
		V SLEW RATE	
		I SLEW RATE	
		CC/CV PRIOR	
	LIST SETUP	IMP./EXP.	
		LIST SETUP (STEP,CYC,VOLTAGE(V), CURRENT(A),TIME(s))	
		MODE	AUTO
			MANUAL
			EXT-TRI
PV SETUP	TYPE	EN50530	MATERIAL TYPE
			V_MAX
			P_MAX
			TC
			TREF
		Sandia	MATERIAL TYPE
			V_MAX
			P_MAX

				TC	
				TREF	
				IRRADIANCE	
	APG SETUP	APG VSET	Vref(0-10V)		
		APG ISET	Iref(0-10V)		
		APG VMEAS	Vref(0-10V)		
		APG IMEAS	Iref(0-10V)		
<b>PROTECT SETUP</b>	OVP	1-85V	OWH67012-80		
		1-155V	OWH67012-150 OWH67018-150 OWH67020-150 OWH67030-150		
		1-305V	OWH67012-300 OWH67020-300 OWH67030-300		
		1-605V	OWH67020-600 OWH67030-600		
	OCP	1-11A	OWH67020-600 OWH67030-600		
		1-15A	OWH67012-300 OWH67020-300		
		1-20A	OWH67030-300		
		1-25A	OWH67012-150 OWH67020-150		
		1-35A	OWH67012-80 OWH67018-150 OWH67030-150		
	OPP	10W - 1300W	OWH67012-80 OWH67012-150 OWH67012-300		
		10W - 1900W	OWH67018-150		
		10W - 2100W	OWH67020-150 OWH67030-150 OWH67020-600		
		10W - 3100W	OWH67030-150 OWH67030-300 OWH67030-600		
	<b>REMOTE SETUP</b>	USB(RS232)	BAUD RATE	2400-115200	
		RS485	BAUD RATE	2400-115200	
		LAN	DHCP	IP ADDR	
GATEWAY					
SUBNET MASK					
	DHCP	ON/OFF			
<b>SERIES/P ARALLEL</b>	PARALLEL MODE	SERIES/PARALLEL			
	MASTER/SLAVE	MASTER/SLAVE			
	PARALLEL CONTROL	ENABLE/DISABLE			
	PARALLEL STATE SLAVE NUM				
<b>SYSTEM INFO</b>	Model etc.				

<b>FAULT INFO</b>	MAINS AC FAULT	Failure free:Normal Be out of order: Error: (code)
	INTERNAL FAULT1	
	INTERNAL FAULT2	
	OUTPUT FAULTS	
	SERIES/PARALLEL	
	COMM FAULTS	
	INPUT POWER LIMIT	

### 4.6.1 System setup

Select **SYSTEM SETUP**, press **Enter** key to enter “SYSTEM” options setting, as shown in the below figure.



### 4.6.2 Mode setup

Select **MODE SETUP**, press **Enter** key to enter “MODE” options setting, OWH67 series products support four output modes.

- CC/CV MODE
- LIST MODE
- PV MODE
- APG MODE

The mode setting edit box can be determined by selecting any of the modes by the knob. After pressing **ON/OFF** key, the mode is locked and cannot be

edited. If you need to change to another mode, you need to power off and re-select the corresponding mode.

### 4.6.3 Output setup

The mode setup is associated with the output setup. After selecting the output mode of the mode setting, it can be directly associated with the setting interface of the corresponding mode when clicking the output setting. For example, when the output mode is set to CC/CV mode, the mode in the upper right corner will change to CC/CV icon, and then click Output Settings to directly enter the CC/CV setting interface.

#### 4.6.3.1 CC/CV Setup

CC/CV mode setup includes four parts:

- V LIMIT(MAX):

The maximum voltage can be set to 81V (OWH67012-80); 151V (OWH67012-150,OWH67018-150, OWH67020-150, OWH67030-150); 301V(OWH67012-300,OWH67020-300,OWH67030-300); 601V(OWH67020-600, OWH67030-600).

- I LIMIT(MAX):

The maximum current can be set to 11A (OWH67012-300, OWH67020-300, OWH67020-600, OWH67030-600); 16A (OWH67030-300); 21A (OWH67012-150, OWH67020-150); 31A (OWH 67012-80, OWH67018-150, OWH 67030-150).

- V SLEW RATE:

Voltage slew rate range can be set from 0.02V/ms to 0.2V/ms.

- I SLEW RATE:

Current slew rate range can be set from 0.02A/ms to 1A/ms.

- CC/CV PRIOR

Mode set CV first (default), if the user knows in advance that the

connected load characteristic, you can eliminate voltage/current overshoots when the output is turned on by switching the CV/CC priority mode.

#### 4.6.3.2 LIST Setup

The LIST setting interface is composed of two parts: the upper partition and the lower partition. The upper partition includes import, export, loading curve, mode selection, setting the total number of steps and cycle times. The lower partition is the editing area of the specific number of steps and is composed of the number of steps, voltage, current and time. User can press  $\leftarrow$ ,  $\rightarrow$  to select these two partitions to quickly configure and manage the LIST schema.

Users can set the total number of steps, the number of cycles, and the trigger mode of LIST mode in the upper partition, and edit the voltage, current, and time of each step in the lower partition.

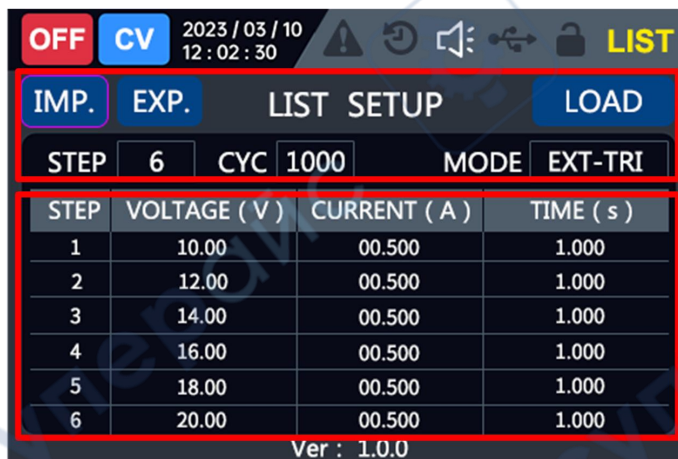

Press  $\leftarrow$  key to enter the upper partition

Press  $\rightarrow$  key to enter the lower partition

There are three TRIGGER modes of LIST curve: AUTO, EXT-TRI and MANUAL. In automatic trigger, the running time of each STEP needs to be set. Note: When external trigger and manual trigger are selected, the runtime is determined by the external trigger source.

You can set a LIST curve either by creating a new one or by importing it. To create a new LIST curve, follow these steps:

- Set the total number of steps: Press  $\leftarrow$  key, the cursor jump to the upper

partition, through the knob, select the total number of steps edit box, through the **Enter** key or **knob** to enter or exit editing, the total number of steps is a positive integer not exceeding 100. For example, if the total number of steps is 6, the edit area will generate 6 editable data.



- Cycle number setting: Press **←** key, the cursor to jump to the upper partition, select the editing box of cycle number through the **knob**. Enter or exit editing through the **Enter** key or knob. The number of cycles is 0-1000, where 1-1000 represents the LIST curve cycle running 1-1000 times, 0 represents the LIST curve infinite cycle running, input 0 will display INF.
- Trigger mode setting: Select the Trigger mode option box via the **knob**, can select AUTO, EXT-TRI, or MANUAL, the automatic trigger mode needs to set the running time of each step, and the running time of external trigger and manual trigger is infinite (INF). Among them, the automatic trigger (AUTO) only needs to be started at the beginning, and the power supply can be automatically operated according to the preset total number of steps, the number of cycles, and the voltage/current/time of each step. The external trigger can be triggered by the signal of the TRIGGER pin of DB25. The machine performs one step after every TRIGGER pulse signal. For the setting of the Trigger pin of DB25, please

refer to "4.5.3.4 APG setup". MANUAL trigger can be triggered by **VOLT**, the voltage setting key of the panel, and one step is executed for each setting. Manual trigger also supports the SCPI command of the host computer as the trigger source. Please see SCPI Instruction programming set for details.

- Edit curve: Press **↵** key, the cursor to jump to the lower partition. Edit the voltage, current and time data of a step, select a step of data through the **knob**. Enter or exit the voltage, current and time editing through the **Enter** key or the **knob**. When all the steps are set, the LIST curve is set.
- Load curve: Press **⏪** key, the cursor to jump to the upper partition, through the **knob** to select **LOAD**, the panel sends the curve to the lower machine, and the page jumps to the main page of LIST.

Press **ON/OFF**, on the running main page, can see the current voltage/current/step/total step/cycle times/total cycle times, and historical voltage and current curves.

After editing the LIST parameters, users can also directly start the computer by pressing the **ON/OFF** button. The system will automatically load the curve, edit the curve, go to the main page of the LIST and run the LIST curve.



Users can also edit and save curves by means of import and export.

Through the **knob**, select the **IMP.**, and press **Enter** to jump to the file management page. Select the LIST curve that needs to be imported by the **knob**, and then press the **knob** or **Enter** key to import the curve, at the same time, the page switches back to the LIST setting screen, the total number of steps to import the curve, the voltage, current, and time for each step are loaded to the page. It should be noted that the number of cycles and the trigger mode are set to 1 by default, and the AUTO mode is automatically triggered. Finally, through the **knob**, select the "LOAD", and the panel will send the curve. At the same time, the page jumps to the main page of LIST operation, and press the **ON/OFF** button to run the LIST curve.

When the user needs to export the curve, through the **knob**, select the **EXP.**, and press the **Enter** key to jump to the file management page. By default, the system names the file according to the time. After saving, the **Esc** key is used to exit the file management interface and return to the LIST setting interface. The remaining operations are similar to the import.

If there is a need to edit more steps, it is recommended that users directly use the host computer to operate. The following is the main interface of the host computer of LIST:

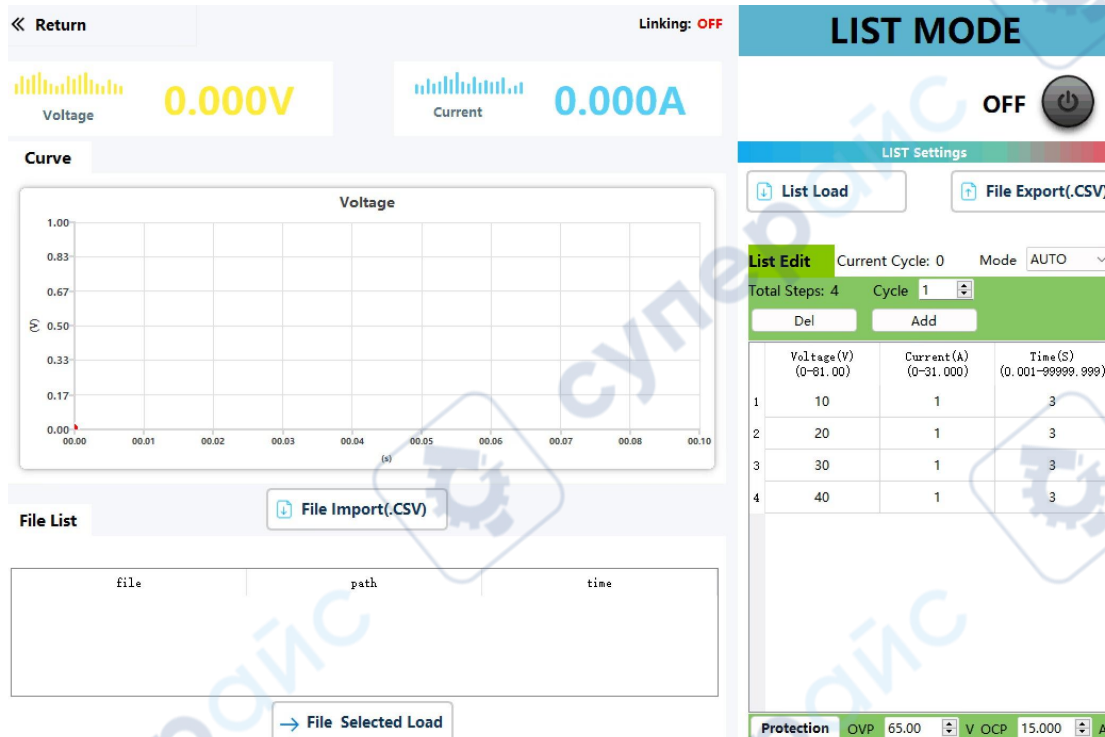

#### 4.6.3.3 PV Setup

The OWH67 series programmable DC power supply features P-V curve simulation capability, capable of simulating the IV output characteristics of various types of solar panels (monocrystalline, polycrystalline, thin-film) under different environmental conditions (including temperature, illumination, shading, degradation). It includes testing for Static MPPT efficiency and incorporates EN50530 and Sandia photovoltaic curve models. The standard photovoltaic curve simulation software can control multiple power supplies, enabling MPPT tracking testing. It provides testing and validation for grid-tied inverters, string inverters, PV-battery systems, and energy storage inverters, offering users an efficient testing solution.

---

Note: PV mode is an optional function. It is distinguished by the suffix band S of the model. If you are not clear, please consult our after-sales service or agents.

---

After setting the adjustable DC power supply to PV mode, clicking on the output settings will directly switch to the parameter setting interface of the PV

mode.

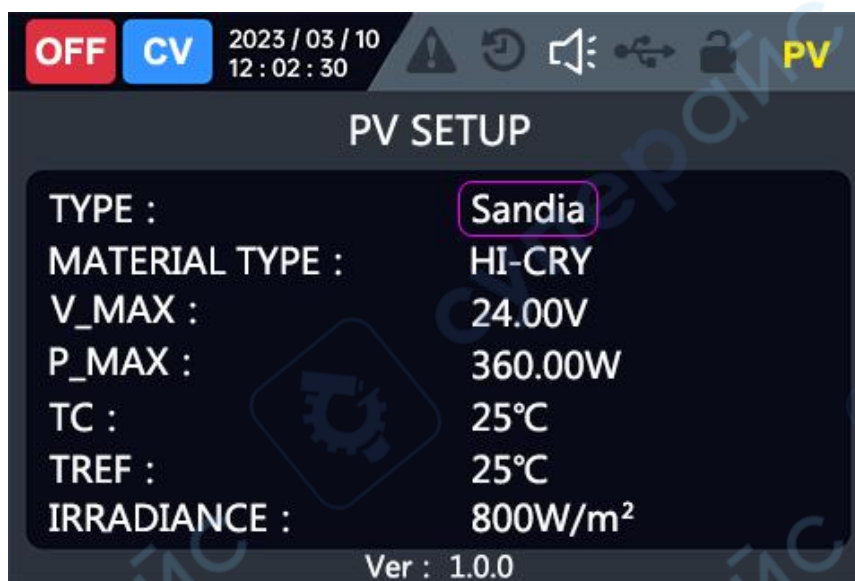

In the PV settings interface, users can conveniently configure PV curve types such as EN50530 and Sandia through the interface.

Users can set the PV curve by two ways: Create and import. To create a new PV curve, use the following steps:

- Type/Material type setting: Turn the **knob**, select the **TYPE** and **MATERIAL TYPE** in turn. Press **Enter** , **Esc** or **knob** to enter or exit editing. Select different curve types (EN50530, Sandia) and material types, and the setting interface will switch to the setting box of the corresponding curve. For example: Select the EN50530 curve type and material (THIN-FILM,c-Si), the corresponding parameters to be set include: maximum voltage, maximum power, test temperature (usually 25°C), ambient temperature, light intensity. Select the Sandia curve type and material (THIN\_FILM,STD-CRY, HI-CRY), the corresponding parameters to be set include: maximum voltage, maximum power, test temperature (usually 25°C), ambient temperature, light intensity.
- Set the maximum voltage: This maximum voltage is the maximum power point voltage of the simulated PV curve in volts.
- Set the maximum power: The maximum power is the maximum power

value corresponding to the PV curve under the test temperature (usually 25°C) and standard light intensity (1000W/m<sup>2</sup>).

- Test temperature: It is usually 25 °C and is used to provide standard PV curves.
- Ambient temperature: When the simulated PV is running, the actual ambient temperature, when the ambient temperature is different, the maximum voltage and maximum power of the PV curve are also different.
- Light intensity: When the simulated PV is running, the actual light intensity change, the value range is 0-1000 W/m<sup>2</sup>, the weaker the light, the smaller the output power.
- Press the **ON/OFF** to load curve: When the parameters of all steps are set, press the power button to run the PV curve.

For the complete function of PV, please use the host computer. Besides panel parameter setting, the host computer can also support the test of static MPPT. The home page of the host computer PV simulator is shown in the following figure.

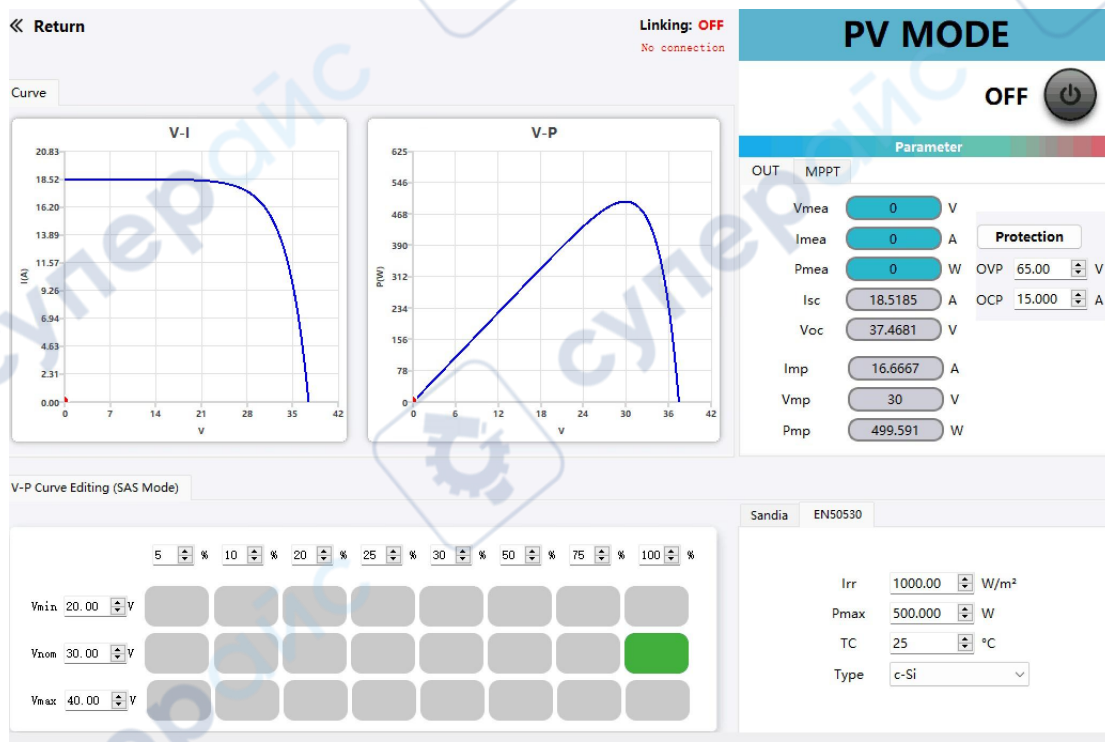

#### 4.6.3.4 APG Setup

The OWH67 series programmable DC power supply is equipped with a DB25 analog interface for APG (Analog interface programming). This analog interface has the following functions:

- Remote control the voltage/current value.
- Remote monitoring of CC and CV status, voltage and current values.

**Note:**

Before connecting the hardware device that controls the analog interface, make sure that the hardware device does not output a voltage higher than 20% of the specified value to the pin, or it will damage the instrument. For example, when the voltage is set to 10V, the input voltage must not exceed 12V, otherwise it will damage the instrument.

In analog remote-control mode, analog signal input pins cannot be suspended, and pins 21(VoL\_Pro) and 23(I\_Pro) need to be connected correctly before enabling the external analog function on the front panel.

The analog interface has safe electrical isolation from the DC terminal. Do not connect any ground wires of the analog interface to the DC+ or DC- terminals of the rear panel of the instrument.

The analog signal bandwidth is less than 10Hz, allowing arbitrary waveforms within this bandwidth. If the programmed signal frequency or amplitude exceeds the output capability, it will automatically limit the output amplitude. For input voltages exceeding 10V, the set value will be constrained within the maximum rated range.

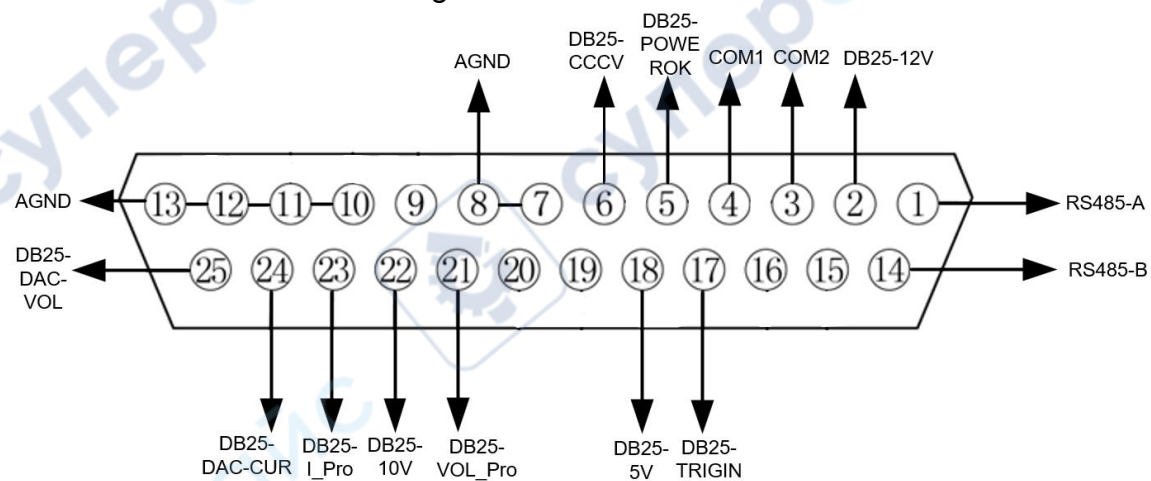

Table 4-5-3-4 DB25 analog interface pin description

Pin	Name	Type	Description
-----	------	------	-------------

1	RS485–A	Communication terminal	RS485 interface connection terminal.
14	RS485–B		
7,8,10-13	AGND	Grounding of analog signals	Ground all analog signals.
9,15,16,19,20	Not used	–	–
17	DB25-TRIGIN	Digital input signal	Trigger signal for LIST.
2	DB25-12V	Reference voltage	12V
18	DB25-5V	Reference voltage	5V
4	COM1	Numerically 1	Externally isolated digital signal input ground COM1.
3	COM2	Numerically 2	Externally isolated digital signal input ground COM2.
5	DB25-POWEROK	Output indicator signal	Output status indicator, normal output is HIGH, shutdown is LOW.
6	DB25-CCCV	I/O Output indicator signal	CCCV status indicator: CC: HIGH; CV: LOW
22	DB25-10V	Analog reference voltage	The 10V reference voltage output of the instrument itself can be connected to a resistor voltage divider for analog control.
21	DB25-VOL_Pro	Analog input	When in APG mode, voltage setting analog pin: used to set the voltage set value between 0 and full scale voltage.
23	DB25-I_Pro	Analog input	When in APG mode, current setting analog pin: used to set the current set value between 0 and full scale current.
25	DB25-DAC-VOL	Analog output	Monitor voltage, output 0~ 10V voltage value, used to monitor 0~ full range of DC terminal voltage.
24	DB25-DAC-CUR	Analog output	Monitor current, output 0~ 10V voltage value, used to monitor 0~ full scale DC output current.

### APG simulation interface control application detailed steps:

1. Press **CONF** key to enter system menu interface.

2. Turn the **knob** to select **MODE SETUP**, and press the **knob** or **Enter** key to enter the mode setting interface.

3. Turn the **knob** to select **APG MODE** and then press the **knob** or **Enter** to confirm.

4. Under APG mode, select **OUTPUT SETUP**, press the **knob** or **Enter** key to enter the APG relative setting interface.

- Turn the **knob** and select the drop-down option boxes **Enable** and **Disable** to enable and disable the VSET/ISET/VMEAS/IMEAS functions of the APG function. Note: Before enable VSET/ISET function, please confirm pin 21 and 23 is connected correctly.

5. Press **Esc** to exit menu interface.

### Analog interface remote control

Through the analog input interface, the output voltage or current value can be set remotely by inputting analog signals. See Table 4-5-3-4 DB25 Analog Interface Description for detailed pin functional definitions. The following commonly used voltage and current control to introduce how to wire, and how to use.

When voltage and current set points are controlled through the analog interface, an external voltage (0V to 10V) is connected to program voltage or current values between 0 and full scale. At the same time, the analog monitoring function (0V ~ 10V) can be used to monitor the current voltage or current between 0 and full scale. For example, with an analog control range of 0 to 30A current, when the analog signal voltage is set to 5V, the output of the instrument is 15A. When the analog signal voltage is set to 8V, the output of the instrument is 24A. The wiring method is as it follows.

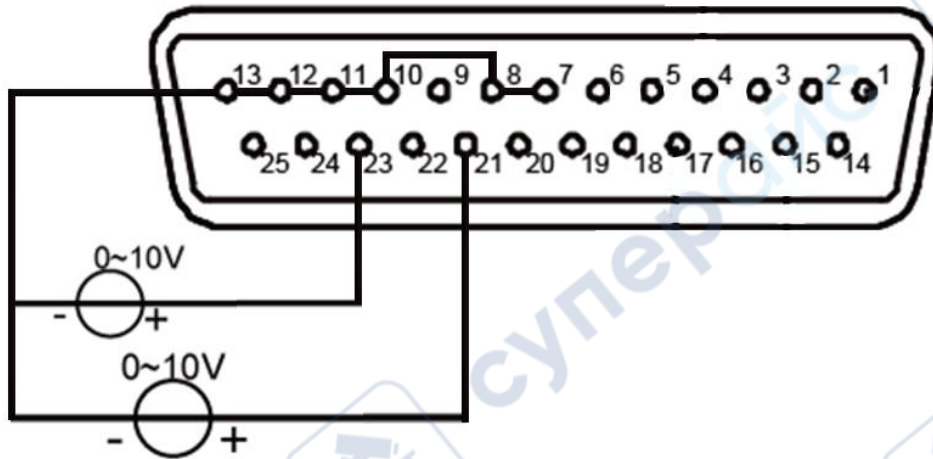

- Monitor voltage/current

The current output voltage/current or input voltage/current can be monitored through the analog interface. A digital voltmeter is connected between pins 25 (DB25-DAC-VOL), 24 (DB25-DAC-CUR) and ground 7,8,10-13 (AGND) of the analog quantity interface. The voltage readings from 0 to 10V correspond to the zero to full scale voltage current output/input of the power supply/load, the wiring method is as follows.

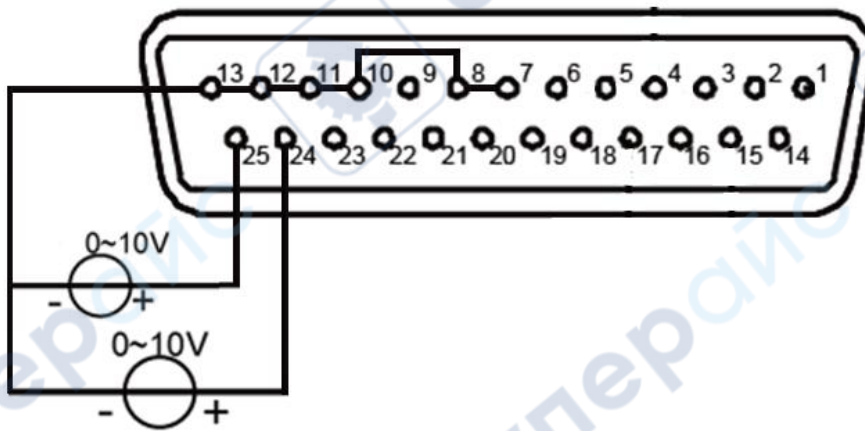

#### 4.6.4 Protect Setup

OWH67 series products can flexibly set OVP (Over-Voltage Protection), OCP (Over-Current Protection), OPP (Over Power Protection) functions according to user need. For example, OWH67012-80, OVP can be set to 1-85V, OCP can be set to 1A-35A, and OPP can be set to a minimum of 10W and a maximum of 1300W.



#### 4.6.5 Remote Setup

OWH67 series products are equipped with a variety of communication interface, USB serial port, RS485 and LAN functions. LAN function belongs to the optional, through the model suffix band L to make a distinction, if not clear, you can contact and ask the sales staff at any time.

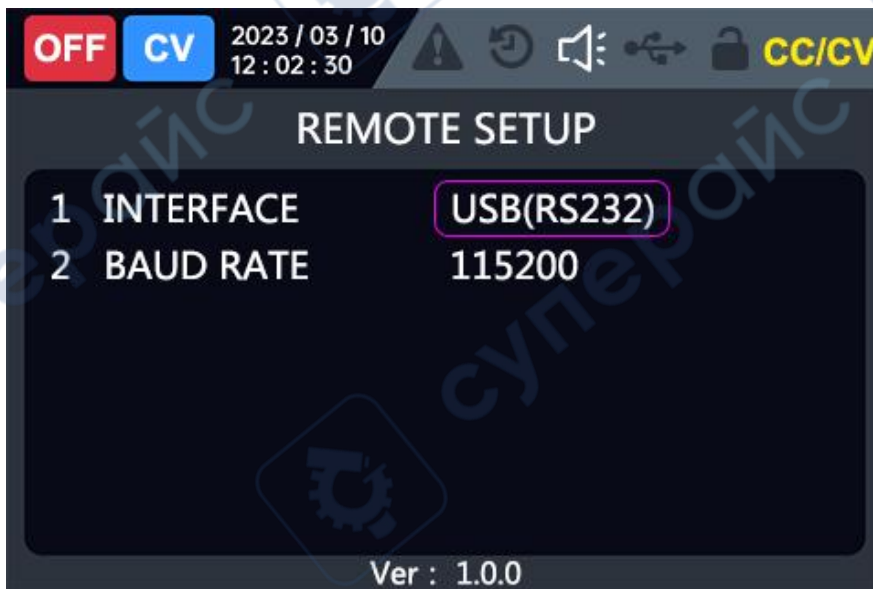

RS485 is DB9 terminal:

Pin	Function
Pin 2	RS485_A

Pin3	RS485_B
Pin1,4,5,6,7,8,9	NC

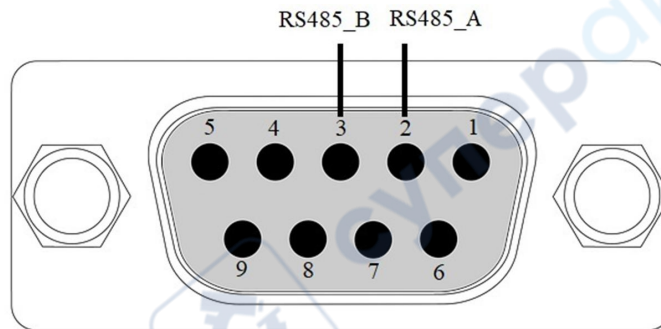

#### 4.6.6 Series/Parallel Setup

##### 4.5.6.1 Series/Parallel function

OWH67 series products can be in series/parallel operation, when in series mode, the voltage can reach up to 300V; when in parallel mode, the maximum current can reach 300A.



**Note:**

1. Series and parallel cannot be mixed.
2. OWH67 series products in series or parallel operation, the maximum output voltage is 600V or the maximum output current is 300A, as shown in the table below.

Model	Series mode		Parallel mode	
	Maximum number	Maximum voltage	Maximum number of combinations	Maximum current
<b>OWH67020-600</b>	2	600V	10	100A
<b>OWH67030-600</b>	2	600V	10	100A
<b>OWH67012-300</b>	2	600V	10	100A
<b>OWH67020-300</b>	2	600V	10	100A
<b>OWH67030-300</b>	2	600V	10	150A
<b>OWH67012-150</b>	4	600V	10	200A
<b>OWH67018-150</b>	4	600V	10	300A
<b>OWH67020-150</b>	4	600V	10	200A
<b>OWH67030-150</b>	4	600V	10	300A
<b>OWH67012-80</b>	7	560V	10	300A

3. Series/parallel operation is not allowed for different models.

4. When use series/parallel operations, ensure that the circuit breaker capacity is sufficient, and that the ground of the power cable is connected to the same point and grounded.

5. When the number of parallel units is greater than 3, please consult our customer service or nearby agents.

6. Series/parallel connection, please make sure that the remote sensing connection is correct.

#### **4.5.6.2 Series/Parallel output line connection**

The setting of the output terminals to the DUT for series connection mode is shown in the following figure.

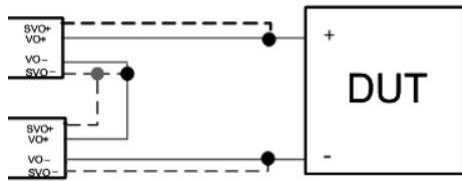

The setting of the output terminals to the DUT for parallel connection mode is shown in the following figure.

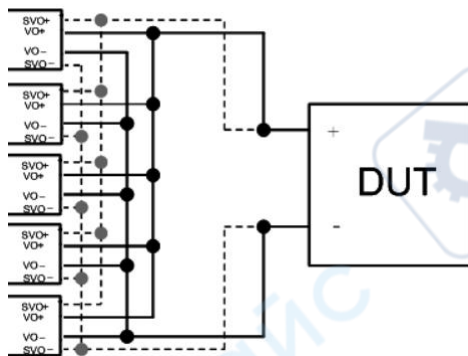

#### 4.5.6.3 Series/Parallel communication interface Connection



#### 4.5.6.4 Series/Parallel system operation

##### 1、SLAVE setup

**Note:**For the OWH67 series operation in series/parallel mode, set SLAVE first and MASTER last. Otherwise, communication errors may occur and the operation cannot be performed.

- Parallel mode: SERIES/PARALLEL
- Master/slave optional: MASTER/SLAVE
- Parallel control: ENABLE/DISABLE
- Parallel state
- Slave number
- The SLAVE needs to select the slave from the master and slave, and enable parallel operation at the same time.

- Parallel control enabled, not editable parallel and master-slave mode, only readable function.

## 2、MASTER setup

**Note:**For the OWH67 series operation in series/parallel mode, set SLAVE first and MASTER last. The system can only have one host. Otherwise, communication errors may occur and the system cannot operate.

- Parallel mode: SERIES/PARALLEL
- Master/slave optional: MASTER/SLAVE
- Parallel control: ENABLE/DISABLE
- Parallel state
- Slave number

The MASTER needs to select master from the master and slave, enable the parallel function at the same time, and set the total voltage and current on the host interface.

Note: The OVP and OCP settings of the host correspond to the OVP of the system and system OVP and OCP is online number N time host's OVP and OCP. For example, in series mode, set the host computer OVP to 80V, the number of online systems is 2 (means that N=2), the system OVP is  $80V \times 2=160V$ . Under parallel mode, set the host computer OCP to 30A, the number of online systems is 3, the system OCP is  $30A \times 3=90A$ .

### 4.6.7 System Setup

The screen displays the model, version, serial, and checksum of the machine.

### 4.6.8 Fault Information

The OWH67 series products provide real-time monitoring of internal operations, including system logic faults, external AC power failures, internal power stage faults, output overvoltage and overcurrent faults, as well as parallel operation faults. Users can check the status of each module by accessing the "Settings / Fault Information" menu. If there are no faults, it will display "Normal"; if there are faults, it will display "Error" along with the corresponding fault code.

Fault Type	ERROR CODE	Fault cause Description
------------	------------	-------------------------

MAINS AC FAULT	0x0001	Abnormal power loss
	0x0002	Abnormal mains undervoltage
	0x0004	Abnormal mains overvoltage
INTERNAL FAULT1	0x0001	Internal PFC bus overvoltage
	0x0002	Internal PFC bus undervoltage
	0x0004	Bias anomaly in the internal bus
	0x0008	An overcurrent in the internal rectifier circuit
INTERNAL FAULT2	0x0002	Internal logic power supply 5V abnormal
	0x0004	Abnormal heat sink overtemperature
	0x0008	Internal overcurrent anomaly
	0x0010	Error in internal parameter storage
	0x0020	Model firmware match error
OUTPUT FAULTS	0x0002	Output over voltage protection
	0x0004	Output remote compensation anomaly (short circuit or reverse connection)
	0x0008	Output over current protection
	0x0010	Output over power protection
	0x0020	Internal output overvoltage
SERIES/PARALLEL	0x0002	Abnormal setting of parallel system parameters (such as serial/parallel mode inconsistency)
	0x0004	Multihost error in the parallel system
	0x0008	CAN communication dropped
COMM FAULTS	0x0001	Host computer communication timeout or disconnection
INPUT POWER LIMIT	0x0001	Warning:Insufficient input power

## 4.7 Waveform display Function

OWH67 series product provides local waveform real-time visual display function, can visually read the current voltage and current and a period of time curve state.

Setting mode:

1. Press **DISP** to enter waveform display interface.
2. Press **DISP** again or press **Esc** key to exit and return to the user interface.

## 4.8 Remote Measurement Function

When the OWH67 series power supply is in working condition, when the power supply outputs a large current or the wire is long, it will produce a large

voltage drop on the connection line between the measured instrument and the power terminal. In order to ensure the measurement accuracy, the power supply provides a remote compensation terminal in the back panel, and the user can use the terminal to measure the output terminal voltage of the measured instrument.

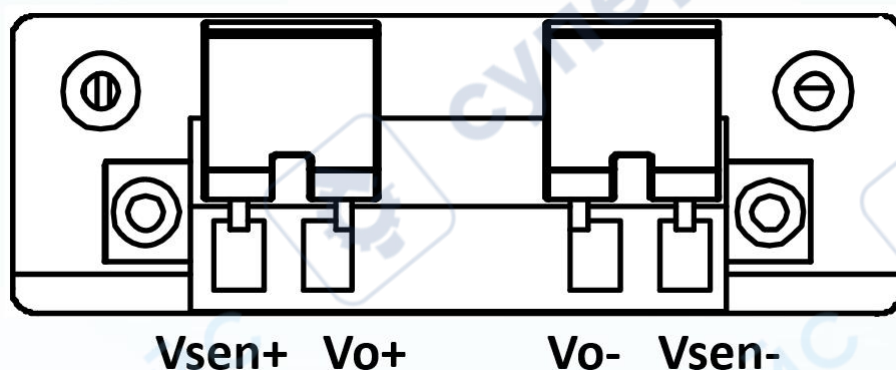

- Vsen+, Vsen-: Remote measuring terminal;
- Vo+,Vo-: The output terminal is the same as the output terminal of the front panel.

**Use local measurements:**

The local measurement does not compensate for the voltage drop on the wire and operates as it follows:

1. Install wires directly between Vo+, Vsen+ and Vo-, Vsen-.
2. The front panel outputs the positive and negative terminals or the back panel Vo+, and the Vo -terminals are directly connected to the device under test with a wire.

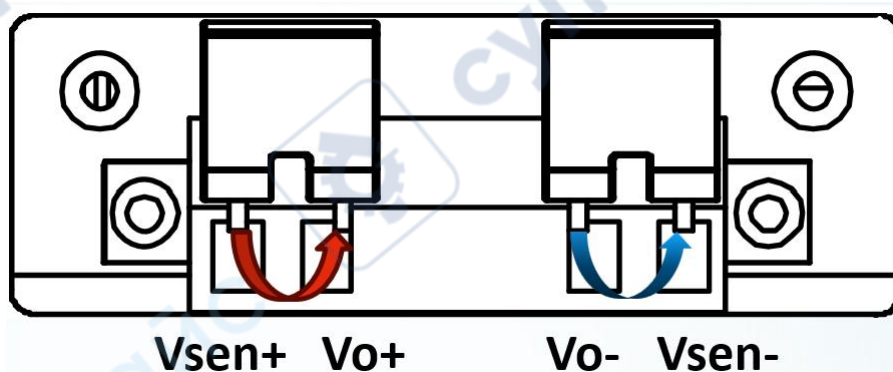

**Use remote measurements:**

The remote metering function allows compensating voltage drops across the power supply output terminal and the wire before the device under test. Do the following:

1. Remove any jumpers or short-circuit clips of  $V_{o+}$ ,  $V_{sen+}$ ,  $V_{o-}$ ,  $V_{sen-}$  on the rear panel terminals;
2. Connect a corresponding inductive wire from  $V_{sen+}$  and  $V_{sen-}$  to the device under test;
3. Connect a pair of drive power supply wires to the front panel terminal or the back panel terminal  $V_{o+}$ ,  $V_{o-}$ , and the remote compensation wiring is shown below.

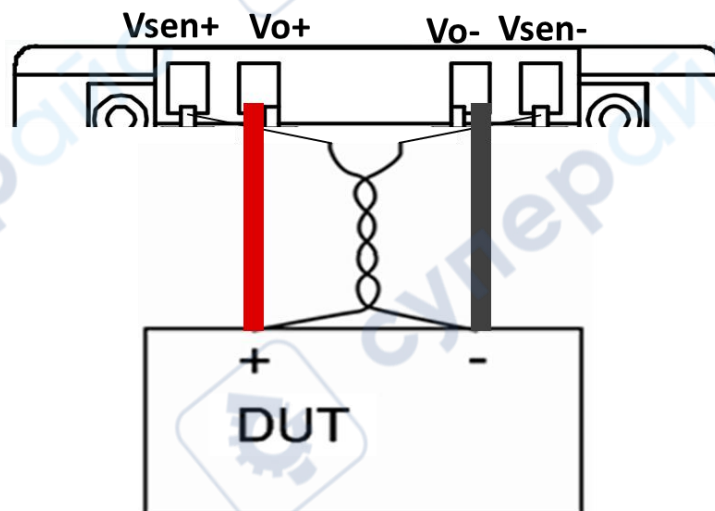

---

**Note:**

1. In order to ensure the stability of the system, please use the armored twisted-pair cable before the remote measurement and load of the OWH67 series power supply. Please pay attention to the positive and negative polarity of the wiring, which may bring output failure and even damage the instrument.

2. Without using sense function, please do not leave the sensing pin floating, otherwise the output may be very inaccurate.

---

## 5. Troubleshooting

1. **The instrument is powered on but no display. Please following the steps:**

- Check if the power is connected properly.
- Check if the fuse which is below the AC Power socket is used appropriately and in good condition (the cover can be pried open with a straight screwdriver).
- Restart the instrument after the steps above.
- If the problem still exists, please contact our customer service.

## 6. Technical Specification

The instrument must be operated continuously for more than 30 minutes at the specified operating temperature to achieve the following specifications:

Model	OWH 67012-80	OWH 67012-150	OWH 67012-300	OWH 67018-150	OWH 67020-150	OWH 67020-300	OWH 67020-600	OWH 67030-150	OWH 67030-300	OWH 67030-600	
Rated Output (0°C-40°C)	Voltage	0-80V	0-150V	0-300V	0-150V	0-150V	0-300V	0-600V	0-150V	0-300V	0-600V
	OVP	1-85V	1-155V	1-305V	1-155V	1-155V	1-305V	1-605V	1-155V	1-305V	1-605V
	Current	0-30A	0-20A	0-10A	0-30A	0-20A	0-10A	0-10A	0-30A	0-15A	0-10A
	OC P	1-35A	1-25A	1-15A	1-35A	1-25A	1-15A	1-11A	1-35A	1-20A	1-11A
	Power	1200W			1800W	2000W			3000W		
OPP	10W - 1300W			10W - 1900W	10W-2100W			10W - 3100W			
Power supply	85V-265Vac; 50Hz-60Hz,10A Max							85V-265Vac; 50Hz-60Hz,16A Max			
Load Regulation (%of output+offset)	CV	$\leq 0.03\% + 10mV$									
	CC	$\leq 0.05\% + 30mA$									
Line Regulation (%of output+offset)	CV	$\leq 0.01\% + 10mV$									
	CC	$\leq 0.05\% + 20mA$									
Setting Resolution	Voltage	10mV									
	Current	1mA									
Reack Resolution	Voltage	1mV									
	Current	1mA									
Setting Accuracy	Voltage	$\leq 0.05\% \pm 20mV$	$\leq 0.05\% \pm 20mV$	$\leq 0.05\% \pm 50mV$	$\leq 0.05\% \pm 20mV$	$\leq 0.05\% \pm 20mV$	$\leq 0.05\% \pm 50mV$	$\leq 0.05\% \pm 100mV$	$\leq 0.05\% \pm 20mV$	$\leq 0.05\% \pm 50mV$	$\leq 0.05\% \pm 100mV$
	Current	$\leq 0.05\% \pm 30mA$	$\leq 0.05\% \pm 20mA$	$\leq 0.05\% \pm 20mA$	$\leq 0.05\% \pm 20mA$	$\leq 0.05\% \pm 20mA$	$\leq 0.05\% \pm 20mA$	$\leq 0.05\% \pm 20mA$	$\leq 0.05\% \pm 30mA$	$\leq 0.05\% \pm 20mA$	$\leq 0.05\% \pm 20mA$
Reack Accuracy	Voltage	$\leq 0.05\% \pm 20mV$	$\leq 0.05\% \pm 20mV$	$\leq 0.05\% \pm 50mV$	$\leq 0.05\% \pm 20mV$	$\leq 0.05\% \pm 20mV$	$\leq 0.05\% \pm 50mV$	$\leq 0.05\% \pm 100mV$	$\leq 0.05\% \pm 20mV$	$\leq 0.05\% \pm 50mV$	$\leq 0.05\% \pm 100mV$
	Current	$\leq 0.05\% \pm 30mA$	$\leq 0.05\% \pm 30mA$	$\leq 0.05\% \pm 20mA$	$\leq 0.05\% \pm 30mA$	$\leq 0.05\% \pm 20mA$	$\leq 0.05\% \pm 20mA$	$\leq 0.05\% \pm 20mA$	$\leq 0.05\% \pm 30mA$	$\leq 0.05\% \pm 20mA$	$\leq 0.05\% \pm 20mA$
Ripple	Volt	$\leq 100mVp-p$	$\leq 100mVp-p$	$\leq 250mVp-p$	$\leq 100mVp-p$	$\leq 100mVp-p$	$\leq 200mVp-p$	$\leq 500mVp-p$	$\leq 100mVp-p$	$\leq 250mVp-p$	$\leq 500mVp-p$

e/No ise (*)	age Curr ent	≤50mArms	≤50mArms	≤ 50mArms	≤50mArms	≤30mArms	≤50mArms	≤ 50mArms	≤50mArms	≤50mArms	≤50mArms
Outp ut temp eratu re coeff icien t	Volt age	100ppm/°C									
(0°C- 40°C )	Curr ent	200ppm/°C									
Rea dbac k temp eratu re coeff icien t	Volt age	100ppm/°C									
	Curr ent	200ppm/°C									
Recovery Time (10%- 90% rated load)		5ms									
Working Temperat ure		0-40°C									
Display Interface		3.9 inch color LCD display									
		USB, RS485, LAN(Optional)									
Size		214.6 mm(W) X 88.0 mm(H) X 453.0 mm(D)									
Weight		Approx. 6.4kg					Approx. 6.8kg				

### Interval Period of Adjustment:

One year is recommended for the calibration interval period.

## 7. Appendix

### 7.1 Appendix A: Accessories

(The accessories subject to final delivery.)

#### Standard



Power Cord



User Manual



USB Cable

#### Optional



Banana plug to  
alligator clip  
cable



L-shaped  
fixed bracket

### 7.2 Appendix B: General Care and Cleaning

#### General Care

Do not store or leave the instrument where the liquid crystal display could be exposed to direct sunlight for long periods of time.

**Caution:** To avoid any damage to the instrument, do not exposed it to any sprays, liquids, or solvents.

#### Cleaning

Inspect the instrument as often as operating conditions require. To clean the instrument exterior, perform the following steps:

1. Wipe the dust from the instrument surface with a soft cloth. Take care not to scratch the transparent LCD protection screen when cleaning.

2. Disconnect power before cleaning your instrument. Clean the instrument with a damp soft cloth (not dripping with water). It is recommended to clean with soft detergent or fresh water. To avoid damage to the instrument, do not use any corrosive chemical cleaning agents.

---

 **Warning:**

Before re-applying power, ensure that the instrument is completely dry, avoiding any electric shock or electrical short circuit resulting from moisture.

---