

ALTERA®

USB-Blaster Download Cable

User Guide

ALTERA®

UG-USB81204-2.5
P25-10325-03

Software Version: 9.0
Document Version: 2.5
Document Date: © April 2009

Copyright © 2009 Altera Corporation. All rights reserved. Altera, The Programmable Solutions Company, the stylized Altera logo, specific device designations, and all other words and logos that are identified as trademarks and/or service marks are, unless noted otherwise, the trademarks and service marks of Altera Corporation in the U.S. and other countries. All other product or service names are the property of their respective holders. Altera warrants performance of its semiconductor products to current specifications in accordance with Altera's standard warranty, but reserves the right to make changes to any products and services at any time without notice. Altera assumes no responsibility or liability arising out of the application or use of any information, product, or service described herein except as expressly agreed to in writing by Altera Corporation. Altera customers are advised to obtain the latest version of device specifications before relying on any published information and before placing orders for products or services.

Chapter 1. Setting Up the USB-Blaster Download Cable

Introduction	1-1
Supported Devices	1-1
Power Requirements	1-1
Software Requirements	1-2
Hardware Setup	1-2
Software Setup	1-3
Installing the USB-Blaster Driver on Windows 2000 and Windows XP Systems	1-4
Installing the USB-Blaster Driver on Windows Vista Systems	1-4
Installing the USB-Blaster Driver on Linux	1-5
Setting Up the USB-Blaster Hardware in the Quartus II Software	1-6

Chapter 2. USB-Blaster Specifications

Overview	2-1
USB-Blaster Connections	2-1
Voltage Requirements	2-1
Cable-to-Board Connection	2-2
USB-Blaster Plug Connection	2-3
Circuit Board Header Connection	2-4
Operating Conditions	2-5
USB-Revision	2-7
Statement of China-RoHS Compliance	2-8
References	2-8

Additional Information

Revision History	About-1
How to Contact Altera	About-2
Typographic Conventions	About-2

List of Figures

Figure 1-1: The USB-Blaster Download Cable	1-3
Figure 1-2: Hardware Setup Dialog Box	1-6
Figure 2-1: USB-Blaster Block Diagram	2-2
Figure 2-2: USB-Blaster Dimension	2-3
Figure 2-3: USB-Blaster 10-Pin Female Plug Dimensions	2-3
Figure 2-4: 10-Pin Male Header Dimensions	2-4

List of Tables

Table 1-1: Programming Modes	1-7
Table 2-1: USB-Blaster VCC(TRGT) Pin Voltage Requirements	2-1
Table 2-2: USB-Blaster Female Plug Signal Names & Programming Modes	2-4
Table 2-3: USB-Blaster Cable Absolute Maximum Ratings	2-5
Table 2-4: USB-Blaster Cable Recommended Operating Conditions	2-5
Table 2-5: USB-Blaster Cable (Rev. A & B) DC Operating Conditions	2-5
Table 2-6: USB-Blaster Cable (Rev. C) DC Operating Conditions	2-6
Table 2-7: USB-Revision	2-7
Table 2-8: Table of Hazardous Substances' Name and Concentration.....	2-8

Introduction

The USB-Blaster™ download cable interfaces a USB port on a host computer to an Altera® FPGA mounted on a printed circuit board. The cable sends configuration data from the PC to a standard 10-pin header connected to the FPGA. You can use the USB-Blaster cable to iteratively download configuration data to a system during prototyping or to program data into the system during production.

Supported Devices

You can use the USB-Blaster download cable to download configuration data to the following Altera devices:

- Stratix® series FPGAs
- Cyclone® series FPGAs
- MAX® series CPLDs
- Arria® GX series FPGAs
- APEX™ series FPGAs
- ACEX® 1K FPGAs
- Mercury™ FPGAs
- FLEX 10K® series FPGAs
- Excalibur™ FPGAs

You can perform in-system programming of the following devices:

- Altera configuration devices including EPC2 devices.
- Enhanced configuration devices including EPC4, EPC8, and EPC16 devices.
- Serial configuration devices including EPCS1, EPCS4, EPCS16, EPCS64, and EPCS128 devices.

In addition, you can perform SignalTap® II logic analysis.

The USB-Blaster download cable supports target systems using 5.0-V TTL, 3.3-V LVTTTL/LVCMOS, and single-ended I/O standards from 1.5 V to 3.3 V.

Power Requirements

The USB-Blaster download cable requires the following power sources:

- 5.0 V from the USB cable
- Between 1.5 V and 5.0 V from the target circuit board

Software Requirements

The USB-Blaster download cable is only available for Windows 2000, Windows XP (32-bit and 64-bit), Windows Vista (32-bit and 64-bit), UNIX and all Linux platforms such as Red Hat Enterprise 4, Red Hat Enterprise 5, CentOS 4/5, and SUSE Linux Enterprise 9.

 For Quartus operating system support, refer [Operating System Support](#).

Use the Quartus[®] II software version 4.0 or later to configure your device. The USB-Blaster download cable also supports the following:

- Quartus II Programmer (for programming and configuration)
- Quartus II SignalTap[®] II Logic Analyzer (for logic analysis)
- Quartus II Programmer (standalone version)
- Quartus II SignalTap II logic analyzer (standalone version)

Hardware Setup

This section describes how to install and set up the USB-Blaster download cable for device configuration or programming.

 For plug and header dimensions, pin names, and operating conditions, see [Chapter 2, USB-Blaster Specifications](#).

Connect your USB-Blaster download cable to the circuit board as instructed below.

1. Disconnect the power cable from the circuit board.
2. Connect the USB cable to the USB port on your PC and to the USB-Blaster port.
3. Connect the USB-Blaster download cable to the 10-pin header on the device board. [Figure 1-1](#) shows the USB-Blaster download cable and the circuit board connector.



To avoid damaging the USB-Blaster cable, first unplug the cable from the 10-pin header on the target board before unplugging the cable from the USB port on your PC. It is safest to remove power first from the target board before unplugging the USB-Blaster cable. For more information, refer to [USB Blaster errata sheet](#).

Figure 1-1. The USB-Blaster Download Cable

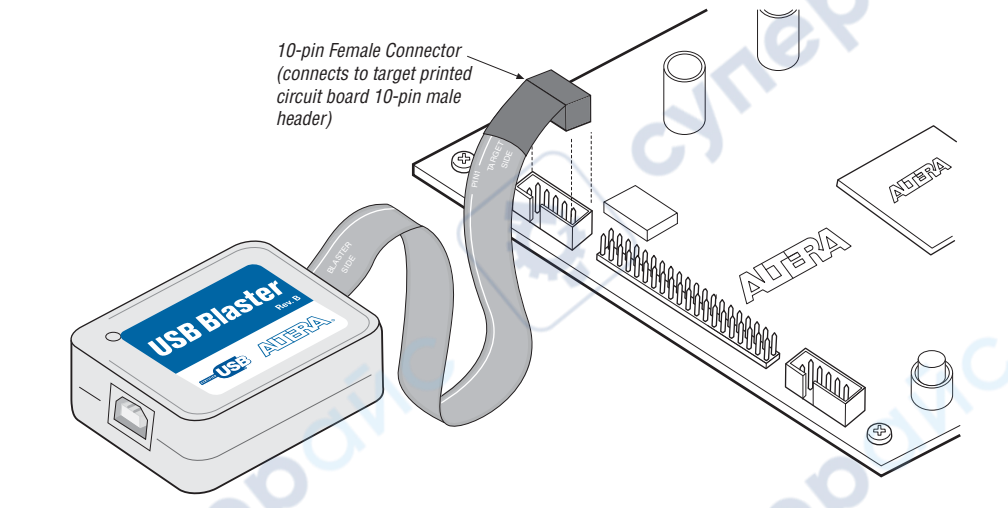

4. Reconnect the power cable to reapply power to the circuit board.



The **Found New Hardware** wizard may open and prompt you to install a new hardware driver. Close the wizard and install the hardware driver using the instructions provided in [“Software Setup”](#) on page 1-3.

Software Setup

This section describes the following:

- [“Installing the USB-Blaster Driver on Windows 2000 and Windows XP Systems”](#)
- [“Installing the USB-Blaster Driver on Windows Vista Systems”](#)
- [“Installing the USB-Blaster Driver on Linux”](#)
- [“Setting Up the USB-Blaster Hardware in the Quartus II Software”](#)

Installing the USB-Blaster Driver on Windows 2000 and Windows XP Systems

This section describes how to install the USB-Blaster driver on Windows 2000 and Windows XP systems.

Before you begin the installation, verify the USB-Blaster driver is located in your directory: \<Quartus II system directory>\drivers\usb-blaster



If the driver is not in your directory, download the USB-Blaster driver from the Altera web site: www.altera.com/support/software/drivers

To install the driver, follow the directions below:

1. Plug in the USB-Blaster download cable to the PC.
2. On the Found New Hardware Wizard window, click **No, not this time** and then click **Next** to continue.
3. Select **Install from a list of specific location (Advanced)** and click **Next** to continue.
4. Select **Don't search. I will choose the driver to install**. Click **Next**.
5. Select **Sound, video and game controllers**, and click **Next** to continue.
6. Select **Have Disk** and browse to the location of the driver on your system: \<Quartus II system directory>\drivers\usb-blaster. Click **OK**.
7. Select **Altera USB-Blaster** and click **Next** to continue.
8. Click **Next** to install the driver.
9. Click **Continue Anyway** when the Hardware Installation warning appears.
10. Click **Finish** in the Completing the Add/Remove Hardware Wizard window. Reboot your system.

Installing the USB-Blaster Driver on Windows Vista Systems

This section describes how to install the USB-Blaster driver on Windows Vista systems.

Before you begin the installation, verify that the USB-Blaster driver is located in your directory: \<Quartus II system directory>\drivers\usb-blaster



If the driver is not in your directory, download the USB-Blaster driver from the Altera web site: www.altera.com/support/software/drivers

To install the driver, follow the directions below:

1. Plug in the USB-Blaster download cable to the PC.
2. On the Found New Hardware Wizard window, click **Locate and install driver software** to continue.
3. On the Found New Hardware - USB-Blaster window, click **I don't have the disk. Show me other options** to continue.
4. Click **Browse my computer for driver software** to continue.

5. Click **Browse...** and browse to the location of the driver on your system: `\<Quartus II system directory>\drivers\usb-blaster`. Click **OK**.
6. Click **Next** to install the driver.
7. Click **Install this driver software anyway** when the Hardware Installation warning appears.
8. Click **Close** when the driver installation is completed. Reboot your system.

Installing the USB-Blaster Driver on Linux

This section describes how to install the USB-Blaster driver on Linux.

The Quartus II software uses the built-in USB drivers (usbfs) on RedHat Linux to access the USB-Blaster download cable. By default, *root* is the only user allowed to use usbfs. You must change the permission on the ports before you can use the USB-Blaster download cable to program devices with the Quartus II software.

You must have system administration (root) privileges to configure the USB-Blaster download cable drivers.

For Red Hat Enterprise 4 and earlier versions

1. Add the following lines to the `/etc/hotplug/usb.usermap` file.

```
#  
# Altera USB-Blaster  
#  
usbblaster 0x03 0x09fb 0x6001 0x0 0x0 0x0 0x0 0x0 0x0 0x0 0x0 0x0  
usbblaster 0x03 0x09fb 0x6002 0x0 0x0 0x0 0x0 0x0 0x0 0x0 0x0 0x0  
usbblaster 0x03 0x09fb 0x6003 0x0 0x0 0x0 0x0 0x0 0x0 0x0 0x0 0x0
```

2. Create a file named `/etc/hotplug/usb/usbblaster` and add the following lines to it.

```
#!/bin/sh  
# USB-Blaster hotplug script  
# Allow any user to access the cable  
chmod 666 $DEVICE
```

3. Make the file executable.
4. Complete your installation by setting up the programming hardware in the Quartus II software as described in the following section.

 Refer to www.altera.com/support/software/drivers for more information on USB-Blaster driver installation.

For Red Hat Enterprise 5

1. Create a file named `/etc/udev/rules.d/51-usbblaster.rules` and add the following lines to it. Take note that after `#USB-Blaster`, all code must be in one line.

```
# USB-Blaster
BUS=="usb", SYSFS{idVendor}=="09fb", SYSFS{idProduct}=="6001",
MODE="0666", PROGRAM="/bin/sh -c 'K=%k; K=${K#usbdev}; printf
/proc/bus/usb/%03i/%03i ${K%%.*} ${K#*}'", RUN+="/bin/chmod 0666
%c"
```

2. Complete your installation by setting up the programming hardware in the Quartus II software as described in the “[Setting Up the USB-Blaster Hardware in the Quartus II Software](#)”.



For more information about USB-Blaster driver installation, refer to www.altera.com/support/software/drivers.

Setting Up the USB-Blaster Hardware in the Quartus II Software

Use the following steps to set up the USB-Blaster hardware in the Quartus II software:

1. Start the Quartus II software.
2. Choose **Programmer** (Tools menu).
3. Click **Hardware Setup**. The **Hardware Settings** tab of the **Hardware Setup** dialog box is displayed (Figure 1-2).

Figure 1-2. Hardware Setup Dialog Box

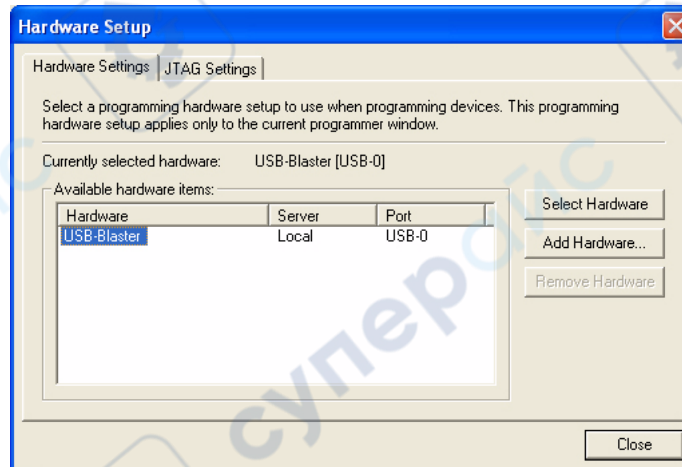

4. From the drop-down menu, select **USB-Blaster [USB-0]** (Figure 1-2).
5. Click **Close** to close the **Hardware Setup** dialog box.
6. In the **Mode** list, select the desired mode (Programmer window). [Table 1-1](#) describes each mode.



The USB-Blaster supports the Joint Test Action Group (JTAG), Passive Serial Programming, and Active Serial modes.

Table 1-1. Programming Modes

Mode	Mode Description
Joint Test Action Group (JTAG)	Programs or configures all Altera devices supported by Quartus II software, excluding FLEX 6000 and EPCS serial configuration devices.
In-Socket Programming	Not supported by the USB-Blaster.
Passive Serial Programming	Configures all Altera devices supported by Quartus II software excluding MAX 3000, MAX 7000, MAX II, EPC enhanced configuration devices, and EPCS serial configuration devices.
Active Serial Programming	Programs a single EPCS1, EPCS4, EPCS16, EPCS64, or EPCS128 serial configuration device.

For details about programming devices and creating secondary programming files, see the *Programming & Configuration* chapter of the *Introduction to Quartus II Handbook*.

For details about the Quartus II Programmer, refer to the *Quartus II Programmer* chapter in volume 3 of the *Quartus II Handbook*.

For more information, refer to the Programming module of the Quartus II software online tutorial and the following topics in the Quartus II Help:

- Changing the Hardware Setup
- Programmer Introduction
- Overview: Working with Chain Description Files
- Overview: Converting Programming Files

Overview

This chapter provides comprehensive information about the USB-Blaster™ download cable including the following:

- “USB-Blaster Connections” on page 2-1
 - “Voltage Requirements” on page 2-1
 - “Cable-to-Board Connection” on page 2-2
 - “USB-Blaster Plug Connection” on page 2-3
 - “Circuit Board Header Connection” on page 2-4
- “Operating Conditions” on page 2-5
- “USB-Revision” on page 2-7
- “Statement of China-RoHS Compliance” on page 2-8

USB-Blaster Connections

The USB-Blaster cable has a USB universal plug that connects to the PC USB port, and a 10-pin female plug that connects to the circuit board. Data is downloaded from the USB port on the PC through the USB-Blaster cable to the circuit board via the connections discussed in this section.

Voltage Requirements

The USB-Blaster VCC (TRGT) pin must be connected to a specific voltage for the device being programmed. Connect pull-up resistors to the same power supply as the USB-Blaster V_{CC}(TRGT). See [Table 2-1](#).

Table 2-1. USB-Blaster VCC(TRGT) Pin Voltage Requirements (Part 1 of 2)

Device Family	USB-Blaster VCC Voltage Required
MAX® II devices	As specified by V _{CCIO} of Bank 1
MAX 7000S device	5 V
MAX 7000AE and MAX 3000A devices	3.3 V
MAX 7000B devices	2.5 V
Arria II GX devices	As specified by V _{CCPD} or V _{CCIO} of Bank 8C
Stratix III and Stratix IV devices	As specified by V _{CCPGM} or V _{CCPD}
Cyclone® III devices	As specified by V _{CCA} or V _{CCIO}
Stratix II, Stratix, Stratix II GX, Stratix GX, and Arria GX devices	As specified by V _{CCSEL}

Table 2-1. USB-Blaster VCC(TRGT) Pin Voltage Requirements (Part 2 of 2)

Device Family	USB-Blaster VCC Voltage Required
Cyclone II, Cyclone, APEX II, APEX 20K, and Mercury devices	As specified by V_{CCIO}
FLEX 10K, FLEX 8000, and FLEX 6000 devices	5 V
FLEX 10KE device	2.5 V
FLEX 10KA and FLEX 6000A devices	3.3 V
EPC2 devices	5 V or 3.3 V
EPC4, EPC8, and EPC16 devices	3.3 V
EPCS1, EPCS4, EPCS16, EPCS64, and EPCS128 devices	3.3 V

Cable-to-Board Connection

A standard USB cable connects to the USB port on the device. Figure 2-1 shows a block diagram of the USB-Blaster download cable.

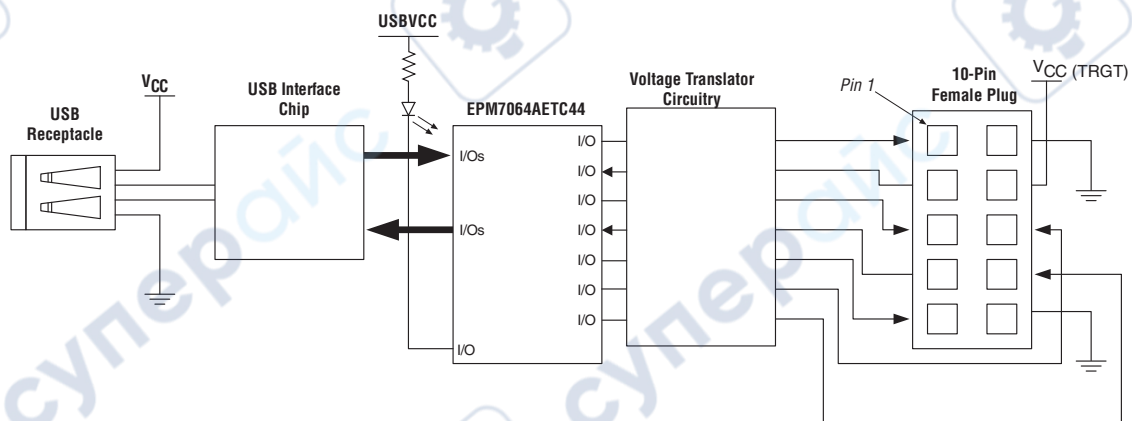
Figure 2-1. USB-Blaster Block Diagram

USB-Blaster Plug Connection

The 10-pin female plug connects to a 10-pin male header on the circuit board containing the target device. [Figure 2-2](#) shows the dimensions of the USB-Blaster, and [Figure 2-3](#) shows the dimension of the female plug.

Figure 2-2. USB-Blaster Dimension

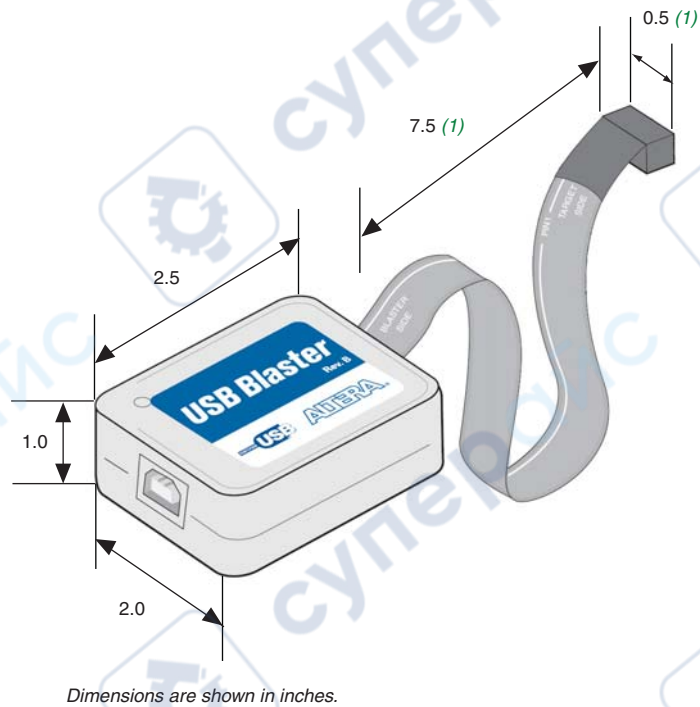

Note to Figure 2-2:

(1) For Rev. B and Rev. C.

Figure 2-3. USB-Blaster 10-Pin Female Plug Dimensions

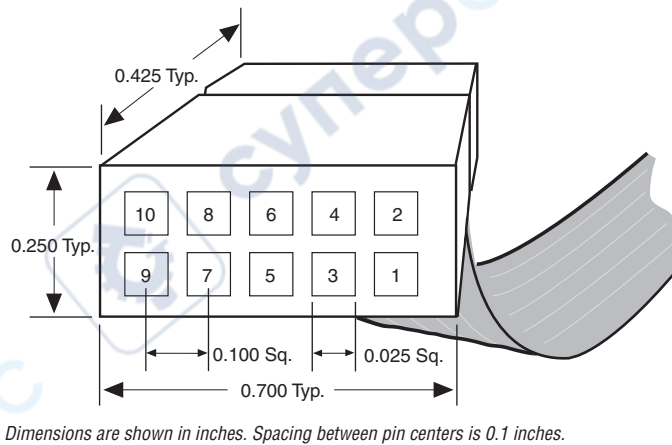

[Table 2-2](#) identifies the 10-pin female plug pin names and the corresponding programming mode.

Table 2-2. USB-Blaster Female Plug Signal Names & Programming Modes

Pin	AS Mode		PS Mode		JTAG Mode	
	Signal Name	Description	Signal Name	Description	Signal Name	Description
1	DCLK	Clock signal	DCLK	Clock signal	TCK	Clock signal
2	GND	Signal ground	GND	Signal ground	GND	Signal ground
3	CONF_DONE	Configuration done	CONF_DONE	Configuration done	TDO	Data from device
4	VCC (TRGT)	Target power supply	VCC (TRGT)	Target power supply	VCC (TRGT)	Target power supply
5	nCONFIG	Configuration control	nCONFIG	Configuration control	TMS	JTAG state machine control
6	nCE	Cyclone chip enable	—	No connect	—	No connect
7	DATAOUT	Active serial data out	nSTATUS	Configuration status	—	No connect
8	nCS	Serial configuration device chip select	—	No connect	—	No connect
9	ASDI	Active serial data in	DATA0	Data to device	TDI	Data to device
10	GND	Signal ground	GND	Signal ground	GND	Signal ground

 The circuit board must supply $V_{CC(TRGT)}$ and ground to the USB-Blaster cable for the I/O drivers.

Circuit Board Header Connection

The circuit board's 10-pin male header, which connects to the USB-Blaster cable's 10-pin female plug, has two rows of five pins. These pins are connected to the device's programming or configuration pins. [Figure 2-4](#) shows the dimensions of a typical 10-pin male header.

 Although a 10-pin surface mount header can be used for the JTAG, AS or PS download cable, Altera recommends using a through-hole connector because of the repeated insertion and removal force needed.

Figure 2-4. 10-Pin Male Header Dimensions

Operating Conditions

Table 2-3 through Table 2-5 summarize the maximum ratings, recommended operating conditions, and DC operating conditions for the USB-Blaster cable.

Table 2-3. USB-Blaster Cable Absolute Maximum Ratings

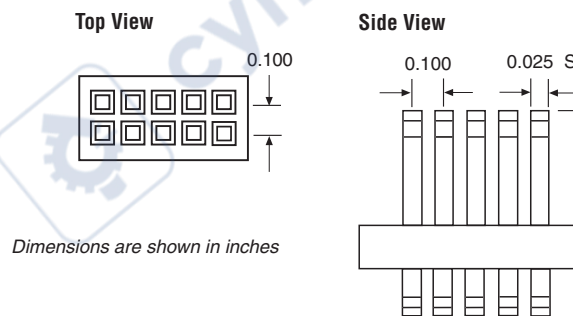
Symbol	Parameter	Conditions	Min	Max	Unit
$V_{CC(TRGT)}$	Target supply voltage	With respect to ground	-0.3	5.5	V
$V_{CC(USB)}$	USB supply voltage	With respect to ground	-0.5	6.0	V
I_I	Input current	TDO or dataout	-10.0	10.0	mA
I_O	Output current for Rev. A and Rev. B cable	TCK, TMS, TDI, nCS, nCE	-20.0	20.0	mA
	Output current for Rev. C cable		-50.0	50.0	mA

Table 2-4. USB-Blaster Cable Recommended Operating Conditions

Symbol	Parameter	Conditions	Min	Max	Unit
$V_{CC(TRGT)}$	Target supply voltage, 5.0-V operation	—	4.75	5.25	V
	Target supply voltage, 3.3-V operation	—	3.0	3.6	V
	Target supply voltage, 2.5-V operation	—	2.375	2.625	V
	Target supply voltage, 1.8-V operation	—	1.71	1.89	V
	Target supply voltage, 1.5-V operation (1)	—	1.43	1.57	V

Note to Table 2-4:

(1) This operating condition can be applicable to USB-Blaster Cable (Rev. A & B)

Table 2-5. USB-Blaster Cable (Rev. A & B) DC Operating Conditions

Symbol	Parameter	Conditions	Min	Max	Unit
V_{IH}	High-level input voltage	—	$V_{CC(TRGT)} - 0.2$		V
V_{IL}	Low-level input voltage	—		0.15	V

Table 2-5. USB-Blaster Cable (Rev. A & B) DC Operating Conditions

Symbol	Parameter	Conditions	Min	Max	Unit
V_{OH}	5.0-V high-level output voltage	$V_{CC(TRGT)} = 4.5\text{ V}, I_{OH} = 1\text{ mA}$	4.4		V
	3.3-V high-level output voltage	$V_{CC(TRGT)} = 3.0\text{ V}, I_{OH} = 1\text{ mA}$	2.9		V
	2.5-V high-level output voltage	$V_{CC(TRGT)} = 2.375\text{ V}, I_{OH} = 1\text{ mA}$	2.275		V
	1.8-V high-level output voltage	$V_{CC(TRGT)} = 1.71\text{ V}, I_{OH} = 1\text{ mA}$	1.61		V
	1.5-V high-level output voltage	$V_{CC(TRGT)} = 1.43\text{ V}, I_{OH} = 1\text{ mA}$	1.33		V
V_{OL}	5.0-V low-level output voltage	$V_{CC(TRGT)} = 5.5\text{ V}, I_{OL} = 1\text{ mA}$		0.125	V
	3.3-V low-level output voltage	$V_{CC(TRGT)} = 3.6\text{ V}, I_{OL} = 1\text{ mA}$		0.125	V
	2.5-V low-level output voltage	$V_{CC(TRGT)} = 2.625\text{ V}, I_{OL} = 1\text{ mA}$		0.125	V
	1.8-V low-level output voltage	$V_{CC(TRGT)} = 1.89\text{ V}, I_{OL} = 1\text{ mA}$		0.125	V
	1.5-V low-level output voltage	$V_{CC(TRGT)} = 1.57\text{ V}, I_{OL} = 1\text{ mA}$		0.125	V
$I_{CC(TRGT)}$	Operating current (No Load)	(Typical $I_{CC(TRGT)} = 16\text{ }\mu\text{A}$)		100	μA

Table 2-6. USB-Blaster Cable (Rev. C) DC Operating Conditions

Symbol	Parameter	Conditions	Min	Max	Unit
V_{IH}	High-level input voltage	$V_{CC(TRGT)} \geq 2.0\text{ V}$	2.0		V
		$V_{CC(TRGT)} < 2.0\text{ V}$	$V_{CC(TRGT)}$		V
V_{IL}	Low-level input voltage	$V_{CC(TRGT)} \geq 2.0\text{ V}$		0.8	V
		$V_{CC(TRGT)} < 2.0\text{ V}$		0	V
V_{OH}	5.0-V high-level output voltage	$V_{CC(TRGT)} = 4.5\text{ V}, I_{OH} = -10\text{ mA}$	3.8		V
	3.3-V high-level output voltage	$V_{CC(TRGT)} = 3.0\text{ V}, I_{OH} = -8\text{ mA}$	2.3		V
	2.5-V high-level output voltage	$V_{CC(TRGT)} = 2.375\text{ V}, I_{OH} = -6\text{ mA}$	1.8		V
	1.8-V high-level output voltage	$V_{CC(TRGT)} = 1.71\text{ V}, I_{OH} = -4\text{ mA}$	1.2		V

Table 2-6. USB-Blaster Cable (Rev. C) DC Operating Conditions

Symbol	Parameter	Conditions	Min	Max	Unit
V_{OL}	5.0-V low-level output voltage	$V_{CC(TRGT)} = 5.5 \text{ V}$, $I_{OL} = 10 \text{ mA}$		0.8	V
	3.3-V low-level output voltage	$V_{CC(TRGT)} = 3.6 \text{ V}$, $I_{OL} = 8 \text{ mA}$		0.7	V
	2.5-V low-level output voltage	$V_{CC(TRGT)} = 2.625 \text{ V}$, $I_{OL} = 6 \text{ mA}$		0.6	V
	1.8-V low-level output voltage	$V_{CC(TRGT)} = 1.89 \text{ V}$, $I_{OL} = 4 \text{ mA}$		0.5	V
$I_{CC(TRGT)}$	Operating current (No Load)	(Typical $I_{CC(TRGT)} = 16 \text{ uA}$)		100	μA

USB-Revision

Table 2-7 indicates the revision and description of the USB-Blaster.

Table 2-7. USB-Revision

Revision	Descriptions	RoHS Compliant
Rev. A (1)	10-pin female connector is connected to the USB-Blaster through a ribbon cable.	No
Rev. B	10-pin female connector is connected to the USB-Blaster through a flexible PCB cable.	No
Rev. C	Hardware upgrade to meet the RoHS lead-free requirement. 10-pin female connector is connected to the USB-Blaster through a flexible PCB cable.	Yes

Note to Table 2-7:

- (1) Revision B and Revision C cable has a "Rev. B" and "Rev. C" marking on the casing. However, you can identify the Revision A cable if the cable is using a ribbon cable and does not have the revision marking.

Statement of China-RoHS Compliance

Table 2-8 lists hazardous substances included with the USB-Blaster download cable (Rev. C).

Table 2-8. Table of Hazardous Substances' Name and Concentration (Note 1)

Part Name	Lead (Pb)	Cadmium (Cd)	Hexavalent Chromium (Cr6+)	Mercury (Hg)	Polybrominated biphenyls (PBB)	Polybrominated diphenyl Ethers (PBDE)
Electronic Components	0	0	0	0	0	0
Populated Circuit Board	0	0	0	0	0	0
Manufacturing Process	0	0	0	0	0	0
Packing	0	0	0	0	0	0

Note to Table 2-8:

- (1) 0 indicates that the concentration of the hazardous substance in all homogeneous materials in the parts is below the relevant threshold of the SJ/T11363-2006 standard.

References

For more information on configuration and in-system programmability (ISP), see the following sources:

- [AN 39: IEEE 1149.1 \(JTAG\) Boundary-Scan Testing in Altera Devices](#)
- [AN 95: In-System Programmability in MAX Devices](#)
- [Configuring Arria GX Devices](#) chapter in volume 2 of the *Arria GX Device Handbook*
- [Configuring Cyclone FPGAs](#) chapter in the *Cyclone Device Handbook*
- [Configuring Cyclone II Devices](#) chapter in the *Cyclone II Device Handbook*
- [Configuring Cyclone III Devices](#) chapter in volume 1 of the *Cyclone III Device Handbook*
- [Configuring Stratix and Stratix GX Devices](#) chapter in the *Stratix Device Handbook*
- [Configuring Stratix II and Stratix II GX Devices](#) chapter in volume 2 of the *Stratix II Device Handbook*
- [Configuring Stratix III Devices](#) chapter in volume 1 of the *Stratix III Device Handbook*
- [In-System Programmability Guidelines for MAX II Devices](#) chapter in the *MAX II Device Handbook*
- [Programming & Configuration](#) chapter in the *Introduction to the Quartus II Software manual*
- [Quartus II Programmer](#) chapter in volume 3 of the *Quartus II Handbook*
- [Serial Configuration Devices \(EPCS1, EPCS4, EPCS16, EPCS64, and EPCS128\) Data Sheet](#) chapter in the *Configuration Handbook*
- Programming module of the Quartus® II online tutorial

- Refer to the following glossary definitions in the Quartus II Help:
 - “USB-Blaster Cable” (general description)
 - “Configuration scheme” (general description)
 - “Programming files” (general description)
- Refer to the following procedures in the Quartus II Help:
 - Programming a Single Device or Multiple Devices in JTAG or Passive Serial Mode
 - Programming a Single Device in Active Serial Programming Mode
- Refer to the following introduction and overview topics in the Quartus II Help:
 - Programmer Introduction
 - Overview: Working with Chain Description Files
 - Overview: Converting Programming Files

Revision History

The following table shows the revision history for this user guide.

Date	Version	Changes Made
April 2009	2.5	<ul style="list-style-type: none"> ■ Updated “Supported Devices” section ■ Updated “Software Requirements” ■ Deleted handnote in “Installing the USB-Blaster Driver on Windows Vista Systems” ■ Updated Table 2–1 ■ Added a handnote in “Circuit Board Header Connection” ■ Updated Table 2–5
April 2008	2.4	<ul style="list-style-type: none"> ■ Added “Statement of China-RoHS Compliance” ■ Added Table 2–8 ■ Added “Installing the USB-Blaster Driver on Windows Vista Systems”
May 2007	2.3	<ul style="list-style-type: none"> ■ Updated “Introduction” ■ Added warning note about USB-Blaster cable in “Hardware Setup” section ■ Added information on Linux setup in “Installing the USB-Blaster Driver on Linux” section ■ Added feetpara note on driver information just before the “Setting Up the USB-Blaster Hardware in the Quartus II Software” section ■ Updated USB-Blaster installation procedure for QII 6.1 (32-bit or 64-bit) in “Installing the USB-Blaster Driver on Windows 2000 and Windows XP Systems” section
March 2007	2.2	Update to “Installing the USB-Blaster Driver on Windows 2000 and Windows XP Systems” section
July 2006	2.1	Minor update to Chapter 2, USB-Blaster Specifications
June 2006	2.0	Added “Revision History” section, updated Figure 2–1, Table 2–1, and Table 2–7. Added Table 2–6
December 2004		Update to conditions in Table 2–2
November 2004	1.1	Re-release
July 2004	1.0	First publication

How to Contact Altera

For the most up-to-date information about Altera® products, see the following table.

Contact <i>(Note 1)</i>	Contact Method	Address
Technical support	Website	www.altera.com/support
Technical training	Website	www.altera.com/training
	Email	custrain@altera.com
Altera literature services	Email	literature@altera.com
Non-technical support (General)	Email	nacomp@altera.com
(Software Licensing)	Email	authorization@altera.com





Note:

(1) You can also contact your local Altera sales office or sales representative.

Typographic Conventions

The following table shows the typographic conventions that this document uses.

Visual Cue	Meaning
Bold Type with Initial Capital Letters	Command names, dialog box titles, checkbox options, and dialog box options are shown in bold, initial capital letters. Example: Save As dialog box.
bold type	External timing parameters, directory names, project names, disk drive names, file names, file name extensions, and software utility names are shown in bold type. Examples: f_{MAX} , qdesigns directory, d: drive, chiptrip.gdf file.
<i>Italic Type with Initial Capital Letters</i>	Document titles are shown in italic type with initial capital letters. Example: <i>AN 75: High-Speed Board Design</i> .
<i>Italic type</i>	Internal timing parameters and variables are shown in italic type. Examples: <i>t_{PIA}</i> , <i>n + 1</i> . Variable names are enclosed in angle brackets (<>) and shown in italic type. Example: <i><file name></i> , <i><project name>.pdf</i> .
Initial Capital Letters	Keyboard keys and menu names are shown with initial capital letters. Examples: Delete key, the Options menu.
"Subheading Title"	References to sections within a document and titles of on-line help topics are shown in quotation marks. Example: "Typographic Conventions."
Courier type	Signal and port names are shown in lowercase Courier type. Examples: <code>data1</code> , <code>tdi</code> , <code>input</code> . Active-low signals are denoted by suffix <code>n</code> , e.g., <code>resetn</code> . Anything that must be typed exactly as it appears is shown in Courier type. For example: <code>c:\qdesigns\tutorial\chiptrip.gdf</code> . Also, sections of an actual file, such as a Report File, references to parts of files (e.g., the AHDL keyword <code>SUBDESIGN</code>), as well as logic function names (e.g., <code>TRI</code>) are shown in Courier.
1., 2., 3., and a., b., c., etc.	Numbered steps are used in a list of items when the sequence of the items is important, such as the steps listed in a procedure.
■ ■	Bullets are used in a list of items when the sequence of the items is not important.
✓	The checkmark indicates a procedure that consists of one step only.
☞	The hand points to information that requires special attention.

Visual Cue	Meaning
	A caution calls attention to a condition or possible situation that can damage or destroy the product or the user's work.
	A warning calls attention to a condition or possible situation that can cause injury to the user.
	The angled arrow indicates you should press the Enter key.
	The feet direct you to more information on a particular topic.