

Rek[®] Meiruike Instruction Manual

RK9910/RK9920
Series of AC/DC Withstanding
Voltage & Resistance Tester

SHENZHEN MEIRUIKE ELECTRONIC TECHNOLOGY CO.,LTD

Version history:

Due to the possible errors or omissions in the manual, improvement and perfection of instrument functions, updating of technology and upgrading of software, the manual will be adjusted and revised accordingly and continuously improved for the convenience of use.

Please pay attention to the software version and manual version.

Statement: the company may improve and improve the performance, function, software, structure, appearance, accessories, packaging and instruction manual of the product. Any modification is subject to no further notice! If in doubt, please contact us.

目录

Chapter 1 Installation and Use	1
1.1 Precautions for Use	1
1.2 Points for Attention when Moving	3
1.3 Connect AC power cord	4
1.4 Grounding	4
1.5 Operational Inspection	6
1.6 Other characteristics of the instrument	7
Chapter 2 Operating Specifications and Measures	8
2.1 Prohibited Operations	8
2.2 Emergency Treatment	10
2.3 Preventive Measures in Testing	10
△ Warning: The jacket on the alligator clip of the test line provided by the instrument is not sufficiently insulated from the test high voltage. Do not touch these parts during the test.	11
2.4 High Voltage Test Warning	12
2.5 Handling of Dangerous States of Faulty Instruments	14
2.6 Conditions for Guaranteeing Long-term Fail-free Use	15
2.7 Daily Inspection	16
Chapter 3 Overview of Instrument Panel	16
3.1 Front Panel Description	17
3.1.2 START key and STOP key	17
3.1.3 Trademarks and Models	17
3.1.4 Numeric Keypad	18
3.1.5 Indicator area	18
3.1.6 FUNCTION	18
3.1.7 HV	19
3.1.8 High Voltage End of Output Voltage	19
3.1.9 Test LOW End, Test Current Return End (LOW, RET)	19
3.1.10 Move key	19
3.1.11 Rotary encoder potentiometer	19
3.1.12 Shortcut function keys	20
3.1.13 480*272TFT	20
3.1.14 USB interface	20
3.1.15 LOCK key	20
3.2 RK910/20 Series Rear Panel Description	20
1. Power amplifier fan cooling port	21
2. Test Low End, Test Current Return End (Option)	21
3. High Voltage Output (Option)	21
4. Power socket	21
5. Protective earth terminal	21
6. Nameplate	22
7. RS232 serial interface	22
8. USB Device	22
9. Handler Interface	22

10. Single interface.....	23
11.RS485 serial interface.....	23
12.110/220V Power Switch.....	24
3.3 Medical programmable pressure meter RK9910AY/BY RK9920AY/BY rear panel description	24
3.4 Overview of Instrument Performance.....	26
Chapter 4 Basic Operation	33
4.1 Overview of Instrument Interface Structure.....	33
4.2 Panel Function Interface and Parameter Description	35
4.2.1 SETUP measurement setup.The interface schematic is as follows:.....	37
4.2.2 TEST test interface.The interface schematic is as follows: (take AC as an example).....	39
4.2.3 System interface. The interface diagram is as follows:	41
4.2.4 FILE File Storage Interface	44
Press (FILE key) to enter the file management interface as follows:	44
.....	44
4.3 Test Project Interface and Parameter Description	44
4.3.1 AC withstand voltage test parameter setting.....	45
The setting interface is as follows:	45
4.3.2 DC DC withstand voltage test parameter setting.The setting interface is as follows:.....	46
4.3.3 IR Insulation Resistance Test Parameter Setting.	47
4.4 Test Function Principle and Instructions for Use.....	49
4.4.1 Start Test	50
4.4.2 Test Delay	50
4.4.3 Voltage rise.....	50
4.4.4 DC boost determination.....	51
4.4.5 high voltage test.....	51
4.4.6 Test Voltage Drop	52
4.4.7 Ground wire current detection function.....	52
4.4.8 Current Overrun and arc detection function	53
4.4.9 Unqualified Judgment	56
4.4.10 Processing of Test Results	57
4.4.11 STOP (Stop Measurement).....	58
4.4.12 OFFSET (base cleared).....	58
4.5 HANDLER and SIGNAL Interface Circuit Structure and Use.....	59
4.5.1 Control Interface Principle	59
4.5.2 Use of Control Interface	61
4.6 Other Interfaces and Functions of Instruments	63
Chapter 5 Description of Serial Port Instruction Set	63
Brief description of instruction format:	63
5.1 S C PI instruction set.....	64
5.2 DISPLAY subsystem command set.....	65
5.3 FUNCTION Subsystem Command Set	66
5.3.1 FUNCTION subsystem command set is mainly used to set test parameters of instrument test function.	66

5.3.2 PROG Function Command Set.....	66
5.3.3 AC Setup function command set.....	67
5.3.4 DC Setup function command set.....	73
5.3.5 IR Setup function command set.....	76
5.4 SYSTEM Subsystem Command Set.....	78
5.5 MMEM Subsystem Command Set.....	84
5.6 FETCH Subsystem Command Set.....	84
5.7 Other Control Command Sets.....	86
Chapter 6 Technical Parameters.....	86
6.1. Specific Parameters.....	86
6.2. General technical indicators.....	90
7. Instrument System Upgrade Steps:.....	90
8 .Appendix: Parameter Table.....	91
9. Overview and Parameters of RK99 Series Programmed Medical withstand voltage tester	93
10 、 Attached accessories.....	98
Chapter 7 Description of multi-channel voltage-resistant insulation resistance tester.....	98
7.1 Description of the multi-channel module.....	99
7.2 The SCAN Multichannel Setup Step.....	99
7.3 Parameter table of Rk9920 series multi-channel voltage-resistant insulation resistance tester.....	104
7.4 Channel test diagram.....	108
7.5 Multi-channel SCPI serial port communication instruction.....	108
7.6 Backing list.....	112
Chapter 8: RK9914A Series Technical Parameters.....	112
Chapter 9: RK9974 Series Technical Parameters.....	111

Chapter 1 Installation and Use

This chapter describes some checks that must be carried out when you receive the instrument and the conditions that must be understood and met before installing and using the instrument.

This instrument conforms to the GB4793.1-2007/IEC61010-1:2001 standard.

1.1 Precautions for Use

The following rules must be observed when using the instrument:

- Do not use this instrument in flammable air

In order to prevent burning or explosion, do not be near alcohol, diluent and other combustible materials, do not use the instrument in the air with high concentration of these gases.

- Avoid exposure to high temperatures and direct sunlight

Do not place the instrument in a place with heat or drastic temperature changes.

Operating temperature range of the instrument: 5°C to +35°C

Storage temperature range of the instrument; -20°C to +60°C

- Avoid humid environment

Do not place the instrument in boiler, humidifier or high humidity environment with water.

Humidity range of the instrument: 20% to 80%RH (dew condensation is

not allowed)

Humidity range of instrument storage; Less than 90%RH (dew condensation is not allowed)

Condensation may cause the circuit to malfunction. The instrument cannot be used until the environment is completely dry.

■ Do not place the instrument in an environment with corrosive gases.

Do not use the instrument in an environment with corrosive gases such as sulfuric acid, fog or the like. This may corrode wires, connectors and form hidden dangers or connection defects. It can lead to failures, and even fires.

■ Do not use the instrument in dusty environment

Soil and dust can cause short circuit of electronic devices or fire.

■ Do not use the instrument in poorly ventilated places

The instrument has a forced air-cooled heat dissipation system. Sufficient space should be provided for the side and rear tuyeres to ensure air circulation.

■ Do not use the instrument on an inclined surface or in a shaking place

If the instrument is placed on an uneven surface or a shaking place, the instrument may slide down and damage the instrument.

■ Do not use the instrument in places with strong magnetic or electric

field

When the instrument is used in places with strong magnetic field or electric field, electromagnetic pulse will cause instrument failure and fire.

■ Do not use this instrument near sensitive test equipment and receiving equipment

If these devices are used in the vicinity of this instrument, the noise generated by failure and breakdown of the tested parts may affect these devices. When the test voltage exceeds 3KV, the electric field between the test lines will ionize the air and generate corona, which will generate a large amount of RF (radio frequency) bandwidth interference between the test lines.

In order to reduce this influence and ensure the distance between test lines is far enough.

In addition, keep the test line away from conductive surfaces (especially sharp metal ends).

1.2 Points for Attention when Moving

When moving or transporting the instrument, pay attention to the following precautions:

■ Turn off the power switch before moving

Moving with the power switch on will cause electric shock and damage.

- Disconnect all connecting wires before moving.

Moving the instrument without disconnecting the cable may cause damage to the connecting cable or drop the instrument during moving.

1.3 Connect AC power cord

The power cord is supplied with the instrument by our company. Do not use AC power cord that is not standard on this instrument.

Connection sequence

1. Make sure the power supply is within the line power supply range of the instrument.
2. Determine the nominal value of the instrument fuse, and the fuse box is installed in the correct position (power file).
3. Make sure the power switch of the instrument is turned off.
4. Connect the AC power cord to the AC LINE end of the rear panel.
5. Please use the attached AC power cord or the AC power cord selected by qualified professionals.
6. Insert the AC power socket.

1.4 Grounding

△Warning: Make sure the instrument is connected to electrical ground (safely, earth).

If the output to the ground connected to the peripheral equipment or

the nearby commercial wire is not directly connected to the ground, the instrument shell may have a very high voltage and become very dangerous.

This instrument is Class II equipment (except for basic insulation, the equipment is protected from electric shock).

However, it is still possible to get electric shock without proper grounding.

In order to ensure safety, please make sure the instrument is grounded.

Select one of the following two available methods to de-ground:

1. The power cord is connected to a single-phase three-wire power outlet. (Please ensure that the socket grounding wire is available by connecting the earth)
2. Connect the protective terminal of the rear panel to the earth via the grounding bar (provided in the production line and reliably connected to the earth copper wire or bar) to the earth. Let specialized engineers select, make and install the Ground connection line. To ensure that the grounding connection is correct and reliable.

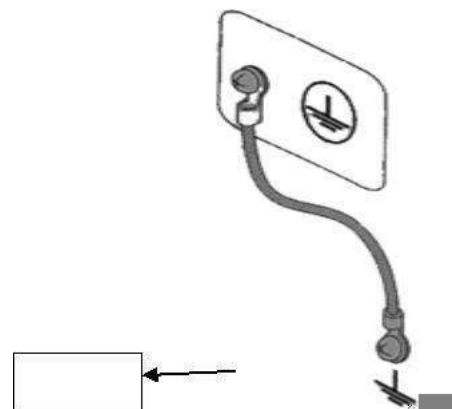

1.5 Operational Inspection

△ Warning: When using the instrument normally, as far as possible make function interlock (interlock) to ensure the safety of use.

When the working space is relatively cramped: make a box-like structure for the tested piece;

In the case of testing large-scale test pieces with complicated structures: protective structures such as fences and the like are used around the test area to prevent electric shock.

When the electric shock protection structure is opened, the signal circuit is disconnected to ensure the safety of the workplace.

When the power switch is turned on, the instrument lights up all the lights on the front panel and starts self-checking, making sure all the lights are on to ensure safety.

It is particularly dangerous to carry out the test when the DANGER lamp is damaged.

△ Caution: After switching off the power switch, it will take several seconds to turn on the machine again. Repeated on/off power supply without sufficient time interval has damaged.

Check sequence

1. Make sure that the allowable range of power supply voltage is

consistent with the input voltage range set by the fuse box.

2. Make sure that the AC power cord is connected to the AC LINE end of the rear panel.
3. Insert the power plug into the AC power outlet.
4. Turn on the power switch to ensure that the indicator light on the front panel is all on and the panel displays the start-up screen.
5. The following screen displays the AC withstand voltage test (AC) parameter interface of the SETUP interface.
6. Turn off the power switch.

Note the boot screen (example):



The startup screen model, version, and date display are subject to the actual model display.

1.6 Other characteristics of the instrument

(1) Power consumption: power consumption < 300VA (RK 9920/A/B)
< 200VA (RK 9910/A/B).

(2) Overall dimensions (W*H*D) : 350mm*110mm*430mm ;

(3) Weight: about 15kg(RK 9920/A/B); About 14kg (RK 9910/A/B) .

Input voltage	Frequency Range	Fuse (slow melting)	model	rated power
---------------	-----------------	---------------------	-------	-------------

110V	47-63Hz	5A	RK9920	400VA
			RK9910	300VA
3A		RK9920	400VA	
		RK9910	300VA	

Chapter 2 Operating Specifications and Measures

This chapter describes the specifications and measures to be followed during the use of this instrument. When using this instrument, special attention should be paid to ensure safety.

△ Warning: This instrument produces a test high voltage of 5kV that can cause personal injury or even death. When operating the instrument, you must be very careful and observe it.

2.1 Prohibited Operations

■ Do not switch power supply continuously

After the power switch is cut off, make sure there is an interval of one minute or more before the power switch is turned on again. Ensure the normal power failure of the circuit before starting.

If the power supply of the instrument is repeatedly turned on/off frequently, the control circuit of the instrument may be abnormal due to incomplete power failure. At this time, the protection facilities may the protection function cannot be completely performed.

Except in special or urgent circumstances. Do not turn off the power

switch when the instrument is generating test voltage.

■ Do not short circuit the output to ground

If the high voltage test line of the instrument is connected to AC LINE (AC power line); Or other nearby devices (such as transmission devices) conductor of the earth. When the grounding end of the instrument is unreliable, the low end of the high voltage the shell of the instrument) will be filled with danger after the high voltage end is grounded.

Make sure that the protective earth terminal of the instrument is connected to the earth wire. In this way, even if the HIGH VOLTAGE terminal and the ground terminal are short-circuited, the instrument housing will not be charged with high voltage and there will be no danger.

When grounding the protection ground terminal, ensure it is correct and reliable. See "1.5 Grounding".

△Note: The term "AC LINE" refers to the power cord used by the instrument. It is the power source of commercial alternating current or power generation and the power source of instruments connected wires.

■ Do not connect external voltage to test terminal

Do not connect any external voltage to the output of the instrument. In non-discharge state, the instrument does not have external discharge function, output terminal and external voltage connecting may damage the instrument.

2.2 Emergency Treatment

In case of emergency (e.g. electric shock and burning of the tested part) and the instrument does not disconnect the high-voltage output, the following operations shall be carried out. You can do to (a) or (b), but both operations must be done.

(a) Turn off the power switch of the instrument;

(b) Unplug the power cord of the instrument from the power cord plug.

2.3 Preventive Measures in Testing

■ Wear insulating gloves

Wear insulating gloves when using the instrument to protect yourself from touching high-voltage electricity. Even if you wear high-voltage gloves, you are not allowed to use your hands in high voltage test to contact with a live conductor.

■ Discontinue (suspend) test preventive measures

When touching the test conductor or changing the test connection, first press the STOP switch once to ensure that the instrument exits the test preparation state.

If you need to rest for a period of time or will leave the testing place, please turn off the power switch to prevent the safety caused by touching the starting switch by mistake.

■ Electrified articles in high voltage test

During the test, the high-voltage output terminal, the high voltage test line, the high-voltage probe, the tested piece and the conductor exposed around them all carry dangerous high-voltage electricity.

Do not approach or touch these conductors at will even if there are reliable insulation measures during testing.

△ Warning: The jacket on the alligator clip of the test line provided by the instrument is not sufficiently insulated from the test high voltage. Do not touch these parts during the test.

■ Precautions after Switching off High Voltage Output

If you have to touch the tested piece, test line, probe or output end and the surrounding area due to re-connection or other reasons, ensure the following two notices:

(a) Verify that the working state displayed by the instrument is not the test state.

(b) HV lamp goes out.

■ Remote Control Warning

Because the start and stop of high voltage is controlled remotely, the operator cannot know the actual working state of the instrument

through the interface and is performing remote control.

Use special care when operating the instrument in mode. Please pay special attention to check the reliable connection of remote control.

(c) The "STOP" button must be connected reliably. Press the "STOP" button before replacing the tested piece.

(d) When working in a crowded working environment, the remote control switch must have an "INTLOCK" interlock switch and a high voltage indicator. Disconnect the "INTLOCK" interlock switch before replacing the tested piece.

2.4 High Voltage Test Warning

△ Warning: In high voltage test, the test line, test probe, and the tested piece are all charged with high voltage. The instrument has a discharge circuit and sometimes needs to be discharged after the output is cut off. Danger of electric shock during discharge. In order to avoid electric shock, ensure that the tested piece, test line, probe and output with high voltage do not touch anything other than the test element. If you may come into contact with these, make sure the DANGER lamp goes out and remove the hidden danger.

Once the test is finished, the discharge circuit of the instrument starts to discharge forcibly. Do not disassemble the tested part during the test and before the discharge is completed.

Under normal circumstances, it can be ensured that the voltage of the test loop will be within the range of safe voltage at the end of discharge. When the capacitance of the tested piece is too large or the special structure of the tested piece will cause incomplete discharge, technicians must change the testing method to ensure complete discharge.

■ Discharge time:

Calculation formula of discharge time: $t = -\ln(30/U) \times R \times C$

T: discharge time

30: Discharge remaining safe voltage 30V

U: test set voltage

R: the discharge impedance of the tested piece, and the instrument discharge impedance is about 10k.

C: capacitance of the tested part

In general, only DC high voltage test needs to be discharged, and the length of discharge time depends on the nature of the tested piece.

During the test, if the test ends normally, the voltage will drop to zero according to the voltage drop time. If the test fails, the discharge of the tested element is realized through the secondary side of the transformer (about 10k resistance), and the 1uF capacitor with 6000V high voltage is discharged to 30V for about 0.05S. The fixed discharge time of the instrument is 0.2S, which can ensure that the device is completely

discharged.

2.5 Handling of Dangerous States of Faulty Instruments

Typical possible dangerous states of the instrument, the most dangerous of which is the occurrence of "high voltage at output and out of control of the instrument".When this happens,

1. Turn off the power switch immediately and unplug the AC power cord from the AC power outlet.
2. Please stay away from this instrument immediately and ask relevant technicians to check the test circuit to make sure there is no danger.Or let the instrument stand for more than one hour to confirm that there is no output voltage at the test end.
3. Remove the relevant connecting wires and send the instrument back to us for maintenance.

△ Warning: Stay away from this instrument immediately after turning off the power supply and prevent other personnel from approaching.

Never disassemble the test circuit immediately.

Contact our distributor or agent immediately.High voltage may remain inside the instrument, and it is very dangerous for non-professional personnel to try to overhaul the instrument.

2.6 Conditions for Guaranteeing Long-term Fail-free Use

Due to the volume, weight and actual usage of the instrument, the heat dissipation design of the voltage generation module of the instrument is relatively small. Therefore, the instrument is recommended to be used in the following range.

Necessary Conditions for Voltage Withstand Test

Ambient temperature	Output power	Pause time	Output time limit
AC $T \leq 40^{\circ}\text{C}$	> 12mA (RK9920 / A/B) > 6mA (RK9910 / A/B)	At least as long as the output time	Up to 1 minute
	<8mA (RK9920 / A / B) <4mA (RK9910 / A / B)	No requirement	Can output continuously
DC	> 6mA (RK9920 / A) > 3mA (RK9910 / A)	At least as long as the output time	Up to 1 minute
	<4mA (RK9920 / A) <2mA (RK9910 / A)	At least one charge waiting time Sample length (WAIT TIME)	Can output continuously

Note: Output time= (Voltage rise time + test time + voltage drop time)

The fan works continuously for 30 minutes, and the use of the instrument must be suspended, otherwise the power amplifier output module may burn down due to overheating.

2.7 Daily Inspection

In order to avoid accidents, at least the following points should be guaranteed before use:

1. The input power of the instrument conforms to the specifications, and the power supply of the instrument is configured correctly.
2. The instrument is reliably connected with the earth.
3. The material of the test line is in good condition, free from fracture, crack and breakage.
4. The instrument is not connected to the test line, and the test can be started under the default condition, and the test can be successfully completed.
5. When the test line is connected to start the test, the low-voltage end of the test line contacts the high-voltage end of the test line, and the instrument can generate a FAIL signal.

Chapter 3 Overview of Instrument Panel

This chapter describes the basic operating characteristics of RK9910/20 series instruments. Before using the series of instruments, please read this chapter in detail so that you can learn the operation of the series very quickly.

3.1 Front Panel Description

Figure 3-1 briefly illustrates the series of front panels.



图 3-1 前面板说明

3.1.1 POWER switch (POWER)

Power switch. Before starting the machine for the first time, the operator should pay attention to check whether the power type of the instrument and the connection of the test line are normal.

3.1.2 START key and STOP key

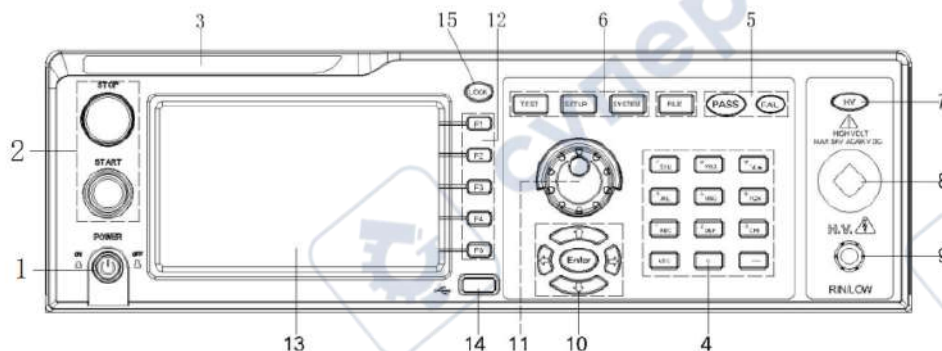
START key (green circle): used to start the test. once the test starts, the HV indicator will be on.

STOP key (red circle): stop key to stop the test; Can also be used to cancel PASS, FAIL and other prompt status.

3.1.3 Trademarks and Models

Trademarks and models of instruments

3.1.4 Numeric Keypad

Used for numeric value input

3.1.5 Indicator area

- FAIL

During the test, the set test data is exceeded, the instrument judges that the test is unqualified, and the FAIL judgment light is on.

- PASS

After the test, no test data beyond the initial setting is found. The instrument judges that the test is qualified and PASS judges that the light is on.

When the test timing function is turned off (TIME OFF), the test can only be ended with 'STOP' without PASS judgment.

3.1.6 FUNCTION

Select test mode setting, system setting and document operation interface.

- TEST

Press this key to turn on the light, and the instrument will enter the ready test state.

- SETUP

Press this key to turn on the light, and the instrument will enter the

parameter setting interface.

- SYSTEM

This key is lit to display the SYSTEM setting interface (SYSTEM)

- FILE

This key is lit to display the FILE operation interface (FILE)

3.1.7 HV

DANGER !! As long as the test is in progress, the light will come on, indicating that the test is in progress.

3.1.8 High Voltage End of Output Voltage

High voltage output of high voltage test interface.

3.1.9 Test LOW End, Test Current Return End (LOW, RET)

The output terminal of the test voltage and the current sampling terminal.

3.1.10 Move key

Used for cursor movement on the screen and selection of parameter items.

3.1.11 Rotary encoder potentiometer

Used to adjust and confirm parameters.

3.1.12 Shortcut function keys

F1-F5 correspond to the functional operation area on the right side of the LCD to realize quick operation.

3.1.13 480*272TFT

dot matrix liquid crystal display, display setting interface, measurement interface, etc.

3.1.14 USB interface

USB HOST can be realized and peripheral storage can be connected.

3.1.15 LOCK key

Press this key to lock all the keys on the operation panel except START and STOP keys. Prevent misoperation.

3.2 RK910/20 Series Rear Panel Description

Figure 3-2 briefly illustrates the RK9910/20 series rear panel



图 3-2 后面板说明

1. Power amplifier fan cooling port

Power amplifier circuit cooling port, pay attention to keep the air circulation space.

2. Test Low End, Test Current Return End (Option)

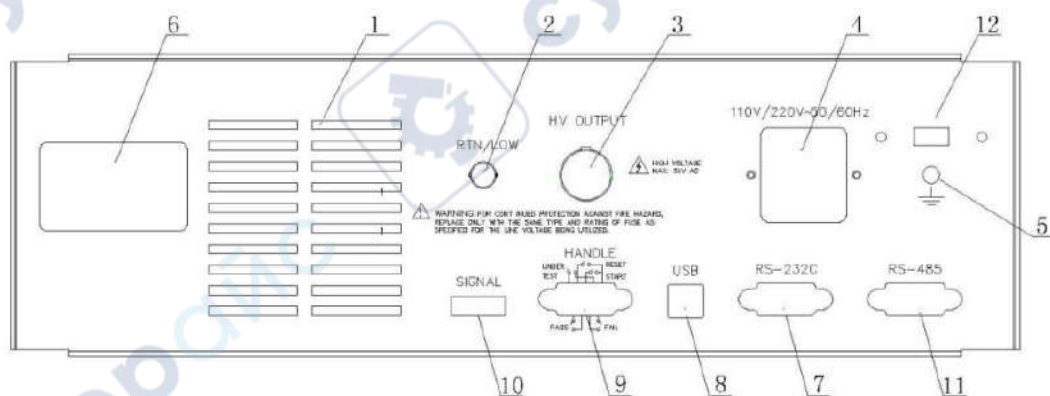
The test low end of the spare high voltage test interface can be modified when the customer needs it.

3. High Voltage Output (Option)

The high voltage output of the spare high voltage test interface can be modified when required by the customer.

4. Power socket

For AC power input, please use the voltage within the specified input voltage range of the instrument, and please use the power cord provided by the instrument.

Built-in power fuse, select fuse corresponding to input power.

5. Protective earth terminal

When the three-pin power socket plugged into the power supply of the instrument cannot ensure reliable connection to the earth, it must be connected to a reliable grounding bar from now on.

Note: This instrument should not be used without connecting to the earth, otherwise the shell of the instrument may carry high voltage and be in danger of electric shock.

6. Nameplate

Record of instrument factory number.

7.RS232 serial interface

Serial communication interface to realize communication with computer.

8. USB Device

U disk mapping of the instrument on the computer side can be realized, and internal storage files can be directly read.

9.Handler Interface

24V power supply, INTLOCK function.

TEST: Synchronous control signal output by the machine when the instrument starts high voltage output.

START: Enter the START signal of the machine to start the high voltage output, which is equivalent to the start signal of the front panel.

RESET: Enter the reset signal of this machine to STOP high voltage output, which is equivalent to the STOP signal of the front panel.

PASS: The qualified signal output by this machine is equivalent to PASS indication on the front panel.

FAIL: The unqualified signal output by this machine is equivalent to the FAIL indication of the front panel.

10. Single interface

This interface is online protection and internal 24V power output interface.

INT LOCK :

(port: (5)INT LOCK+(6)COM) short circuit valid.

The online locking signal of this machine is shorted by short circuit jumper by default. This machine is not allowed to start tests when disconnected.

DC 24V power supply:

(Ports: (1,2) 24 V+(3,4) GND).

The output voltage is 18.5VAC rectified output, with no voltage stabilizing function. It is used for control power supply requirements such as indicator lights. It is recommended that the total current is less than 500mA when the user uses it.

11.RS485 serial interface

Serial communication interface to realize communication with

computer.

12.110/220V Power Switch

The conversion of the input power supply voltage 110V 220V is realized.

3.3 Medical programmable pressure meter RK9910AY/BY RK9920AY/BY rear panel description

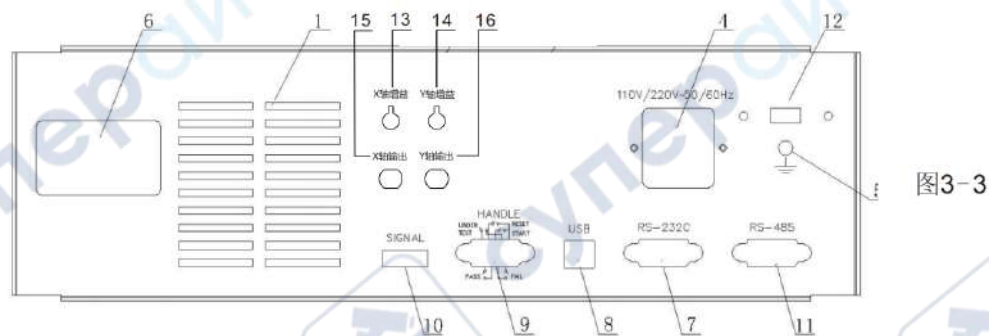

Fig. 3-3 briefly illustrates the rear panel of the medical program-controlled pressure meter.

In addition to the functions of ordinary program-controlled pressure meter 1, 4, 5, 6, 7, 8, 9, 10, 11 and 12, the following functions are added to the rear panel:

- 13. X-axis gain adjustment potentiometer
- 14. Y-axis Gain Adjustment Potentiometer
- 15. x-axis output interface
- 16. Y-axis Gain Adjustment Potentiometer

Introduction to Arc (Flash over) Detection

(1) Connect the pressure meter X-axis output socket (BNC socket) with the oscilloscope X-axis input socket with BNC-BNC connection line.

(2) Connect the Y-axis output socket of the pressure meter (BNC socket) with the Y-axis input socket of the oscilloscope by using BNC-BNC connection line.

(3) Set the X axis and Y axis of the oscilloscope to 0.2V/grid respectively.

(4) Connect the voltage withstand meter and oscilloscope power supply, and adjust the oscilloscope.

(5) Adjust the X-axis gain adjustment potentiometer and Y-axis gain adjustment potentiometer of the pressure gauge and the X-axis and Y-axis of the oscilloscope respectively, so that the oscilloscope displays a smooth and stable ring (or oval ring) namely Lissajous figure.

(6) Connect and test the tested object according to Articles 1, 2, 3 and 4.

(7) during the test, Li shayu's figure (circle) remains smooth and stable, so the tested electrical equipment has no "flashover" and "arcing" phenomena (as shown in fig. 1).

(8) During the test, if burr or jitter is generated at the edge (ring) of Li shayu's graph, the tested electrical equipment will have "flashover" and "arcing" phenomena (as shown in figs. 2 and 3).

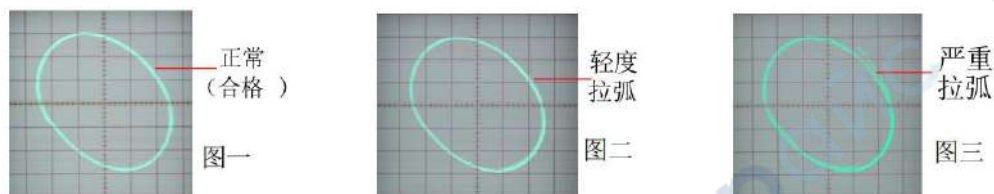

3.4 Overview of Instrument Performance

RK 9920 can provide 5kVAC/20mA withstand voltage, 6kVDC/10mA withstand voltage and insulation resistance test.

RK 9920A can provide 5kVAC/20mA withstand voltage and 6kVDC/10mA withstand voltage tests.

RK 9920B can provide 5kVAC/20mA withstand voltage test.

RK 9910 can provide 5kVAC/10mA withstand voltage, 6kVDC/5mA withstand voltage and insulation resistance test.

RK 9910A can provide 5kVAC/10mA withstand voltage and 6kVDC/5mA withstand voltage tests.

RK 9910B can provide 5kVAC/10mA withstand voltage test.

The principle and structure of the instrument:

Since the MCU processor generates signals, the sine wave generated by the signal processing circuit is amplified by the power amplifier, and the high voltage is produced by the 40 ~ 600 Hz high voltage transformer. DA reference signal ensures controllable voltage amplitude. The controllable sine wave can be set at 50 or 60Hz at AC output. In order to solve the problem of power ripple in DC and insulation resistance tests, a

600Hz AC power supply is rectified to form a DC voltage as the power supply. The output voltage adopts closed-loop control to ensure small load adjustment rate.

RK 9910/20 series can be used for AC voltage resistance test, DC voltage resistance test and insulation resistance test.

RK9 910/20 series are equipped with HANDLER, RS-232C, RS485 and USB, which make the instrument adapt to many different automatic test systems that require high safety and reliability.

Features:

- Three test functions-AC withstand voltage test, DC withstand voltage test, insulation resistance test.

RK9910 and RK9920 provide AC and DC withstand voltage test and insulation resistance test.

Rk9910A and RK9920A provide AC and DC withstand voltage tests.

RK9910B and RK9920B provide AC withstand voltage test.

- Two kinds of test power selection RK9 920 series high-voltage modules are Class AB power amplifier circuit and a 100VA high-voltage transformer to realize AC and 5kV/20mA output. DC, 6kV/10mA output. The distortion of the waveform is less than 3%.

RK9 910 series of high-voltage modules are Class AB power amplification circuits and a 50VA high-voltage transformer, which realize AC and 5kV/10mA output. And outputs of DC and 6kV/5mA. The distortion

of the waveform is less than 3%.

If the customer outputs continuous current, in order to ensure the reliability of the instrument, the maximum output time is 60 seconds when working above 60% of the rated output current. Please pay attention to limit continuous working time within 60% ~ 40% of rated output current. Below 40% rated output current to ensure continuous work.



图 3-3交流电压负载调整率

■ DC withstand voltage test 6kV/10mA (RK9 920/A) 6KV/5mA (RK9 910/A)

RK9 910/20 series can provide DC withstand voltage test with wide voltage range (maximum output DC 6KV). Automatic voltage adjustment of 600Hz frequency hardware, voltage load adjustment rate $\leq 1\% + 10V$.

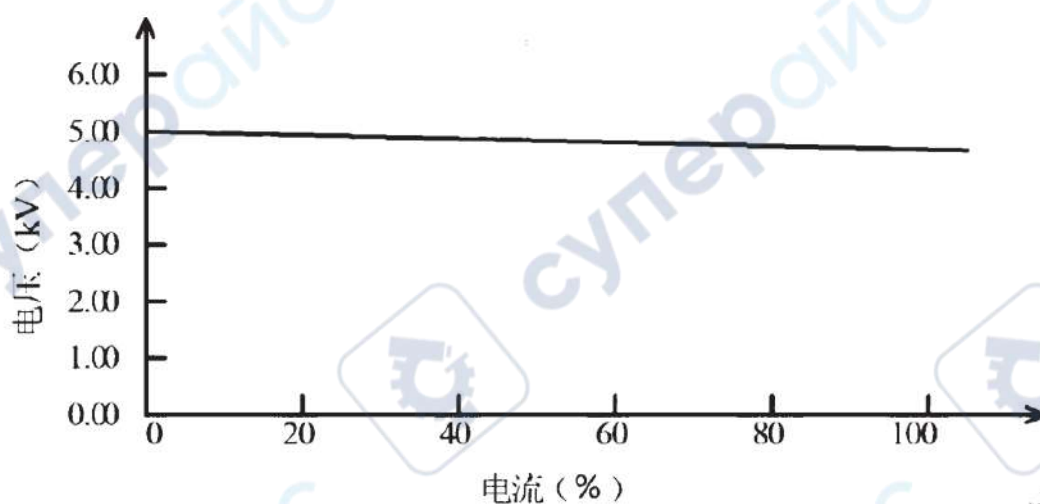

图 3-4 RK9920/A 直流电压输出范围

■ Insulation resistance test is 0.050kV to 1.000kV (1V resolution) /0.1M Ω to 10.0G Ω , with a maximum rated current RK9 920 of 10mA and 9910 of 5mA.

Insulation resistance test range:

When the voltage is less than 500V: 0.1M Ω ~ 1G Ω , the accuracy is+[10% reading+5 words]

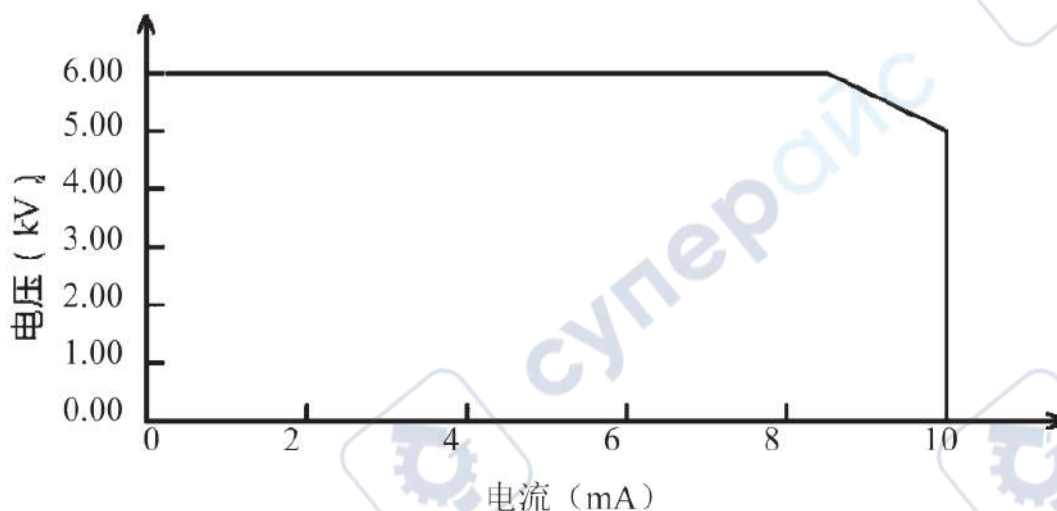
When the voltage is greater than 500V, the accuracy in the range of 0.1M Ω ~ 100M Ω is+(5% reading +5 words), and the accuracy in the range of 100M Ω ~ 1G Ω is+(10% reading +5 words).

■ RS-232C interface as standard

In addition to power conversion, key lock and other functions, other can be remotely controlled. Test conditions such as test voltage, judgment function and test time can be controlled remotely in DC withstand voltage test, AC withstand voltage test and insulation

resistance test. The test results can also be read from behind by remote control.

RS-232C and RS485 interfaces provide stable and unified standard tests with PC or other equipment.

■ **HANDLER interface and input signal interface convenient for connection control**

HANDLER interface: you can input START and STOP signals and output TEST, PASS and FAIL signals. Can be conveniently connected with a foot switch for foot control, and can be connected with a simple test fixture to realize safety interlock, pneumatic control, test indication and the like.

Input signal interface: INT LOCK signal can be input and 24V and 0.5A power output can be provided for convenient control and connection.

■ **USB interface instruments used for backup**

USB interfaces which can save the test plan and customer measurement files written by the instruments to the external U-disk, or transfer the instruments from the U-disk, so as to facilitate batch setting of the operating parameters and archiving plan of the instruments.

■ **Rise Time Control Function**

During AC withstand voltage test, DC withstand voltage test and insulation resistance test, the test voltage can slowly rise to the set value instead of providing the set voltage to the tested piece immediately after the test is started. Voltage rise time 0.1s to 999.9s The resolution is 0.1s.

TH9310/20 series conforms to UL's various test standards and IEC's voltage tolerance test standards (the initial voltage is less than half of the test voltage and the rise time can be specified when the set test voltage is reached).

■ Drop Time Control Function

In the qualification judgment of AC withstand voltage test, the test voltage can be gradually reduced. The voltage drop time can be set between 0.1s and 999.9s with a resolution of 0.1s.

■ Discharge function

Under normal circumstances, the tested piece is capacitive. At the moment when the DC withstand voltage test and insulation resistance test are cut off, the tested piece remains fully charged, thus there is a risk of electric shock. RK9 910/20 series has strong resistance to tested parts after DC withstand voltage test and insulation resistance test are completed to make fast discharge function.

■ Enhanced security

In order to improve safety, RK9910/20 series is equipped with many facilities and safety functions, including safety output terminal, discharge function and ground current detection. The so-called ground current detection means that the local high voltage test circuit cuts off the high voltage output when the return current through the casing is greater than 0.45mA.

■ High test accuracy

RK9 910/20 series voltage digital display has a voltage test accuracy of (1% reading +5V) during voltage withstand test and (1% reading +2V) during insulation resistance test. The accuracy in voltage and current withstand test is +(1% reading +5words).

■ Simple operability

RK9 910/20 series is easy to operate, ensuring that users do not have any difficulty in starting to use. This instrument lists all test parameters in the setting interface. Use the direction keys to select a parameter from the LCD display interface, and then the function button to modify the parameter. After the customer sets the data, the user can directly carry out measurement.

■ 16M FLASH, each with 50 test items.

Can edit 20 test files, corresponding to various test project combinations required by customers; Each test file can have up to 20 test items, the test items are AC withstand voltage test, DC withstand voltage test, insulation resistance test, and the test conditions of each item are not related to each other.

The stored files of the instrument can be transferred to a computer or another computer through an external U disk in the file operation interface.

Option function description:

■ High voltage output of rear panel (optional)

The rear panel includes an optional high voltage output, which provides a convenient solution for installing instrument wiring on the cabinet.

Warning: This instrument uses a high voltage of 5kV AC/DC. Therefore, do not touch the tested piece and the test line at will, which will lead to the danger of electric shock.

Around the tested piece, safety measures like fences shall be provided to ensure the safety of users. In addition, in order to ensure safety, extreme care is taken to prevent improper connection and high voltage of operation output.

Chapter 4 Basic Operation

4.1 Overview of Instrument Interface Structure

This chapter describes the operating procedures for voltage resistance and insulation resistance tests. The interface structure of the instrument is shown as follows:

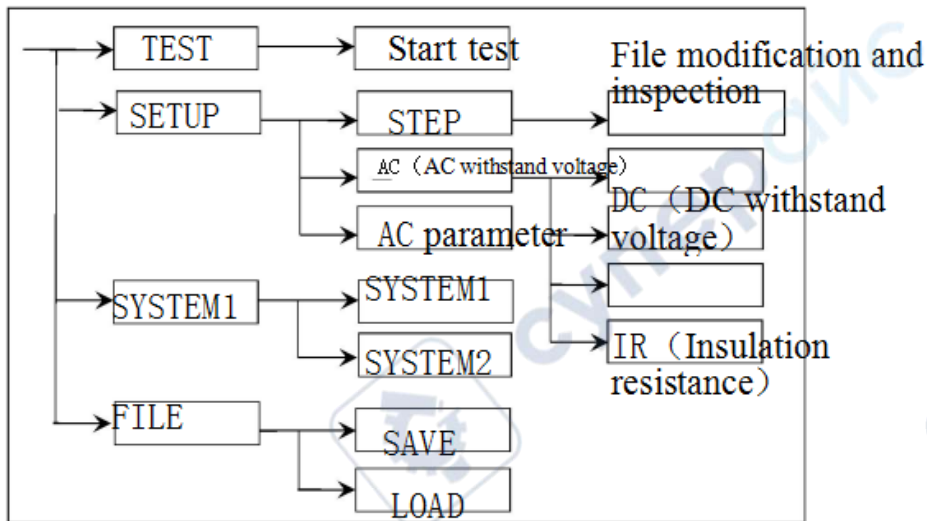

Test operation flow diagram

Interface description:

4.1.1 The first column of the writing interface structure is written based on the initial state of panel function key call (specific interface parameters are described in detail in the following chapter). Parameters cannot be modified in TEST interface.

4.1.2 The second column of the interface structure is the parameter structure of the initial interface.

For example, the default STEP of SETUP interface is scheme step 1, total step number 1.

AC: AC Voltage Withstand Test Interface.

AC Parameters: Other parameters are AC withstand voltage test parameters.

4.1.3 The third column of the interface structure is the function switching interface. When some function identifiers are selected in the second interface, these functions can be changed, and the relevant parameters of this interface will be changed. If AC is changed to DC, the instrument will change the AC withstand voltage test mode to DC withstand voltage test mode, and the 'AC parameter' of the current interface will become the 'DC parameter' that needs to be set for DC withstand voltage.

1. Press and hold the STOP and START keys at the same time to turn on the power again, and the instrument will restore the factory default settings.
2. The clearance range is: (SETUP) test conditions, (SYSTEM) system settings.
3. This method can be used to restore the normal operation of the instrument when the software of the instrument is upgraded or the display error is caused by calling the archive with low version of the document.

4.2 Panel Function Interface and Parameter Description

This section mainly introduces the functional interface and related parameters of the instrument according to the sequence of software flow and interface correlation. In order to guide users to understand the

function and use of the instrument.

Description of initial state of instrument

1. After start up, the system defaults to the last modified setting interface.
2. The factory settings of the instrument are single step, AC voltage withstand and default parameter state. The figure is as follows.
3. The default cursor of the default interface is interface switching. You can directly select other interfaces.

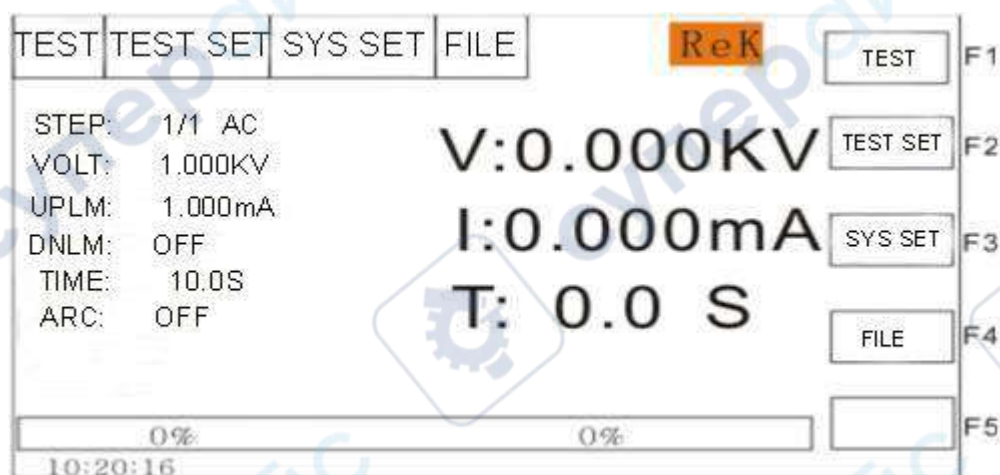

The interface switching of the instrument can be directly switched with four function keys. They are measurement display (TEST), measurement SETUP (SETUP), SYSTEM interface (SYSTEM) and FILE processing (FILE). The following describes the functions of the interface respectively.

Description of basic functions of panel keys:

TEST (test key): Let the instrument enter the test waiting state and

prepare to start the high voltage test.

SETUP (setup key): modify the interface of current test plan, test items and test parameters. The modification of the test plan is completed in this interface.

SYSTEM (System Key): The settings related to test safety and instrument working mode have little to do with the test scheme.

FILE (file key): the interface for saving and calling out the test scheme is related to the data storage.

(direction key): the cursor can be moved freely between various parameters.

F1 ~ F5 (soft keys): cooperate with the contents of the soft key function display area to modify the object selected by the cursor.

4.2.1 SETUP measurement setup. The interface schematic is as follows:

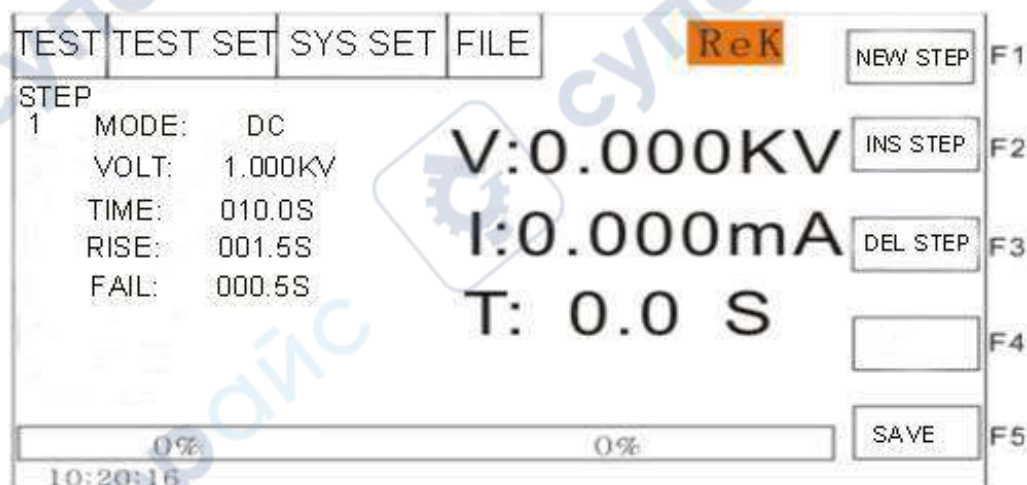

Description of Modification of Test Plan

STEP: 01/01 Test Step: Currently set item number/total number of test items.

The project identification of the test plan. The current parameter is the number of projects/total number of projects in the test plan.

Button	function	Chinese	description
F1	NEW	New	Create a new empty test plan (STEP), the system will automatically create a new default test project. Pay attention to saving after writing your own test plan.
F2	NEW	insert	A new test project was added after this project. The current and subsequent items will move backward One person.
F3	DEL	delete	Delete the current test project. Subsequent items will be moved forward by one.
F5	Save as file		Save test parameters

The working mode of AC current test step is AC withstand voltage.

The working mode of the current test project is AC withstand voltage.

When the optical marker is in this position, it can be switched to DC, IR and project by coding rotary potentiometer.

Refer to "4. 3 Test Project Interface and Parameter Description" for details of parameter modification of test project.

Note:

For ease of use, when "test protection" is OFF.

Press the 'start' key in this interface to directly enter the test interface and start the test according to the currently set test scheme.

If the operation of "start" may be triggered by mistake, please pull out the "INTLOCK" jumper before modifying the parameters to avoid danger.

4.2.2 TEST test interface. The interface schematic is as follows:

(take AC as an example)

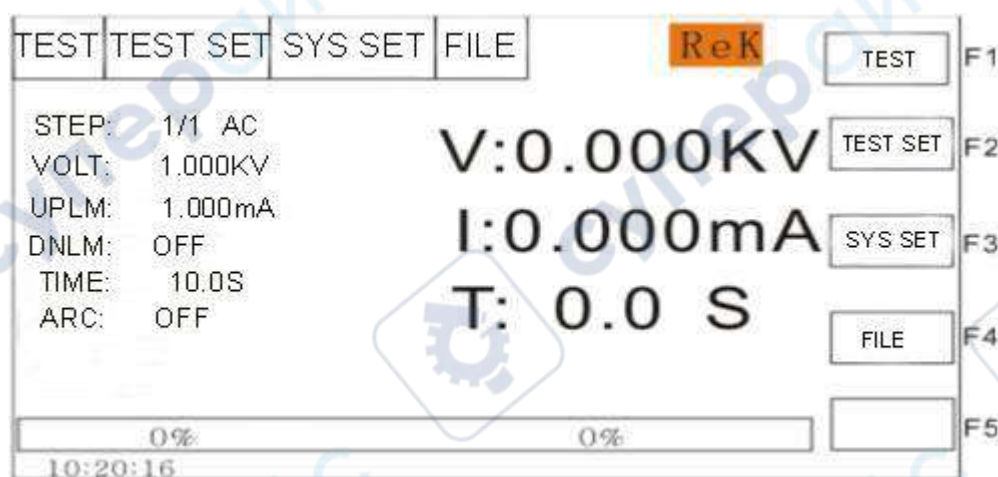

Note:

1. High voltage can be started in this interface to measure the high voltage of the tested element. Its test parameters must be set in detail and correctly in the setting interface.
2. Press F2 in this interface to quickly switch to the SETUP interface.
3. The keyboard can be locked by the function key. After the keyboard is locked, the instrument will only respond to the START, STOP and (unlock) keys.

After starting the measurement, three data are displayed in large font in the middle of the instrument panel. The real-time test data is displayed in the test, and the results of the last test are displayed before the STOP key is pressed after the test.

The upper one is the high voltage output voltage, and the withstand voltage is in kilo volts (kV).

The middle one is to test the measured current at the low end, in milliamperes (mA) and microamperes (uA).

The lower one is the remaining time of the corresponding step in high voltage test. If the user turns off the test time, the test time shows the time after entering the test state, and the count will not be accumulated after it is greater than 999.9. If it is not FAIL, the test status must exit with STOP. The user can intuitively analyze the test situation of the tested object. In seconds (s).

In general, if "FAIL" occurs, the waiting instrument will wait for "STOP OUT" to exit FAIL Status.

For ease of use, when "testing protection" OFF. The instrument will automatically exit the "Fail" state. Please pay special attention when using it.

Special reminder:

When the instrument is on, the operator must not leave the test station!!!!

During the process of high voltage test, no one is allowed to approach the test line or the tested equipment of the instrument!!!!

Non-operators shall not approach the voltmeter with the power on to avoid danger of transmission!

4.2.3 System interface. The interface diagram is as follows:

The system interface is to set some settings that are not related to the parameters of specific test components but related to the testing scheme of the instrument.

1. SYSTEM1 interface

< system setup 1 >

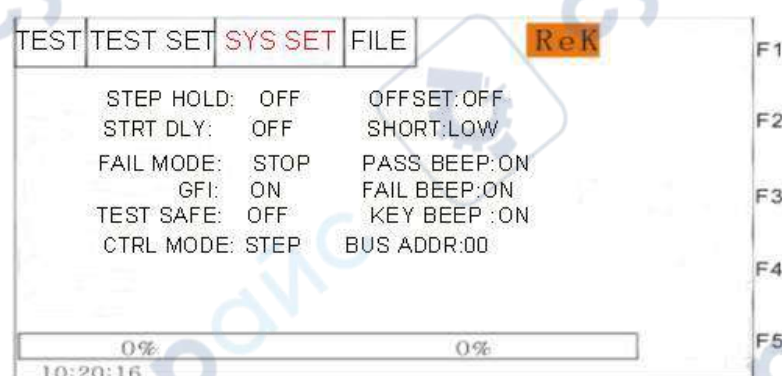

Description of interface parameters:

english	Set flag	Parameter value description	meaning
Failure mode	FAIL MODE	STOP	Exit directly when not qualified
		CONTINUE	Continue the test when it fails, and the results are output on the form
		REST	If it fails, press START to retest Current failed step
		NEXT	If it fails, press START to continue testing step.

Electric shock protection	GFI:	ON、OFF	Ground current detection, enable
Item-to-item hold	STEP HOLD	0.2S~99.9S	Wait time between projects during multi-project testing.
		OFF	Don't wait between projects
		KEY	Pause, press 'START' to start the next item
Test protection	TEST SAFE	ON	FAIL status must be returned to wait status with STOP, In order to start the next test with START.
		OFF	FAIL status automatically returns to wait status, use START Start the next test directly.
Control mode:	CTRL MODE	FILE	When the test file ends, the HANDLER interface outputs the test. Test results.
		STEP	At the end of each step, the HANDLER interface outputs Test results from previous steps.
Qualified voice	PASS BEEP	OFF	shut down
		ON	OPEN
Key sound	KEY BEEP	OFF	Turn off the button
		ON	On button sound
Zero setting	OFFSET	OFF	Start testing as soon as the default instrument is ready
		OFF~ON	The base number is set to zero.
		GET	Get the test base under the current test conditions.
Short circuit threshold	SHORT	LOW	Short-circuit response sensitivity: low
		HIGH	Short-circuit response sensitivity: high
Bus address:	BUS ADDR	0-31	Address when the instrument is transferred to the bus

<System Settings 2>

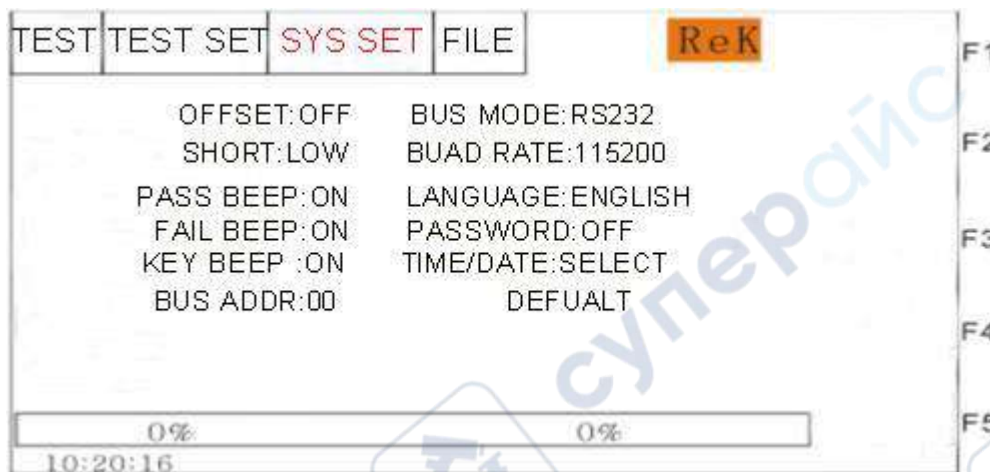

Description of interface parameters:

SYSTEM2 interface

Interface parameter description:

English	Set flag	Parameter value	description	meaning
Bus mode	BUS MODE	RS232C	Serial mode: Data format: 8.n. 1	
		RS485		
Baud rate	BAUD	9600~115200	Serial bus baud rate.	
default setting	DEFAULT		Restore the factory system settings.	
LANGUAGE	LANGUAGE	Chinese/English	Instrument interface language selection.	
Password setting	PASSWORD	OFF	Disable the password function. The default password is 9920.	
		SYSTEM	A password is required to boot into the system.	
		FILE	File calls require a password.	
		Modify	Change the old password to the new password.	

4.2.4 FILE File Storage Interface

Press (FILE key) to enter the file management interface as follows:

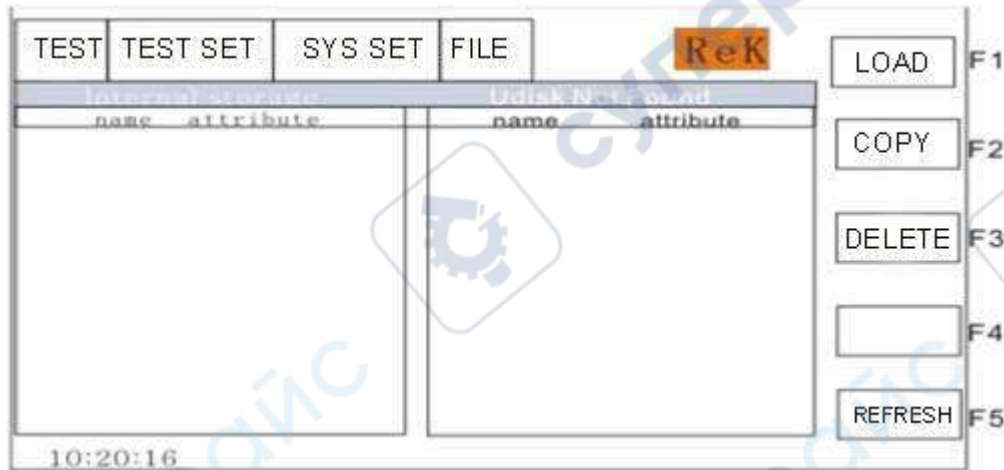

Description of interface structure:

Serial Number	Chinese Description	Shortcut Option	Chinese Meaning
1	Internal storage		internal file interface
	Extenal storage		external file interface
2	File List	F1	Calls Current File as Internal Use File
		F2	Copy Current File and Save to U Disk
		F3	Delete Current File
		F5	Refresh Display
			Page Up of File List
			Page Down of File List

4.3 Test Project Interface and Parameter Description

This section introduces the test function parameters of the setting

interface and their meanings, so as to guide customers to set relevant parameters.

4.3.1 AC withstand voltage test parameter setting.

The setting interface is as follows:

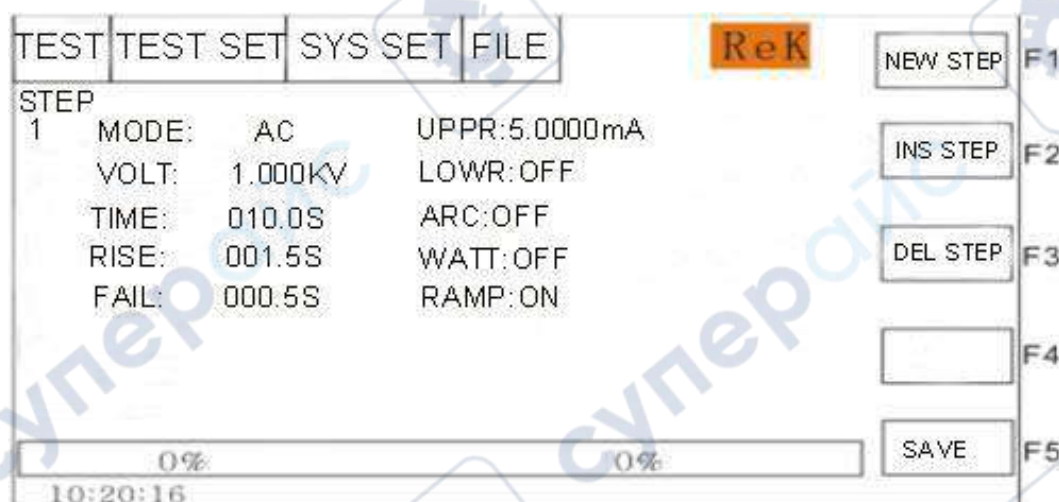

Figure 4.3.1 AC setting interface

Description of AC withstand voltage (AC) test parameters:

VOLT :	0.050~5.000kV	AC high voltage test voltage
UPPER :	0.001~20.00mA	RK9920 series AC withstand voltage and current upper limit
	0.001~10.00mA	RK9910 series AC withstand voltage and current upper limit
LOWR :	0.001~20.00mA	R K9920 series AC lower limit current value, Must be less than the UPPER value.
	0.001~10.00mA	R K9910 series AC lower limit current value, Must be less than the UPPER value.
	OFF	No lower limit required
ARC :	1.0 ~ 20.0 mA	Maximum allowable AC arc current
	OFF	No arc required
TIME :	0.1 999.9S	AC withstand voltage test time, the test ends when the time is up RISE ≠ OFF
	OFF	Unlimited test time

RISE :	0.1~999.9S	AC high voltage test voltage rise time
	OFF	Default = 0.1S, test time> 0.2S.
FALL:	0.1~999.9S	AC high voltage test voltage drop time
	OFF	Directly cut off the voltage output after the test. (DUT may be charged)
FREQ :	50/60 Hz	AC working frequency

4.3.2 DC DC withstand voltage test parameter setting.The setting interface is as follows:

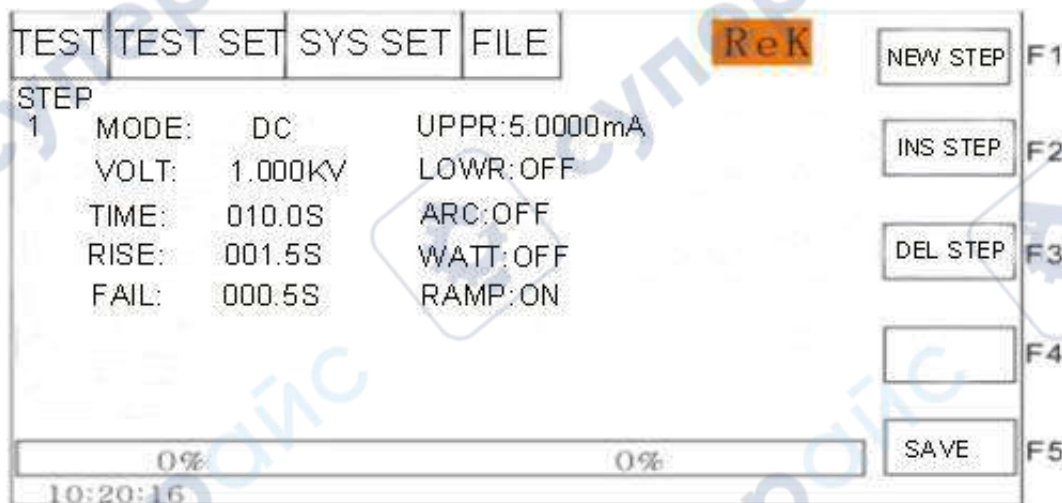

DC withstand voltage (DC) test parameters are described as follows:

VOLT :	0.050~6.000kV	DC high voltage test voltage
UPPER :	0.1 uA~10.00mA	RK9920 / A DC withstand voltage and current upper limit
	0.1 uA~5.00mA	RK9910 / A DC withstand voltage and current upper limit
LOWR :	0.1 uA~10.00mA	RK9920 / A DC withstand voltage and current lower limit, Less than UPPER value.
	0.1 uA~5.00mA	RK9910 / A DC withstand voltage and current lower limit, Less than UPPER value.
	OFF	No lower limit required
TIME:	0.1~999.9S	DC withstand voltage test time, the test ends when the time is up, RISE \neq OFF
	OFF	Unlimited test time

RISE:	0.1 999.9S	DC high voltage test voltage rise time
	OFF	Default = 0.1S, test time > 0.2s
FALL:	0.1- 999.9S	DC high voltage test voltage fall time
	OFF	At the end of the test, the voltage output is directly cut off, and it enters 0.2S to discharge quickly.
WATT:	0.1~999.9S	DC charging wait time.
	OFF	Components do not need to be charged
ARC:	1.0 ~ 20.0 mA	DC Arc Current Max
	OFF	No arc required
RAMP :	ON	Voltage rise time and current upper limit judgment are allowed.
	OFF	Voltage rise time, does not detect upper current limit, but The current limit judgment is still judged.

4.3.3 IR Insulation Resistance Test Parameter Setting.

The setting interface is as follows: (Schematic Diagram 4.3.3):

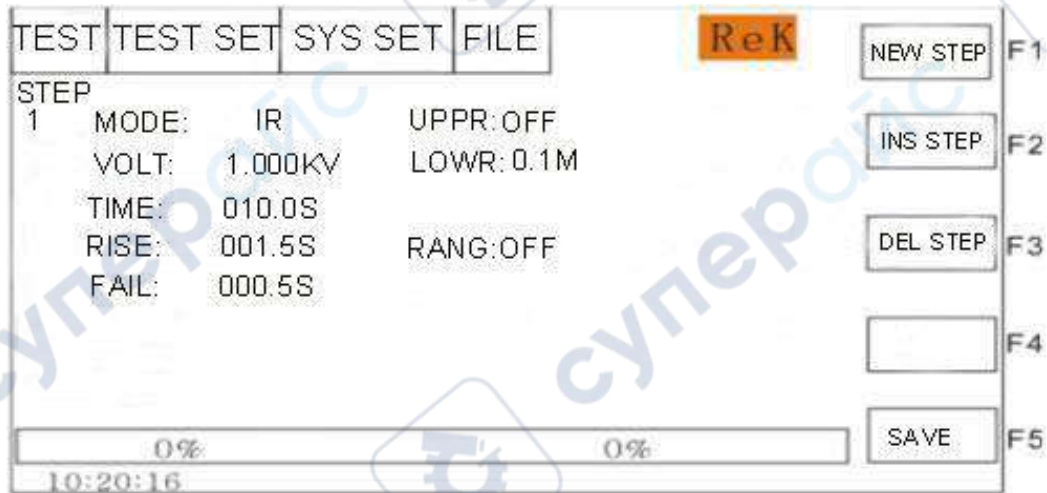

The insulation resistance (IR) test parameters are described as follows:

VOLT :	0.050~1.000kV	Insulation test voltage value.
UPPER :	0.1 M~10.00G	Upper limit of insulation resistance.
	OFF	Do not judge the upper limit of insulation resistance
LOWR :	0.1M~10.0G	Lower limit of insulation resistance, less than UPPER value.
TIME:	0.1~999.9S	Insulation resistance test time. (RISE \neq OFF)
	OFF	The test time is unlimited.
RISE:	0.1 999.9S	Rise time of insulation voltage.
	OFF	Default = 0.1S, test time > 0.2s.
FALL:	0.1- 999.9S	Insulation voltage fall time.
	OFF	After the test, directly cut off the voltage output and enter 0.2S fast discharge.
RANG:	AUTO	Auto range mode: improve test accuracy.
RK9920 series	1.0 ~ 20.0 mA	DC Arc Current Max
	OFF	No arc required
RK9910 series	2uA、20uA、200uA、 2mA 10mA	
	1uA、10uA、100uA、 1mA、5mA	

Note:

1. During charging and testing, only SHORT FAIL will respond, and judgment will be made only when the lower test limit is judged at the end of the test. Please pay attention to it!!!
2. During RANG AUTO, the test time is 0.6S minimum due to range switching. Please pay attention to it!!!
3. As the current acquisition lags behind the voltage acquisition by about 20mS, the voltage rise time shows a small resistance value and the voltage fall time shows a large resistance value, which is hereby explained for reference.

4.4 Test Function Principle and Instructions for Use

In this section, the principle and application of testing such as grounding connection, grounding current detection and arc detection are introduced in order of testing process.

Test flow diagram of the instrument

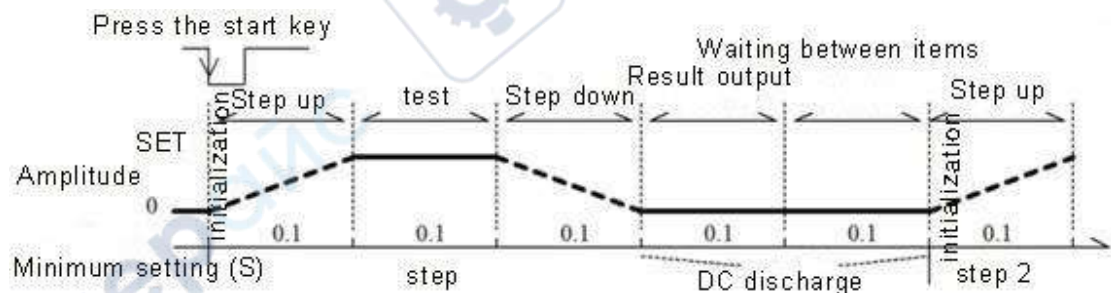
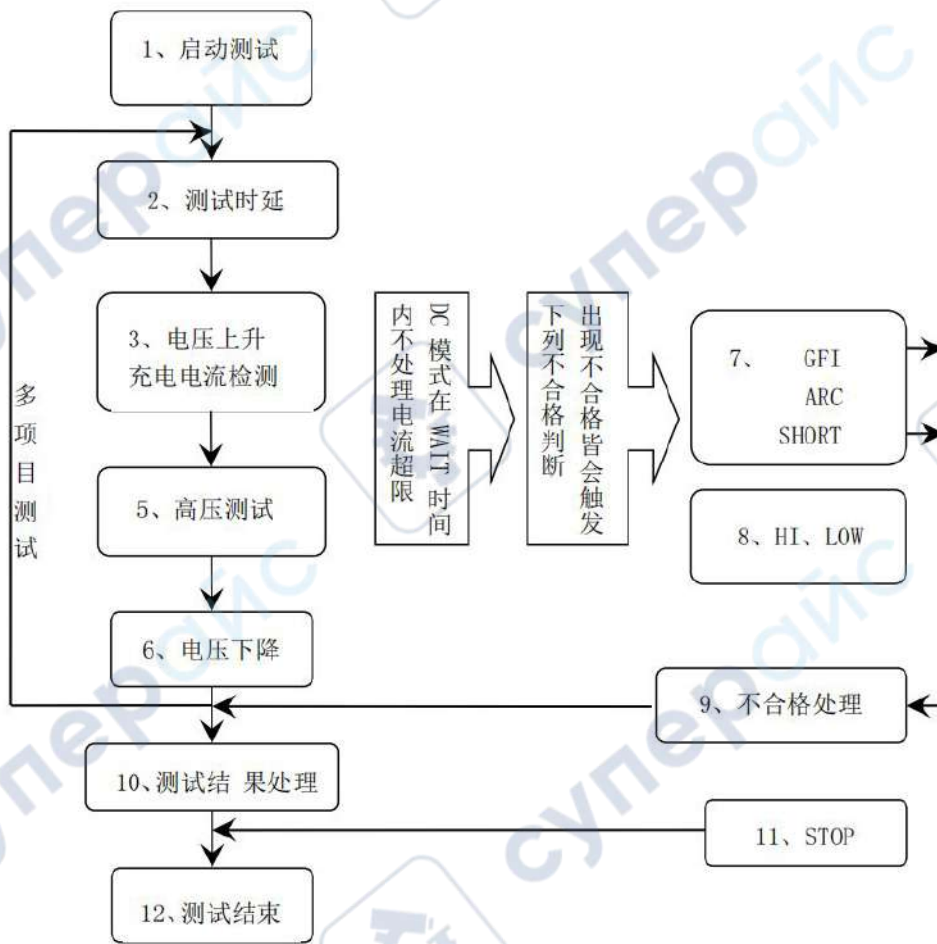

4.4.1 Start Test

When the instrument is in test mode, after checking the test conditions and connecting the tested parts correctly, press the START key to start the test.

4.4.2 Test Delay

After the test is started, the time delay before the first step is delayed according to the set delay time of the system interface. The time delay between multiple steps is maintained according to the items in the system interface.

4.4.3 Voltage rise

Some tested parts are sensitive to sudden changes in voltage and need to use this function. When the instrument starts to output, the output voltage is zero. When the output voltage starts, the instrument will control the step-up of the output voltage in units of 0.1S. The step-up value is determined according to the test voltage and the voltage rise time ($\Delta V = V / (10 * S)$). If the off voltage rise time (RISE OFF) default voltage rise time is 0.1 seconds, the test time is automatically added to make the minimum value of the test time 0.2S. This value is too small and may cause errors in ARC or DC boost determination. Please note.

4.4.4 DC boost determination

Whether to start the current upper limit judging function switch in the process of voltage rise is mainly used to avoid misjudgment in testing.

When the test distribution capacitance is small and the charging current of the capacitance is relatively small and does not cause obvious change in current, turning on boost determination can find out the bad performance of the tested piece as early as possible and reduce the over-current damage probability of the component.

When the step-by-step capacitance is large, the capacitance will have a charging process during the voltage rise, and the current at this time may be far greater than the set upper limit of the current to be measured. If the boost determination is turned on, it will cause misjudgment over the upper limit. If necessary, the short circuit threshold can be turned on to reduce the short circuit sensitivity and improve the charging current.

4.4.5 high voltage test

Carry out high voltage test on the tested piece. At this time, it should be possible to ensure that the test circuit is correct, the test results will not be affected by some special attached parameters, and the display content is the actual withstand voltage current required for the test.

4.4.6 Test Voltage Drop

The same test voltage rise is determined by the characteristics of the tested piece. When the high voltage test ends the voltage drop, the instrument will control the output voltage drop in units of 0.1S (DC voltage will not drop with the control voltage), and the step-by-step voltage drop value is determined according to the test voltage and the voltage rise time ($\Delta V = V / (10 * S)$). The default voltage drop time is 0.1 seconds if the shutdown voltage drop time (FAIL OFF). At this time, the instrument will make no test comparison and judgment, and the data are for reference only. When the voltage drop is over, the instrument will connect the test circuit to AC withstand voltage mode. At this time, if there is a DC voltage drop in the tested piece, it will discharge through the instrument AC circuit.

4.4.7 Ground wire current detection function

Ground current detection is to detect the current flowing through the instrument casing to prevent electric shock. When high voltage is output, current flows back to the instrument housing from the voltage output through the human body, which may cause very serious consequences.

Response description of the instrument's ground current detection and judgment circuit:

Local line current detection is enabled. If the ground current is greater

than 0.45mA, it is judged that the ground current exceeds the limit.

When judging electric shock, the instrument will end high voltage output within 0.3S seconds and exit the test state. And display (GFI FAIL).

Note: The instantaneous output current of the instrument may be greater than 30mA. If it is indeed an electric shock, it may cause coma or death of the operator.

Therefore, it is recommended to turn on the ground current detection when the product allows.

4.4.8 Current Overrun and arc detection function

Current overrun classification: current lower limit, current upper limit, current overrun, arc detection.

Current Lower Limit Judgment (LOW): Generally used for testing low-end disconnection judgment. When the instrument tests the equipment, the equipment will definitely have a certain leakage current. When the leakage current tested by the instrument is less than the lower limit set current value, the test is deemed to have failed (there is no equipment connected). If the leakage current of the tested element itself is very small, this function must be turned off. LOW FAIL is displayed when exceeding the limit. This determination is valid only in the test mode.

Sampling is carried out regularly at a rate of 100mS each time.

Current limit judgment (HIGH) : the most commonly used test current overrun judgment. When the instrument tests the equipment, the equipment will certainly have a certain leakage current. When the leakage current tested by the instrument is greater than the upper limit set current value, it is considered that the voltage resistance impedance of the equipment is not enough to fail the test. When exceeding the limit, the judgment display (HI FAIL) shall be carried out at a fixed sampling rate of 100mS each time.

Current limit determination: the current sampling determination is slow, and the sampling circuit with fast current change during insulation collapse cannot reflect it in time. If the current peak value exceeds the allowable output range of the instrument, such over-limit determination will be triggered, and SHORT FAIL will be displayed when over-limit.

Since the data cannot be collected after the current exceeds the limit, the system outputs the test results within 100mS before the current exceeds the limit. The current limit is twice the allowable output current of the instrument (1.5 times the peak value relative to AC). Falling time is invalid.

This determination is not maskable.

ARC Detection (ARC): It is a very practical function for measuring coil components. It tests local current oscillation caused by instantaneous discharge of local circuit in high voltage test circuit. Due to superposition

on the normal test current and short mutation time, the above ordinary current detection circuit cannot make appropriate judgment in response to current changes. The arc detection circuit filters out the normal current value and only processes the high-speed current pulse change. Due to the randomness of low-pass filtering and arc size, this function can only estimate the extent of local ignition. Since data cannot be collected after the current exceeds the limit, the output result at this time is the last test result when the current is qualified, and ARC FAIL is judged and displayed when the current exceeds the limit. ARC current is a qualitative analysis for testing. The magnitude of the quantity and the testing environment, the distribution of testing lines, etc. have great influence on randomness. Pay attention when using.

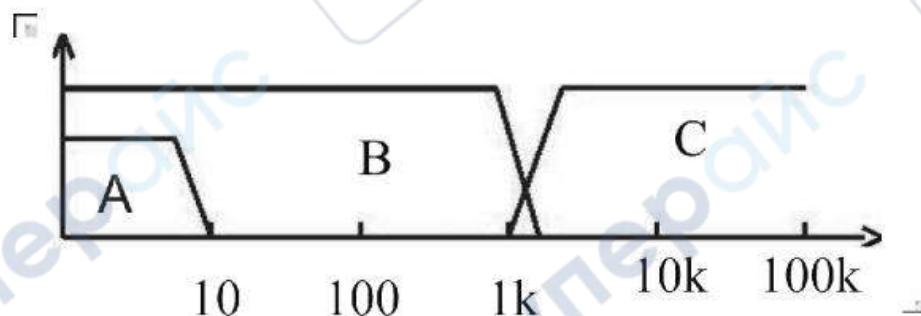

Area A in the figure: shows the frequency response of the current sampling display circuit. Because the ripple of the power frequency must be filtered out \rightarrow AD sampling \rightarrow Calculation of test results \rightarrow Analysis of whether the current exceeds the set limit. Within the test current range, the pulse width is greater than 100mS.

Area B in the figure: current fast response circuit. It only filters out high frequency interference signals → voltage peak value comparison → overcurrent peak value signal locking, and only makes limit judgment. It is larger than the allowable output current of the instrument, and the pulse width is larger than 1 ms.

Area C in the figure: arc detection circuit. The arc detection circuit only samples the amplitude of abrupt change in current, and the signal is high-pass filtered to remove low frequency → voltage peak value comparison → pulse locking. At the abrupt current edge near the set value, the pulse width is about 1 us-1 ms.

4.4.9 Unqualified Judgment

1. If the current exceeds the maximum output current that the instrument can bear during the test, or if the instrument finds that there is a potential safety hazard, the instrument will immediately cut off the voltage of the test loop and judge the failure after waiting for the instrument software to find out the cause of the error.
2. If the test result exceeds the limit set by the test item, the instrument will judge that the tested piece is unqualified. And immediately stop the current test, cut off the voltage output, enter the test results unqualified processing program.
3. In multi-step testing. There is one step of FAIL, and the overall test

result is FAIL.

4.4.10 Processing of Test Results

If the test process exceeds the limit, it is judged as (FAIL). FAIL occurs in the multi-step test, and the final result is FAIL.

With multiple test items, FAIL judgment processing mode is controlled by the failure mode of the system. Otherwise, the instrument will display FAIL judgment and category (see figure below for example HI), waiting for the user to process.

After the test, there is no unqualified mark, and the test result is judged as (PASS).

PASS judges that the processing mode is controlled by PASS HOLD of SYSTEM, and then prepares to start the next measurement or return to the test waiting state.

HANDLER signal output is controlled by the control mode. Select FILE mode, then the test results will not be output until the whole file test is finished. The STEP mode controls the interface to output corresponding signals in each step.

From this state to the next step, the customer can use software to query the test data and results.

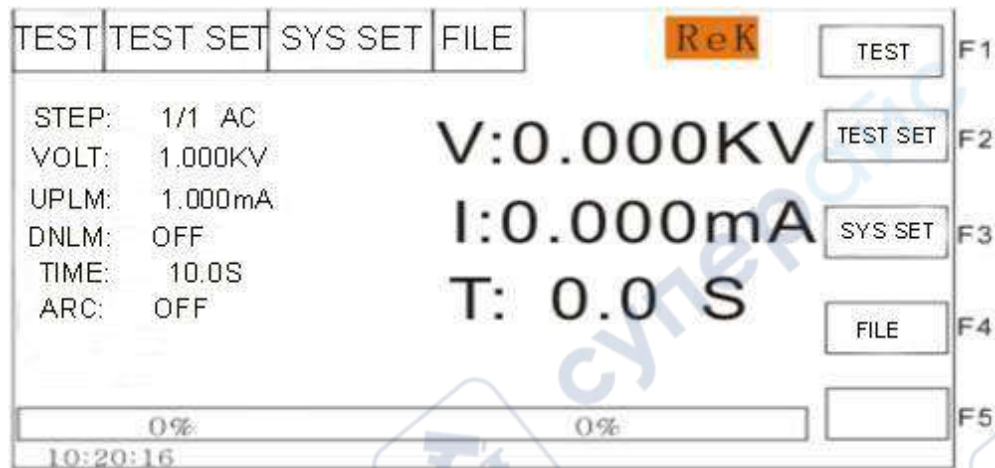

4.4.11 STOP (Stop Measurement)

Press the 'STOP' key at any state during the whole test process, and the instrument will automatically end the test and enter the test end state. Press the 'STOP' key again, and the instrument will return to the test waiting state. No test result judgment output will be given when the test is stopped.

At the end of the test, the customer can use software to query the last test data obtained before 'STOP'.

4.4.12 OFFSET (base cleared)

Before the test, due to changes in the working environment of the instrument and the placement position of the test cable, some bases may appear during the no-load test of the instrument. Customers requiring accurate measurement can be cleared in the SYSTEM interface.

The specific operation steps are as follows:

1. Set the current test conditions in the SETUP interface.
2. Select OFFSET in the SYSTEM interface and set it to ON.
3. Press GET instrument to automatically start the high voltage test and set the current test value as zero bit value.
4. If the customer does not set the test time, the STOP key can be used to stop the test.

Note:

Do not connect the product to the test end during GET. Clearing the product to zero cannot improve the actual test range of the instrument.

OFFSET will clear all steps, please make sure the setting data is correct.

To change the test conditions, OFFSET must be done again.

4.5 HANDLER and SIGNAL Interface Circuit Structure and Use

4.5.1 Control Interface Principle

Internal principles of HANDLER and SIGNAL interface instruments, such as

HANDLER和SIGNAL接口仪器内部原理，如下：

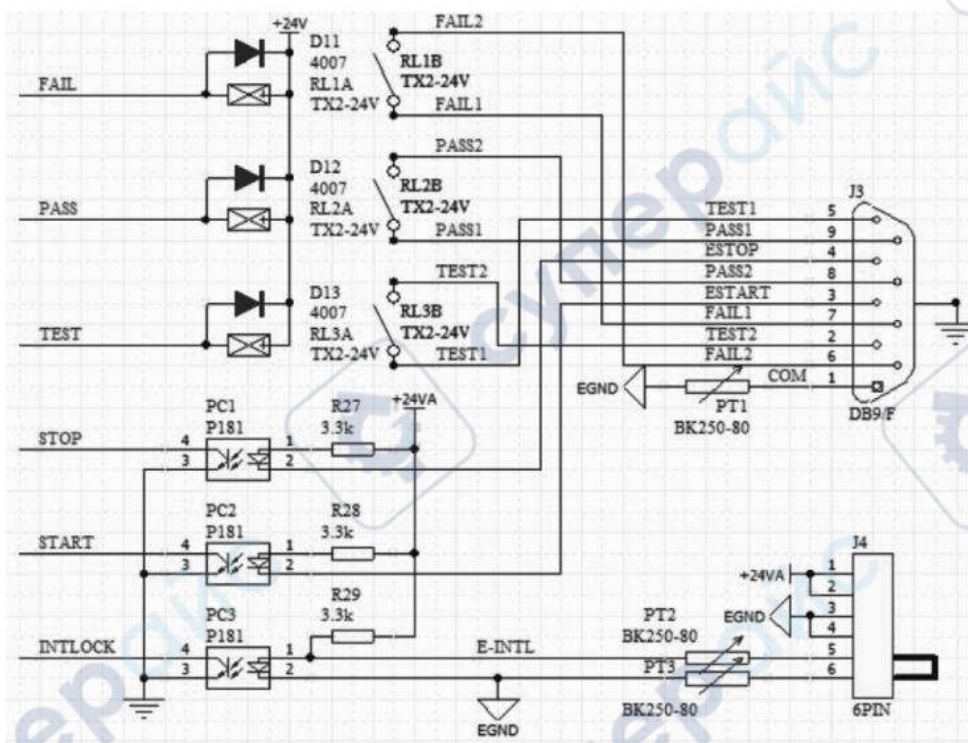

HANDLER、SIGNAL 接口结构与时序

HANDLER, SIGNAL interface structure and timing

Description:

1. HANDLER interface: signals of START, STOP and COM form remote input control, and the switch input is closed effectively.
2. HANDLER interface: TEST, PASS and FAIL signals form remote output control. The switch output is closed effectively. TEST can be used as a high-voltage starting signal or a pulse signal when the instrument works normally.
3. SIGNAL interface is mainly used to provide instrument selection signal (INTLOCK) for multi-instrument online test. This signal unit defaults to short circuit. It is forbidden to start high-voltage output of this

instrument when it is open.

4. The SIGNAL interface additionally provides a power supply with an approximate output voltage of +24V, and the output current is less than 0.5A. In cooperation with the HANDLER interface control signal, it can be used to drive indicator lights, photoelectric switches, low-power solenoid valves, etc.

(see figure below)

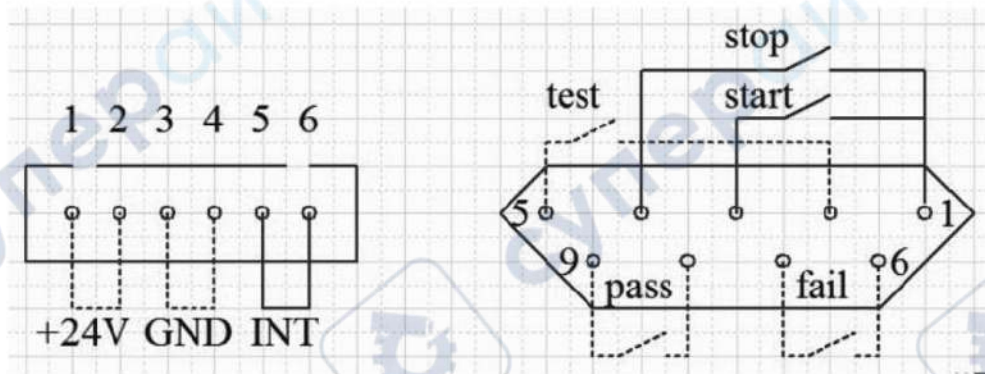

4.5.2 Use of Control Interface

The control interface is generally used for synchronization or indication of remote control and test. The external connection of the interface is as follows:



图 4.5.2: 外部电路连接示意图

Figure 4.5.2: Schematic diagram of external circuit connection

Description:

1. The switch can be replaced by isolating switch elements such as optocoupler secondary side. The current direction is based on the principle of the above figure (COM end is the low end).
2. The indicator lamp here can be replaced with other drive control components, and the current direction depends on the power supply.
3. Internal power supply performance of the instrument
 - a) It is rectified and filtered output of AC power supply. the unregulated output is about 24V. please confirm before use.

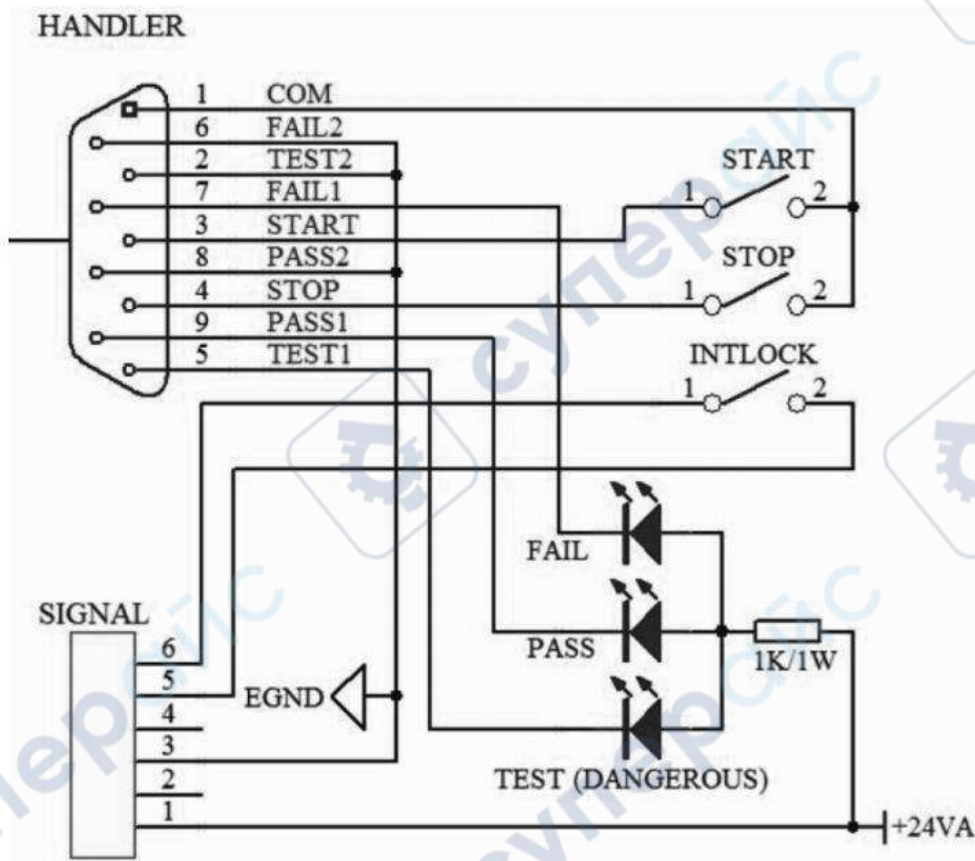
b) The instantaneous maximum value of current shall not be greater than 0.5A, and the long-term working current shall be less than 0.2a. please provide your own power supply if you need more current.

c) The external control signal needs a voltage greater than 220V or a current of 2A, and the internal relay of the instrument will not be able to bear it. please transfer it by yourself.

4.6 Other Interfaces and Functions of Instruments

1. USB HOST on the front panel is used to connect USB flash drives and to export and import customer setting files.

2. The USB DEV on the back panel maps internal FLASH to the computer as a U disk.

3. RS232 is used to connect with the computer. see the system settings for baud rate and the data format is 8.n.1 ..Compatible with software format IEE485.

Chapter 5 Description of Serial Port Instruction Set

Brief description of instruction format:

1. The instrument instruction set only describes the actual characters accepted or sent by the instrument.

2. Command characters are ASCII characters.

3. Data of instructions "<???" are ASCII strings. The system default format is integer or floating point number, and the unit of data is the default value. It does not appear in the instruction.

4. The instruction end must have an instruction end tag: the identifier of the end of an instruction without which the instrument does not parse the instruction.

a) the default end marks are carriage return character (NL), print control character (\n), decimal number (10), hexadecimal number (0x0A).

b) IEEE-488 bus end tag: key word (end), signal (EOI).

Multiple instructions can simplify the sending example as follows:

Note: In the example "_" is marked with a space

```
FUNC : SOUR : STEP_1 : AC : VOLT_1000 ; UPPC_1 ; TTIM_9.9 ;  
CH1_HIGH ; CH2_LOW (NL^END)
```

```
FUNC : SOUR : STEP_INS (NL^END)
```

```
FUNC : SOUR : STEP_2 : DC : VOLT_1000 ; UPPC_1 ; TTIM_9.9 ;  
CH1_HIGH ; CH2_LOW (NL^END)
```

5.1 S C PI instruction set

Instrument Subsystem Command for RK9920/9910

- DISPlay

- SYSTem
- FUNCTion
- MMEM
- FETC

5.2 DISPLAY subsystem command set

The Display subsystem command set is mainly used to set the display page of the instrument, character? You can query the current page.

Display : PAGE

Command syntax: DISplay: PAGE <page name >

< page name > is as follows:

TEST Settings Display Page to: Measurement Display Page

TESTSET Settings Display Page to: Measurement Settings Page

SYS Set settings display page to: system settings page

FLIE Settings Display Page to: (Internal) Document List

Character You can query the current page

-Example:

Set display page to: measurement display page.

Setting instruction: DISP: PAGE TEST

Query instruction: DISPlay: PAGE?

Return value: TEST

5.3 FUNCTION Subsystem Command Set

5.3.1 FUNCTION subsystem command set is mainly used to set test parameters of instrument test function.

Command.tree

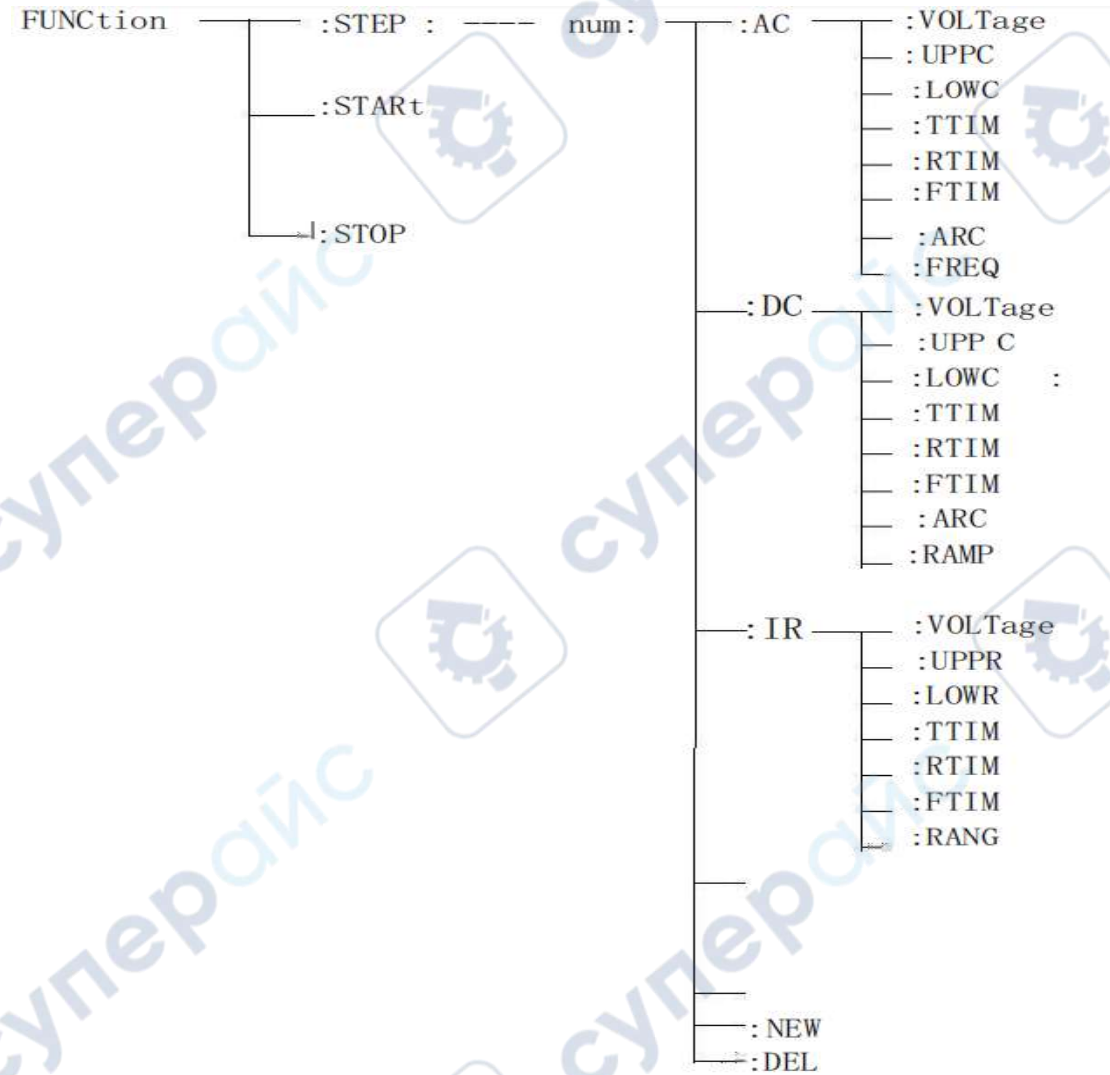

5.3.2 PROG Function Command Set

FUNC : START When the instrument is in the test interface, start the test.

FUNC : STOP When the instrument is in the test interface, stop the test.

FUNC : STEP :<num>: INS adds a new test item to the existing test plan
(step)

FUNC : STEP :<num>: DEL deletes the current test item in the existing
test plan (step).

FUNC : STEP :<num>: NEW creates an empty test scheme to write
a new test scheme

FUNC : STEP :<num>: edit the < num > step of the current test plan,
< num > = 1~50.

5.3.3 AC Setup function command set

FUNC : SOURce : STEP : AC : VOLT set/inquire the voltage of ACW

-format: setting format: FUNC : STEP :<num>: AC : VOLT
< voltage value >

Query format: FUNC : STEP :<num>: : AC : VOLT

-data<sn>data type: integer

Data range: 1~20

Data accuracy: 1

-data < voltage value >: data type: floating point number

Data range:

0.050~5 .000

Data accuracy: 0.001

-sample data unit: KV

Set the voltage of ACW in STEP 1 to: 1000V

Setting command: FUNC : STEP :<num>: AC : VOLT 1.000

Inquiry command: FUNC : STEP :<num>: AC : VOLT? ,

Return value: 1.000

FUNC : SOURce : STEP : AC : UPLM set/inquire ACW's upper limit current
-format:

Setting format: FUNC : SOURce:STEP :<num>: : AC : UPLM

< current value > query format: FUNC : SOURce:STEP :<num>: : AC : UPLM

-data < voltage value >:

Data type: floating point number

Data range: 0.001 ~20.000 mA

Data accuracy: 0.001 mA

Data unit: mA

-Example:

Set the upper current limit of ACW in STEP 1 to 1mA

Setting command: FUNC : STEP1:MODE:AC:UPLM 1.000

Inquiry command: FUNC : STEP1:MODE:AC:UPLM?

Return value: 1.000

FUNC:SOURce: STEP#:MODE:AC:DNLM set/inquire ACW's upper limit current

-format:

Setting format: FUNC : STEP#:MODE:AC:DNLM< CURRENT>

Query format: FUNC : STEP#:MODE:AC:DNLM?

-data < current value >

Data type: floating point number

Data range: 0.001~20.000 mA (where 0 is OFF) RK 9920

0.001~10.000 mA (where 0 is OFF) RK 9910

Data accuracy: 0.001 mA

Data unit: mA

-Example:

Set the lower current limit of ACW in STEP 1 to 1mA

Setting command: FUNC : STEP1:MODE:AC:UPLM 1.000

Query command: FUNC : STEP1:MODE:AC:UPLM?

Return value: 1.000.

FUNC:SOURce: STEP#:MODE:AC:ARC Set / query arc value

-format:

Setting format: FUNC : FUNC : STEP#:MODE:AC:ARC

Query format: FUNC : FUNC : STEP#:MODE:AC:ARC?

Data type: floating point number

Data range: 0.001-20.00mA

Data accuracy: 0.001

Data unit: mA

-Example:

Set the current value of AC in STEP1 to 1mA.

Setting command: SOURce: STEP1:MODE:AC:ARC 1.000

Query command: SOURce: STEP1:MODE:AC

Return value: 1.

FUNC:SOURce: STEP#:MODE:AC:TTIME Set / query AC test time

-format:

Setting format: FUNC : FUNC : STEP#:MODE:AC:TTIME

Query format: FUNC : FUNC : STEP#:MODE:AC:TTIME?

Data type: floating point number

Data range: 0~999.9 (where 0 is OFF)

Data accuracy: 0.1

Data unit: s

-Example:

Set the test time of ACW in STEP 1 to: 1s

Setting format: FUNC : FUNC : STEP#:MODE:AC:TTIME

Query format: FUNC : FUNC : STEP#:MODE:AC:TTIME?

Return value: 1.

FUNC:SOURce: STEP#:MODE:AC:RTIME set/query rise time of ACW

-format:

Setting format: FUNC : STEP#:MODE:AC:RTIME

Query format FUNC : STEP#:MODE:AC:RTIME?

-data < time value >:

Data type: floating point number

Data range: 0~999.9 (where 0 is OFF)

Data accuracy: 0.1

Data unit: s

-Example:

Set the rise time of ACW in STEP 1 to: 1s

Setting command: FUNC : STEP :<num>: AC : RTIM 1

Query command: FUNC : STEP :<num>: AC : RTIM?

Return value: 1.000.

FUNC:SOURce: STEP#:MODE:AC:FTIME Set/Query the Fall Time of ACW

-format:

Setting format: FUNC : STEP#:MODE:AC:FTIME < time value>

Query format: FUNC : STEP#:MODE:AC:FTIME?

-Example:

Set the fall time of ACW in STEP 1 to: 1s

Setting command: FUNC : STEP :<num>: AC : FTIM 1

Query command: FUNC : STEP :<num>: AC : FTIM?

Return value: 1.

-data < time value >:

Data type: floating point number

Data range: 0~999.9 (where 0 is OFF)

Data accuracy: 0.1

Data unit: s

-Example:

Set the rise time of ACW in STEP 1 to: 1s

Setting command: FUNC : STEP1:MODE:AC:FTIME 1

Query command: FUNC : STEP1:MODE:AC:FTIME ?

Return value: 1.000.

FUNC:SOURce: STEP#:MODE:AC:FREQuency freq set/query ACW test frequency

-format:

Format: FUNC : STEP#:MODE:AC:FREQuency

Query format: FUNC : STEP#:MODE:AC:FREQuency?

-data < frequency >:

Data Type: Character

Data range: 50/60

Data accuracy:

Data unit: Hz

-Example:

Set the test frequency of ACW in STEP 1 to 50Hz

Setting command:

FUNC : SOURce : STEP1:MODE:AC:FREQuency 50

Inquiry command: FUNC : SOURce : STEP1:MODE:AC:FREQuency?

Return value: 50.

5.3.4 DC Setup function command set

Note: the basic format refers to the AC Setup function command set.

FFUNC:SOURce: STEP#:MODE:DC:VOLTage set/inquire the voltage of DCW

Format: FUNC : STEP#:MODE:DC:VOLTage

Query format: FUNC : STEP#:MODE:DC:VOLTage ?

-data < voltage value >:

Data type: floating point number

Data range: 0.050~6 .000

Data accuracy: 1

Data unit: KV

Format: FUNC : STEP1:MODE:DC:VOLTage 1.000

Query format: FUNC : STEP1:MODE:DC:VOLTage?

FUNC:SOURce: STEP#:MODE:DC:UPLM Sets/Queries the Upper Current Limit of DCW

-data < current value >:

Data type: floating point number

Data range: 0.001 ~10.000 mA RK 9920

0.001 ~5.000 mA RK 9910

Data accuracy: 0.001 mA

Data unit: mA

FUNC:SOURce: STEP#:MODE:DC:DNLM set/query the lower limit current of DCW

-data < current value >:

Data type: floating point number

Data range: 0~10.0 mA (where 0 is OFF) RK 9920

0~5.0 mA (where 0 is OFF) RK 9910

Data accuracy: 0.001 mA

Data unit: mA

FUNC:SOURce: STEP#:MODE:DC:TTIME set/query test time for DCW

-data < time value >:

Data type: floating point number

Data range: 0~999.9 (where 0 is OFF)

Data accuracy: 0.1

Data unit: s

FUNC:SOURce: STEP#:MODE:DC:RTIME set/query rise time of DCW

-data < time value >:

Data type: floating point number

Data range: 0~999.9 (where 0 is OFF)

Data accuracy: 0.1

Data unit: s

FUNC:SOURce: STEP#:MODE:AC:FTIME setting/querying the drop time of DCW

-data < time value >:

Data type: floating point number

Data range: 0~999.9 (where 0 is OFF)

Data accuracy: 0.1

Data unit: s

FUNC:SOURce: STEP#:MODE:DC:ARC Set/Query ARC Current Limit for

DCW

-data < current value >:

Data type: floating point number

Data range: 0~20.0 mA (where 0 is OFF) Rk9920

0~10.0 mA (where 0 is OFF) Rk9910

Data accuracy: 0.1mA

Data unit: mA

FUNC:SOURce: STEP#:MODE:AC:RAMP Set/Query the Boost Status of

DCW

-format:

Setting format: FUNC : STEP#:MODE:DC:RAMP : <ON/OFF> or<1/0>

FUNC : STEP#:MODE:DC:RAMP ?

Query format:

-data < voltage >:

Data Type: Character

Data range: OFF(0), ON(1)

Data accuracy:

Data unit:

-Example:

Set the RAMP state of DCW in STEP 1 to: OFF

Setting command: FUNC : STEP1:MODE:DC:RAMP 0

Query command: FUNC : STEP1:MODE:DC:RAMP?

Return value: 0.

5.3.5 IR Setup function command set

Note: the basic format refers to the AC Setup function command set.

FUNC : STEP :<num>: IR: VOLT set/inquire IR voltage

-data < voltage value >:

Data type: floating point number

Data range:

0.050~1 .000

Data accuracy: 1

Data unit: K V

FUNC : STEP :<num>: IR: UPPC Sets/Queries IR Resistance Upper Limit

-data < resistance value >:

Data type: floating point number

Set/query the upper resistance limit of IR

Data range: 0~1E4 (0 is OFF) M Ω

Data accuracy: 0.1M Ω

Data unit: m ω

FUNC : STEP :<num>: IR: LOWC set/inquire lower resistance limit of IR

-data < resistance value >:

Data type: floating point number

Data range: 0.1~1E4 M Ω

Data accuracy: 0.1M Ω

Data unit: m ω

FUNC : STEP :<num>: IR: TTIM set/query IR test time

-data < time value >:

Set/Query IR Test Time

Data type: floating point number

Data range: 0~999.9 (where 0 is OFF)

Data accuracy: 0.1

Data unit: s

FUNC : STEP :<num>: IR: RTIM set/query rise time of IR

-data < time value >:

Data type: floating point number

Data range: 0~999.9 (where 0 is OFF)

Data accuracy: 0.1

Data unit: s

FUNC : STEP :<num>: IR: FTIM setting/inquiring the falling time of IR

-data < time value >:

Set/Query IR Fall Time

Data type: floating point number

Data range: 0~999.9 (where 0 is OFF)

Data accuracy: 0.1

Data unit: s

FUNC : STEP :<num>: IR: RANG setting/querying IR range

-data < range value >:

Data Type: Integer

Data range: 0~5 (where 0 is AUTO, 1 is 10mA, 2 is 2mA, 3 is 200uA.

4 is 20uA, 5 is 2uA.)

5.4 SYSTEM Subsystem Command Set

Command tree:

SYSTem	:	FAIL?
	:	FAIL
	:	GFI?
	:	GFI
	:	SHORT?
	:	SHORT
	:	PBEEp?
	:	PBEEp
	:	FBEEp?
	:	FBEEp
	:	KBEEp?
	:	KBEEp
	:	BKLigh?
	:	KLigh
	:	LANGuage?
	:	LANGuage

SYSTEM : DELAY setting/query start-up delay

-format:

Format: SYST: Delay < time value >

Query format: SYST: Delay?

-Data:

Data type: float

Data range: 0.1~99.9

Data accuracy: 0.1

Data unit: s

-Example:

Set DELAY to 1.0s

Set command: SYST: DELAY 1

-return information

Query command: SYST: DELAY?, return value: the setting value of START

DELAY, such as 1.000

SYSTEM:STEP Sets/Queries Interval for STEP

-format:

Setting format: SYST: STEP < time value >

Query format: SYST: STEP?

-Data:

Data type: float

Data range: 0.1~99.9

Data accuracy: 0.1

Data unit: s

-Example:

Set STEPHOLD to 1.0s

Set command: SYST: STEP 1

-return information

Query command: SYST: STEP?,

return value: the set value of STEPHOLD, such as 1.000

System : GFI setup/query status of GFI.

-format:

Setting format: syst: gfi < on/off > or < 1/0 >

Query format: SYST : GFI?

-data < ON/OFF >:

Data Type: Character

Data range: 0 (OFF) ,1 (ON)

-Example:

Set GR CONT to ON

Set command: SYST:GFION or:SYST: GFI: 1

-return information

Query command: SYST: GFI?, return value: status of GR CONT,
such as 1.

System : FAIL set/query AFTR FAIL status

-format:

Format: SYST : FAIL <0/1/2/3>

Query format: SYST : FAIL?

-data < STOP/CONT/REST/NEXT >:

Data Type: Character

Data range: 0~3

-Example:

SET AFTR FAIL TO STOP

Set command: SYST : FAIL 0

-return information

Query command: SYST : FAIL?, return value: status of AFTR FAIL,
SUCH AS 0.

SYSTEM : LANGUAGE setting/query language status

-format:

Format: SYST: LANG < 0/1 >

Query format: SYST : GFI?

-data < ON/OFF >:

Data Type: Character

Data range: 0 (Chinese), 1 (English)

-Example:

Set LANG to 0 (Chinese)

Set command: SYST : LANG 0

-return information

Query command: SYST : LANG? , return value: the state of LANG, such as 0.

System : PBEE /FBEE/KBEE Settings/Query Test Passed/Failed/Key Buzzer Status

-format:

Setting format: SYST : PBEE <ON/OFF> or<1/0>

Query format: SYST : PBEE?

-data: <OFF/ ON >

Data Type: Character

Data range: 0 (OFF) ,1 (ON)

-Example:

Set BEEP to 1

Set command: SYST : BEEP 1

-return information

Query command: SYST : BEEP? , return value: buzzer status, such

as 1.

SYSTEM : OFFSET setting/query reset setting

-format:

Setting format: SYST : OFFS<ON/OFF/GET> or<1/0/GET>、

Query format: SYST : OFFS?

-data < ON/OFF/GET >:

Data Type: Character

Data range: 0 (OFF) ,1 (ON) ,GET (get clear value)

-Example:

Set OFFS to ON

Set command: SYST : OFFS ON 或者: SYST : OFFS 1

-return information

Query command: SYST : OFFS? , return value: status of OFFS, such

as 1.

-Set command: syst: offs get

System : SYST : OFFS GET

SYSTEM : RESET restores all settings to the default state

-format:

-format: SYST : RES

5.5 MMEM Subsystem Command Set

MMEM:SAVE saves the current file to the file number.

-format:

Format: MMEM : SAVE < file name >

-data < file name >:

Data Type: String

MMEM LOAD exports the file specified by the file number to the current.

-format:

Format: MMEM : LOAD < file name >

-data < file name >:

Data Type: String

5.6 FETCH Subsystem Command Set

FETCH used to obtain the measurement results of the instrument

-format:

Setting format: FETCH : AUTO

Query format: FETCH : AUTO?

-data < ON/OFF> or <1/0 >

Data Type: Character

Data range: 0 (OFF) ,1 (ON)

-Example:

The set test data is automatically returned to ON

Command is: FETCh : AUTO ON or: FETCh : AUTO 1

-return information

Query command: FETCh?, return the current measurement results of the instrument.

Command syntax: FETCh?

After receiving this command, the instrument will automatically issue the test results until the test is finished.

Command syntax: FETCh?

After receiving this command, the instrument will automatically issue the test results until the test is finished.

Return format:

Step: Test items: test voltage (V), test current (mA), sorting results;

(1)Steps and test items.

The separator between test items and data is (:).

(2): The separator between test data is (,).The separator between different unit data is (;)

(3): The separator between steps is (:+spaces).The data terminator defaults to uyl(0x0A).

Note: 1. All data are in integer or floating point format and ASCII string.

2. The data unit is the same as FUNC setting instruction set by default.

The test results are all

STEP1 : I: 500V , test resistance 100mΩ, result PASS 。

Returned data format:

STEP1 I : 30,100,PASS ; (SPACE)

5.7 Other Control Command Sets

*IDN query instrument model, version information

Query returns: <manufacturer>,<model>,<firmware><NL^END>

Here: <manufacturer> gives the name of the manufacturer (REK)

<model> give the machine model (e.g RK9920/9910)

<firmware> gives the software version number (such as

Version1.0.0)

For example: WrtCmd("*IDN? ");

Chapter 6 Technical Parameters

6.1. Specific Parameters

model	RK9920 series	RK9910 series
screen size	5 inch TFT LCD screen	
number key	Parameter	setting digital

basic skills	input		
	Coding switch	Parameter selection and confirmation function	
	Up, down, left and right function keys	Parameter setting up and down selection function	
	LOCK keyboard lock function	Prevent accidental modification of test conditions or prohibit test conditions from being modified	
	Alarm function	Audible alarm	
	Communication Interface	RS232C、RS484	
	USB	Copy, copy, store function	
	Control interface	HANDLER(PLC)、SINGAL	
	AC	voltage range	0.050KV-5.000KV
		Voltage waveform	Sine wave

Withstand voltage test	Distortion	≤1%		
		working frequency	50Hz or 60Hz	
		Frequency accuracy	±1.0%	
		Output Power	100VA(5.000KV 20mA) 50VA(5.000KV 10mA)	
		Voltage regulation	± (1.0% + 50V) (rated power)	
	DC	voltage range	0.050KV-6.000KV	
		Signal source frequency	600Hz	
		Output Power	50VA(5.000KV 10mA) 25VA(5.000KV 5mA)	
		Voltage regulation	± (1.0% + 100V) (rated power)	
	Voltage resolution	1V		
	Voltage output accuracy	± (2.0% setting + 5V) no load		
	Voltage test accuracy	± (2.0% setting + 2V)		
	Voltage generation method	DDS signal source + AB power amplifier		
	Current test range	AC 0.001mA-20mA	AC 0.001mA-10mA	
		DC 0.1uA-10mA	DC 0.1uA-5mA	
Current accuracy	± (2.0% of reading + 5 words)	± (2.0% of reading + 5 words)		

		$\pm (2.0\% \text{ of reading} + 5 \text{ words})$	$\pm (2.0\% \text{ of reading} + 5 \text{ words})$
Insulation resistance test	output voltage	0.05KV–5.000KV $\pm (1.0\% \text{ of reading})$	
	Voltage resolution	1V	
	Voltage test accuracy	$\pm (2.0\% \text{ of reading} + 2V)$	
	Output current	10mA	5mA
	Output power	10VA(1000V/10mA)	5VA(1000V/5mA)
	Ripple (1KV)	$\leq 3\%$ (1KV no-load)	$\leq 3\%$ (1KV no-load)
	Resistance measurement range	0.1M Ω –100G Ω	0.2M Ω –100G Ω

	Resistance display range (1000V)	10mA(0.1M Ω –0.5M Ω)	5mA(0.2M Ω –1M Ω)
		2 mA (0.5M Ω –5M Ω)	1mA (1M Ω –10M Ω)
		200 μ A (5M Ω –50M Ω)	100 μ A (10M Ω –100M Ω)
		20 μ A (50M Ω –500M Ω)	10 μ A (100M Ω –1G Ω)
		2 μ A (500M Ω –100G Ω)	1 μ A (1G Ω –100G Ω)
	Resistance display range (5000V)	/	/
		500 μ A (10M Ω –50M Ω)	500 μ A (10M Ω –100M Ω)
		100 μ A (50M Ω –50M Ω)	50 μ A (10M Ω –100M Ω)
		10 μ A (50M Ω –100G Ω)	5 μ A (10M Ω –100G Ω)
	Resistance measurement accuracy	$\geq 500V$	$\geq 500V$
0.1M Ω –1G Ω $\pm (5\% \text{ of reading} + 5 \text{ words})$		0.2M Ω –1G Ω $\pm (5\% \text{ of reading} + 5 \text{ words})$	
1G Ω –50G Ω $\pm (10\% \text{ of reading} + 5 \text{ words})$		1G Ω –50G Ω $\pm (10\% \text{ of reading} + 5 \text{ words})$	
50.0G Ω –100.0G Ω $\pm 15\%$		50.0G Ω –100.0G Ω $\pm 15\%$	
<500V		<500V	
0.1M Ω –1G Ω $\pm (10\% \text{ of reading} + 5 \text{ words})$		0.2M Ω –1G Ω $\pm (10\% \text{ of reading} + 5 \text{ words})$	
1G Ω –10G Ω No precision required		1G Ω –10G Ω No precision required	

	Current measurement accuracy	$\pm (1.5\% \text{ of reading} + 5 \text{ words})$	$\pm (1.5\% \text{ of reading} + 5 \text{ words})$
Arc Detect	Measuring range	AC 1mA–20mA	DC 1 μ A–20mA
Comparators			
Judgment method		Window comparison	
		I down ON: When I down < I, PASS; when $I_X \leq I$ or $I_X \geq I$, FAIL (<I under condition I)	
		I down OFF: when $I_X < I$, I pass, when $I_X \geq I$, FAIL, insulation resistance judgment method is the same as above.	
Current cap setting I	AC	0.001mA–20mA	0.001mA–10mA
	DC	0.1 μ A–10mA	0.1 μ A–10mA
Current upper limit setting I (LOWER OFF)	AC	0.001mA–20mA	0.001mA–10mA
		0.1 μ A–10mA	0.1 μ A–10mA
Resistance upper limit setting	OFF–0.1M Ω –10G Ω		OFF–0.2M Ω –10G Ω
Resistance lower limit setting	0.1M Ω –10G Ω		0.2M Ω –10G Ω

Discrimination output	PASS / FAIL LCD and LED display separately, audible alarm
Parameter setting	
Voltage rise time	0.1s–999.9s
Voltage drop time	0s–999.9s (only after withstand voltage PASS)
Voltage waiting time	0.3s–999.9s (only DC withstand voltage, and meets the rise time + test time > waiting time)
Test time setting	0.3s–999.9s (at TIMER ON time)
Time accuracy	$\pm (0.2\% \text{ of setting value} \pm 0.1s)$

6.2. General technical indicators

General technical indicators			
Working temperature and humidity		0°C–40°C, ≅75%RH	
power supply	100V-121V, 198V-242V, 47.5-63Hz		
Power consumption	RK9920/A/B	≅ 300VA	RK9910/A/B ≅ 200VA
Shape volume	430mm×110mm×350mm		
weight	15KG		14KG

7. Instrument System Upgrade Steps:

1. Connect the USB device to the computer, the computer resource manager displays the USB disk, copies the upgrade file to the root directory, and restarts the device to complete the upgrade. If there is an error in the upgrade, please contact us in time.
2. Press and hold STOP+STAR to restart the power supply, clear the data error caused by version change, and restore the set data to the default

factory data.

8 .Appendix: Parameter Table

Parameter / model		Program-controlled insulation withstand voltage tester		Programmable withstand voltage tester			
		RK9920	RK9910	RK9920A	RK9910A	RK9920	RK9910B
Withstand voltage test	Output voltage (KV)	AC:0.05-5.00 DC:0.05-6.00		AC:0.05-5.00 DC:0.05-6.00		AC:0.05-5.00	
	Test accuracy	± (2.0% setting + 2V)					
	Output accuracy	± (2.0% setting + 5V) No load					
	Test current (MA)	AC:0.001 mA-20mA DC:0.1uA-10mA	AC:0.001 mA-10mA DC:0.1uA-5mA	AC:0.001 mA-20mA DC:0.1uA-10mA	AC:0.001 mA-10mA DC:0.1uA-5mA	AC:0.001 mA-20mA DC:0.1uA-5mA	AC:0.001 mA-10mA DC:0.1uA-5mA
Test accuracy	± (2.0% of reading + 5 words)						
Insulation test	The output voltage (KV)	0.05KV-5.000KV ± (1.0% of reading)		/	/	/	/
	Test accuracy	±(2.0% setting + 2V)		/	/	/	/
	Test resistance	0.1MΩ-100GΩ	0.2MΩ-100GΩ	/	/	/	/

e							
Test accuracy	$\geq 500 \text{ V}$	$\geq 500 \text{ V}$	/	/	/	/	
	$0.10 \text{ M}\Omega$ $-1.0\text{G} \pm 5\%$ $1.0\text{G}-50.0\text{G} \Omega \pm 10\%$ $50.0\text{G}-100.0\text{G} \Omega \pm 15\%$	$0.20 \text{ M}\Omega$ $-1.0\text{G} \pm 5\%$ $1.0\text{G}-50.0\text{G} \Omega \pm 10\%$ $50.0\text{G}-100.0\text{G} \Omega \pm 15\%$					
Discharge function	$> 500 \text{ V}$	$> 500 \text{ V}$	/	/	/	/	
	$0.10 \text{ M}\Omega$ $-1.0\text{G} \pm 10\%$ $1.0\text{G}-10.0\text{G} \Omega$	$0.20 \text{ M}\Omega$ $-1.0\text{G} \pm 10\%$ $1.0\text{G}-10.0\text{G} \Omega$					
Arc detection							
Measuring range	Corresponding current	1mA-20mA					
testing time		0.1S-999.9S					
Output frequency		50Hz/60Hz					
Input characteristics		115V/230V $\pm 10\%$ 50Hz/60Hz					
Test alarm		Buzzer, LCD, FAIL indicator					
Keyboard lock		Independent keyboard lock key					
screen size		5 inch TFT LCD					
Communication Interface		HANDLER, RS232, RS485, USBDEV (computer interface), USBHOST (U disk interface)					
Voltage rise time		0.1S-999.9S					
Test time setting (AC / DC)		0.2S-999.9S					
Voltage drop time		0.1S-999.9S					
waiting time		0.2S-999.9S					
Memory size (W×H×D)		16M Flash, 50 test steps per file 430mm×105mm×350mm					

weight	15kg	14kg	15kg	14kg	15kg	14kg
Accessories	Test lead, ground lead, power lead					

9. Overview and Parameters of RK99 Series Programmed Medical withstand voltage tester

Rk99 series program-controlled medical withstand voltage tester has all the functions of conventional withstand voltage tester, and the function of arc (flash-over) detection is added. Through the external oscilloscope, the phenomenon of "Flash-over" of the tested electrical equipment can be detected intuitively, accurately, quickly and reliably. When there is no "Flash-over" phenomenon in the tested electrical equipment, the oscilloscope displays a stable "Lishayu figure, i.e. a closed circle" Ring ", if the "Flash-over" phenomenon occurs to the electrical equipment under test, the "Flash-over" phenomenon will occur to the large electrical equipment in the edge green of Lishayu figure to ensure the safety of the electrical equipment under test. At the same time, this product is also suitable for detecting various electrical equipment with "Flash-over" defects. It is an indispensable pressure tester for medical electrical equipment manufacturers, maintenance departments, users, product quality inspection departments and technical supervision departments.

Conform to the medical standard of GB9706.-2007 (EC60601-1:1988)

Application Area

Medical devices: all kinds of new medical instruments and medical supporting instruments, heart monitoring, medical imaging, biochemical analysis instruments, sphygmomanometers, thermometers and other home-based medical devices.

Diagnosis and treatment equipment: X-ray diagnosis and inspection equipment, ultrasound diagnosis, nuclear medicine, endoscope system, treatment equipment of facial features department, dynamic analysis and treatment equipment, cryopreservation equipment, dialysis treatment equipment, first aid equipment, ward nursing equipment and instruments: all kinds of beds, cabinets, operating chairs, beds and other auxiliary equipment: medical nursing data and image processing equipment, rehabilitation equipment, special equipment for the disabled, etc.

Dental medical equipment: dental diagnostic medical equipment, dental

surgical equipment, dental technician equipment, medical MRI equipment

Performance characteristics

☐ AC/DC withstand voltage function adopts DDS digital signal synthesis technology to generate accurate, stable, pure and low distortion wave-forms

☐ Adjustable high-voltage rise and fall times to meet the requirements of different test objects. Test results with arc detection function can be stored synchronously.

☐ It has dual-frequency comprehensive test, humanized operation interface with frequency range of 50Hz and 60Hz, support for digital key input, dial pull input, and simpler operation

☐ Complete operation help tips can effectively improve user efficiency and support character file name input. The maximum length of file name is 12 characters

☐ Test steps and system status information are displayed synchronously, which is convenient to know the detailed information of test steps and system status information during testing.

☐ Chinese-English bilingual operation interface supports large-capacity storage to meet the needs of different users and oscilloscope interface to

meet the requirements of different test applications

☐ It can monitor the arcing and flash-over phenomenon of the tested object

☐ GB 9701-2007 (EC 60601-1: 1988) Test Voltage Requirement: Flash-over or breakdown shall not occur during the test.

☐ Medical withstand voltage tester has specially added an oscilloscope interface to observe flash-over and arcing phenomena through Lishayu graphs.

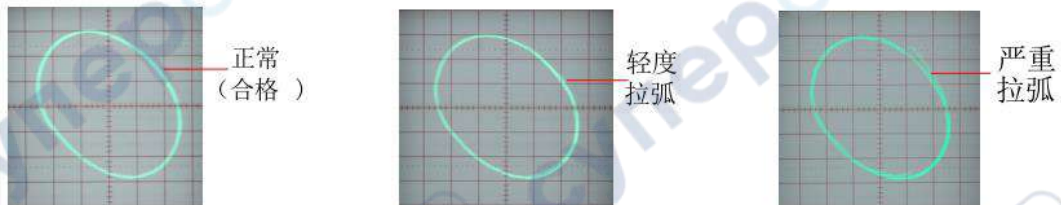

Attached table: parameter table

Parameter / model		Program-controlled insulation withstand voltage tester		Programmable withstand voltage tester			
		RK9920	RK9910	RK9920A	RK9910A	RK9920	RK9910B
Withstand voltage test	Output voltage (KV)	AC:0.05-5.00 DC:0.05-6.00		AC:0.05-5.00 DC:0.05-6.00		AC:0.05-5.00	
	Test accuracy	± (2.0% setting + 2V)					
	Output accuracy	± (2.0% setting + 5V) No load					
	Test current	AC:0.001 mA-20mA	AC:0.001 mA-10mA	AC:0.001 mA-20mA	AC:0.001 mA-10mA	AC:0.001 mA-20mA	AC:0.001 mA-10mA

	(MA)	DC:0.1uA -10mA	DC:0.1uA -5mA	DC:0.1uA -10mA	DC:0.1uA -5mA		
	Test accuracy	± (2.0% of reading + 5 words)					
Insulation test	The output voltage (KV)	0.05KV-5.000KV ± (1.0% of reading)		/	/	/	/
	Test accuracy	±(2.0% setting + 2V)		/	/	/	/
	Test resistance	0.1MΩ-100GΩ	0.2MΩ-100GΩ	/	/	/	/
	Test accuracy	≥ 500 V 0.10 M Ω -1.0G ± 5%	≥ 500 V 0.20 M Ω -1.0G ± 5%	/	/	/	/
		1.0G-50.0G Ω ± 10% 50.0G-100.0G Ω ± 15 words	1.0G-50.0G Ω ± 10% 50.0G-100.0G Ω ± 15 words	/	/	/	/
	> 500 V 0.10 M Ω -1.0G ± 10% 1.0G-10.0G Ω	> 500 V 0.20 M Ω -1.0G ± 10% 1.0G-10.0G Ω					
	Discharge function	Automatic discharge after test		/	/	/	/
Arc detection							
Measuring	Corresponding current	1mA-20mA					

range						
testing time	0.1S-999.9S					
Output frequency	50Hz/60Hz					
Input characteristics	115V/230V±10% 50Hz/60Hz					
Test alarm	Buzzer, LCD, FAIL indicator					
Keyboard lock	Independent keyboard lock key					
screen size	5 inch TFT LCD					
Communication Interface	HANDLER, RS232, RS485, USBDEV (computer interface), USBHOST (U disk interface)					
Voltage rise time	0.1S-999.9S					
Test time setting (AC / DC)	0.2S-999.9S					
Voltage drop time	0.1S-999.9S					
waiting time	0.2S-999.9S					
Memory size (W×H×D)	16M Flash, 50 test steps per file 430mm×105mm×350mm					
weight	15kg	14kg	15kg	14kg	15kg	14kg
Accessories	Test lead, ground lead, power lead					

10 、 Attached accessories

RK26003A withstand voltage test clip * 1

RK26003B withstand voltage grounding clamp * 1

RK-8G-1 Cross uncontrolled high voltage probe * 1

Power cord 1.8m * 1

BNC line double-headed line * 2 (RK99 program-controlled medical pressure withstand instrument series)

Manual * 1

Chapter 7 Description of multi-channel voltage-resistant insulation resistance tester

7.1 Description of the multi-channel module

The multichannel output is a built-in high-voltage transfer module attached to the lower part of the instrument. Through the multi-channel output module, multiple points to be tested of the element can be connected with multiple channels of the instrument once. During the test, the instrument controls the channel switch according to the user setting, and connects the corresponding port to the voltage resistance test end to realize the controllable test. The characteristic of this test is that customers can achieve rapid connection through the test fixture, the test process does not need to switch the interface, make the test safe and reliable.

The test connection is indicated as follows:

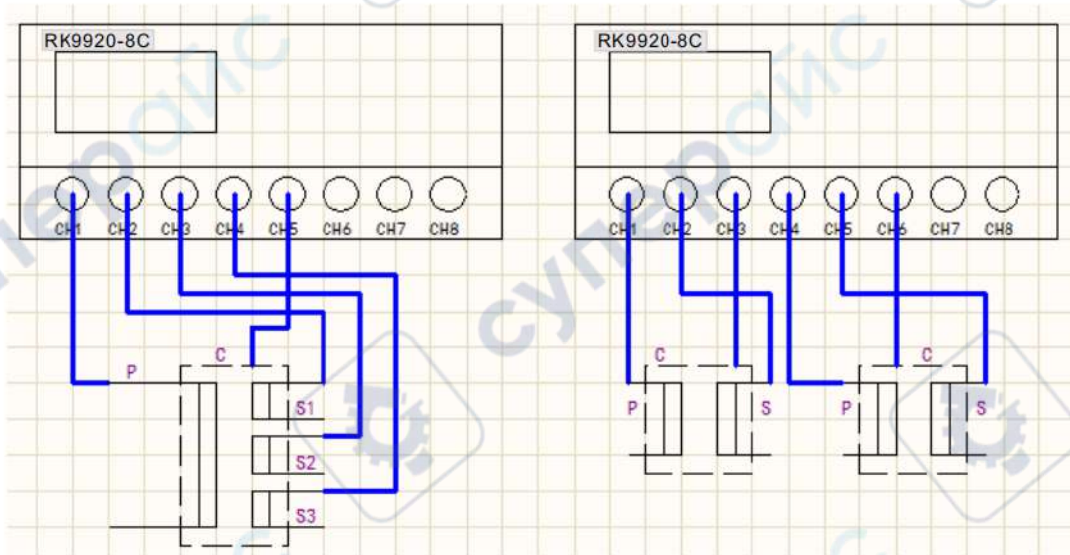

Multi-channel function

RK9920-4C / 8C is added to RK9920 with 4 / 8 program scanning channels. With suitable test tools, it can realize the rapid program control connection of components, and greatly accelerate the test speed of multi-parameter measurement.

7.2 The SCAN Multichannel Setup Step

1. Start the RK9920-8C instrument and enter the main interface, as shown below:



2. Press the soft key of the instrument panel to enter the parameter setting interface as shown below:



3. Press the panel soft key F5-the next page, and enter the multi next page, as shown below:



4. Press the panel soft key F3-channel setting and enter the multi-channel setting interface, as shown below:



扫描	SCAN:	1 2 3 4 5 6 7 8	可控输出通道8路
		白色	该路为开路状态
		红色	该路接高压端
		绿色	该路接测试端

5. Set up application examples, as shown below:



Set channels 1,2 and 3 as high end, 4,5 and 6 as low end, and 7 and 8 as open circuit state. High-end channel state becomes red, low-end channel state becomes green, and open-circuit state becomes white. At the same time, the channel status bar at the bottom of the display also becomes the set channel state.

6. Press the F4-return key or the panel TEST key to enter the test interface for testing.

7. The new step mode selection function has the following three states: F1 F2 F3 F4 F5

7.1 Normal mode (NORMAL): After the test starts, start from step one. If other conditions allow, finish the last step and end the test.

7.2 Cycle Mode (REPPEAT): After the test is started, the test starts from the step beginning. If other conditions allow, the last step will automatically return to the first step for the cycle test.

7.3 Single Step mode (STEP): After the test interface switches to a certain step, start the test. The instrument will only perform the test item of the current step and stop the test after the test is finished.

7.4 Specific operation steps are as follows:

7.4.1 Press the F3 key or the system setting key on the panel at the main test interface, as shown below:



7.4.2 Press F3 key (system setting) to enter the system setting interface, as shown below:



7.4.3 After entering the system setting interface, press F5 key (next page) to enter the next interface of the system setting interface, as shown below:



7.4.4 Display the step mode after entering the next interface of the system setting, as shown below:



7.4.5 The selection of the step mode can be completed by rotating the encoding knob on the panel, selecting the desired mode and pressing the encoding knob.

7.3 Parameter table of Rk9920 series multi-channel voltage-resistant insulation resistance tester

model		RK9920-4C	RK9920-8C	RK9920A-8 C	RK9920A-4 C
Scan interface		4 Road	8 Road	8 Road	4 Road
high-voltage insulation test					
output voltage	AC	0.05kV-5.00kV $\pm 2\%$			
	DC	0.05kV-6.00kV $\pm 2\%$			
Range of current test	AC	0 — 20mA $\pm(2\%$ readings + 5 words)			
	DC	0 — 10mA $\pm(2\%$ readings + 5 words)			
	Fast discharge	Automatic Discharge after the test (DCW)			
insulation resistance test					
Output voltage (DC)		0.05kV-5.00kV $\pm (1\% + 5 \text{ words})$			
Range of resistance test		0.1M Ω -10G Ω			
Resistor test accuracy		$\geq 500V$ 0.1M Ω -1G Ω $\pm 5\%$ Read + 5 words 1G Ω -10G Ω $\pm 10\%$ Read + 5 words 1G Ω -500G Ω $\pm (10\% + 5 \text{ words})$ 50.0G Ω -100G Ω $\pm 15\%$ $< 500V$ 0.1M Ω -1G Ω $\pm 10\%$ Read + 5 words 1G Ω -10G Ω No accuracy requirements are available for reference only	/		
Discharge function		Automatic discharge after the test			
Arc detection					
measuring range	AC/DC	Level 1~9			
General parameters					
Voltage up time		0.1S~999.9S			
Test time setting		0.2S~999.9S			
Voltage drop time		0.1S~999.9S			
wait time (IR)		0.2S~999.9S			
Time accuracy		$\pm (1\%+0.1S)$			
interface		Handler、RS232、RS485、USB DEVICE、USB HOST			
Operating temperature and humidity		10°C~40°C $\leq 90\%$ RH			
power requirement		90~121V AC (60Hz) or 198~242V AC (50Hz)			

power dissipation	<400VA			
standard configuration	RK00001 power cable, RS232 communication cable RK00002, RS232 turn USB line RK00003, USB switch line, RK8N + high voltage bar cable RK00006, 16G U disk (manual), RK26003A tester, RK26003B test line			
Optional	RK00031 USB to RS485 female serial port line industrial grade connecting line is 1.5 meters long			
Weight (net weight)	19.35KG	19.75KG	19.35KG	19.75KG
size (HxDxL)	174mm×450mm×352mm			

RK9920-16C、RK9920-32C

model	RK9920-16C		RK9920-32C	
Scan the interface	16 Road		32Road	
high-voltage test				
output voltage	AC	0.05kV ~ 5.00kV		±2%
	DC	0.05kV ~ 6.00kV		±2%
Range of current test	AC	0 ~ 20mA ±(2%Reading number + 5 words)		
	DC	0 ~ 10mA ±(2%Reading number + 5 words)		
	Fast discharge	Automatic discharge after the test (DCW)		
insulation resistance test				
output voltage (DC)	0.05kV ~ 5.0kV ±(1%+5 words)			
Resistor test range	0.1MΩ-100.0GΩ			
Resistor test accuracy	≥500v 0.10MΩ-1.0GΩ ±5% 1.0G-50.0 GΩ ±10% 50.0 GΩ-100.0 GΩ±15% <500V 0.10MΩ-1.0GΩ ±10% 1.0GΩ-10.0GΩ No precision requirements			
Discharge function	Automatic discharge after the test			
Arc detection				
measuring range	AC	1 ~ 20mA		
	DC	1 ~ 20mA		
General parameters				

Voltage up time	0.1 ~ 999.9S
Test time setting (AC/DC)	0.2 ~ 999.9S
Voltage drop time	0.1 ~ 999.9S
wait time (IR)	0.2 ~ 999.9S
Time accuracy	±1%+0.1S
interface	HANDLER interface, RS232C interface, RS485 interface, USB interface, U disk interface
working temperature	10°C ~ 40°C, ≤90%RH
power requirement	90 ~ 121V AC(60Hz)或 198 ~ 242V AC (50Hz)
power dissipation	< 400VA
volume(D×H×W)	500mm×1300mm×550mm
Weight (net weight)	78.18KG
Optional attachment	RK00031 USB to RS485 female serial port line industrial class connecting line 1.5 meters long, upper machine
Random standard accessories	Power cable RK00001, RS232 communication cable RK00002, RS232 transfer USB cable RK00003, USB transfer port cable RK00006, 16G U disk (manual), wire interface transfer drive disc, RK26003A test line, RK26003B test line, RK8N + high voltage bar

7.4 Channel test diagram

高压扫描器8通道测试图

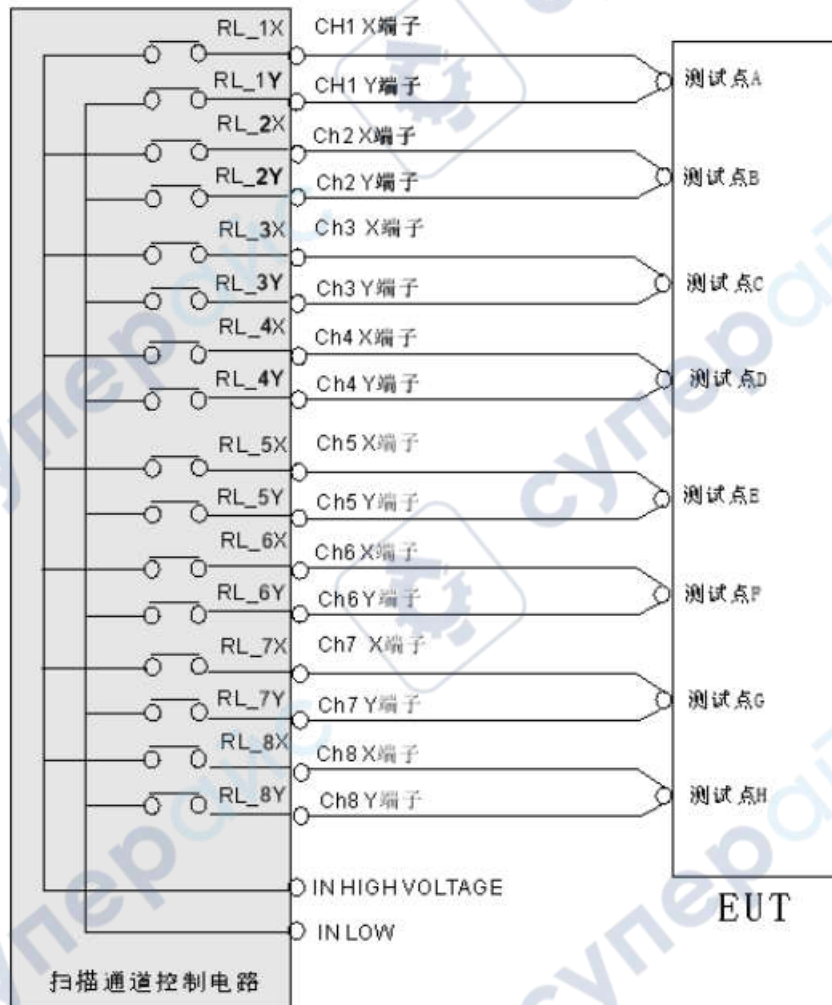

7.5 Multi-channel SCPI serial port communication instruction

FUNC:SOURce:STEP#:MODE:AC:CH#:STATE

Set / query the status of high-end, low-end or open channel

in AC mode

--form

Format: FUNC: SOURce: STEP #: MODE: AC: CH #: STATE <Status value>

FUNC:SOURce:STEP#:MODE:AC:TEAM#:CHALL<8 Status values>

Query format: FUNC: SOURce: STEP #: MODE: AC: CH #: STATE?

- -Data <state value>

Data type: the whole type

Data range: 0 / 1 / 2

0: Open circuit 1: High end connection 2: Low end connection

Example: Take the CH2 of AC mode in STEP1 as a high-end connection

Setup command: FUNC: SOURce: STEP1: MODE: AC: CH 2: STATE1

Query command: FUNC: SOURce: STEP1: MODE: AC: CH 2: STATE?

Return value: 1

Set the 8 channels of AC mode group 1 in STEP1 as high-end, low-end, high-end, low-end, high-end, low-end, high-end, low-end,"

Set command:

FUNC:SOURce:STEP1:MODE:AC:TEAM 1:CHALL1, 2, 1, 2, 1, 2, 1, 2

FUNC:SOURce:STEP#:MODE: DC :CH#:STATE

Set / query the status of high-end, low-end or open channel in DC mode.

--form

Format: FUNC: SOURce: STEP #: MODE: DC: CH #: STATE <Status value>

FUNC:SOURce:STEP#:MODE: DC:TEAM#:CHALL<8 Status values>

Query format: FUNC: SOURce: STEP #: MODE: DC: CH #: STATE?

- -Data <state value>

Data type: the whole type

Data range: 0 / 1 / 2

0: Open circuit 1: High end connection 2: Low end connection

Example: Take the CH2 of DC mode in STEP1 as a high-end connection

Setup command: FUNC: SOURce: STEP1: MODE: DC: CH2: STATE1

Query command: FUNC: SOURce: STEP1: MODE: DC: CH2: STATE?

Return value: 1

Set the 8 channels of DC mode group 1 in STEP1 as high-end, low-end, high-end, low-end, high-end, low-end, high-end and low-end

Set command:

FUNC:SOURce:STEP1:MODE: DC:TEAM 1:CHALL1, 2, 1, 2, 1, 2, 1, 2

FUNC:SOURce:STEP#:MODE: IR:CH#:STATE

Set / query the status of high end, low end, or open channel in IR mode.

--form

Format: FUNC: SOURce: STEP #: MODE: IR: CH #: STATE <Status value>

FUNC:SOURce:STEP#:MODE: IR:TEAM#:CHALL<8 Status values>

Query format: FUNC: SOURce: STEP #: MODE: IR: CH #: STATE?

- -Data <state value>

Data type: the whole type

Data range: 0 / 1 / 2

0: Open circuit 1: High end connection 2: Low end connection

Example: Make the CH2 in IR mode in STEP1 a high-end connection

Setup command: FUNC: SOURce: STEP1: MODE: IR: CH2: STATE1

Query command: FUNC: SOURce: STEP1: MODE: IR: CH2: STATE?

Return value: 1

Set the 8 channels of IR mode group 1 in STEP1 as high-end, low-end, high-end, low-end, high-end, low-end, high-end and low-end

Set command:

FUNC:SOURce:STEP1:MODE: IR:TEAM 1:CHALL1, 2, 1, 2, 1, 2, 1, 2

7.6 Backing list

名称	规格型号	单位	数量
耐压绝缘电阻测试仪	RK9920-8C	台	1
说明书	U 盘	个	1
校准报告	/	份	1
电源线	RK00001	根	1
合格证	/	份	1
高压测试线	RK26003A	付	9
测试线	RK26003B	付	1
高压棒	RK8N+	条	1
RS232 电缆	RK00002	条	1
RS232 转 USB 线	RK00003	条	1
USB 转方口线	RK00006	条	1
RS232 转 USB 驱动光碟	光碟	张	1

检验员: _____

日期: _____

Chapter 8: RK9914A Series Technical Parameters

8.1 Parameter

Parameter model		RK9914A	RK9914B	RK9914C
ACW	Output voltage range	(0.00~5.00)kV		
	maximum(power)output	500VA(5.0kV 100mA)		250VA(5.0kV 50mA)
	Maximum rated current	100mA		50mA
	discharge waveform	Sine-wave DDS + power amplifier		
DCW	Output voltage range	(0.00~6.00)kV	/	(0.00~6.00)kV
	maximum(power)output	300VA(6.0kV 50mA)	/	150VA(6.0kV 25mA)
voltmeter	range	AC (0.00~ 5.00)kV DC(0.00~ 6.00)kV	AC (0.00~ 5.00)kV	AC (0.00~ 5.00)kV DC(0.00~ 6.00)kV
	accuracy	± (1% + 2 words)		
	Setting error	± (1% + 2 words)		
ammeter	measuring range	AC 0~100mA; DC: 0~50mA	AC 0~ 100mA	AC 0~50mA; DC: 0~ 25mA
	measurement accuracy	± (1% + 2 words)		
time-meter	range	0.0-999.9S		
	minimum resolution	0.1S		
	testing time	0.1S-999S OFF=continuous test		
	Arc detection	0-20mA		
	output frequency	50Hz/60Hz		
	working temperature	0-40°C ≤75%RH		
	power requirement	110/220±10% 50Hz/60Hz±3Hz		
	interface	Standard with RS232, RS485, USB, PLC, optional LAN		
	screen	7 inch TFT 800*480		
	Appearance volume(DxHxW)	570mm×155mm×440mm		
	weight	30.2KG		
	Random standard accessories	Power cable RK00001, RS232 communication cable RK00002, RS232 turn to USB line RK00003, USB turn square port connector RK00006, 16G U disk (manual), wire interface transfer drive disc, RK26003A test line, RK26003B test line, RK8N + high voltage bar		
	Select accessories	RK00031 USB to RS485 mother serial port line industrial grade connecting line 1.5 meters long, upper machine		

8.2 Accessories

Model	Type	Summary
RK8N+	Standard Configuration	The Instrument Is Equipped With Uncontrolled High Pressure Rod As Standard, Which Can Be Purchased Separately.
RK00002	Standard Configuration	The Instrument Is Equipped With Test Line As Standard, Which Can Be Purchased Separately.
RK00003	Standard Configuration	The Instrument Is Equipped With Test Line As Standard, Which Can Be Purchased Separately.
RK00004	Standard Configuration	BNC Line Is Provided As Standard And Can Be Purchased Separately.
RK20	Standard Configuration	The Instrument Is Equipped With DB9 As Standard, Which Can Be Purchased Separately.
RK00001	Standard Configuration	The Instrument Is Equipped With American Standard Power Cord, Which Can Be Purchased Separately.
Certificate And Warranty Card	Standard Configuration	The Instrument Is Equipped With Standard Certificate And Warranty Card.
Factory Calibration Certificate	Standard Configuration	Calibration Certificate Of Standard Equipment.
Instructions	Standard Configuration	The Instrument Is Equipped With Standard Product Instructions.
PC software	Optional	The instrument is equipped with 16G U disk (including upper computer software).
RS232 to USB cable	Optional	The instrument is equipped with RS232 to USB cable (upper computer).
USB to square port cable	Optional	The instrument is equipped with USB square port connecting cable (upper computer).

Chapter 9: RK9974 Series Technical Parameters

9.1 Parameter

Parameter	models	RK9974-10	RK9974-20	RK9974-30	RK9974-50
ACW	Output voltage range	(0.10 ~ 10.00)kV	(0.50 ~ 20.00)kV	(1.00 ~ 30.00)kV	(1.00 ~ 50.00)kV
	maximum(power)output	200VA(10.0kV 20mA)	400VA(20.0kV 20mA)	600VA(30.0kV 20mA)	1000VA(50.0kV 20mA)
	Maximum rated current	20mA			
	discharge waveform	Sine-wave DDS + power amplifier			
DCW	Output voltage range	(0.10 ~ 10.00)kV	(0.10 ~ 20.00)kV	/	
	maximum(power)output	100VA(10.0kV 10mA)	200VA(20.0kV 10mA)		
	Maximum rated current	10mA			
voltmeter	range	AC (0.10 ~ 10.00)kV	AC (0.10 ~ 20.00)kV	AC (0.00 ~ 30.00)kV	AC (0.00 ~ 50.00)kV
	accuracy specification error	± (1% + 3 words)		± (2% + 5 words)	
ammeter	measuring range	AC 0 ~ 20mA			
	measurement accuracy	± (1% + 3 words)			± (2% + 5 words)
time-meter	range	0, 0.999.9S OFF=continuation			
	minimum resolution	0.1S			
testing time	0.0S-999S OFF=continuous test				
Arc detection	0-20mA				
output frequency	50Hz/60Hz				
working temperature	0-40°C ≤75%RH				
power requirement	110/220±10% 50Hz/60Hz±3Hz				
interface	Standard with RS2	Standard equip	Standard equip	Standard equip	Standard equip

	32, RS485, USB, PLC, optional LAN	Equipped with RS232, RS485, USB, PLC, wireless remote control, optional LAN	Equipped with RS232, RS485, USB, PLC, wireless remote control, optional LAN	Equipped with RS232, RS485, USB, PLC, wireless remote control, optional LAN
Wireless remote control function	no		yes	
screen	7 Inch TFT 800*480			
Appearance volume (D×H×W)	570×155×440 mm	440×135×485 mm	440×135×485 mm	440×135×485 mm
weight	About 30.2KG	About 78KG	About 80KG	About 85KG
Random standard accessories	Power cable RK00001, RS232 communication cable RK00002, RS232 turn USB cable RK00003, USB turn square port cable RK00006, 16G U disk (manual), wire interface transfer drive disc, RK26003A test line, RK26003B test line, RK8N + high voltage bar			
Choose accessories	RK00031 USB to RS485 mother serial port line industrial class connecting line 1.5 meters long, upper machine			

9.2 Accessories

Model	Type	Summary
RK8N+	Standard Configuration	The Instrument Is Equipped With Uncontrolled High Pressure Rod As Standard, Which Can Be Purchased Separately.
RK00002	Standard Configuration	The Instrument Is Equipped With Test Line As Standard, Which Can Be Purchased Separately.
RK00003	Standard Configuration	The Instrument Is Equipped With Test Line As Standard, Which Can Be Purchased Separately.
RK00004	Standard Configuration	BNC Line Is Provided As Standard And Can Be Purchased Separately.
RK20	Standard Configuration	The Instrument Is Equipped With DB9 As Standard, Which Can Be Purchased Separately.
RK00001	Standard Configuration	The Instrument Is Equipped With American Standard Power Cord, Which Can Be Purchased Separately.
Certificate And Warranty Card	Standard Configuration	The Instrument Is Equipped With Standard Certificate And Warranty Card.

Factory Calibration Certificate	Standard Configuration	Calibration Certificate Of Standard Equipment.
Instructions	Standard Configuration	The Instrument Is Equipped With Standard Product Instructions.
PC software	Optional	The instrument is equipped with 16g U disk (including upper computer software).
RS232 to USB cable	Optional	The instrument is equipped with RS232 to USB cable (upper computer).
USB to square port cable	Optional	The instrument is equipped with USB square port connecting cable (upper computer).
RK00031	Optional	The instrument is optional with USB to 485, and the connecting line is 1.5 meters long and can be purchased separately.