

PDM1529S/PDM5219S INSULATION RESISTANCE TESTER

INSTRUCTION MANUAL

SANWA ELECTRIC INSTRUMENT CO., LTD.

Dempa Bldg., 4-4 Sotokanda 2-Chome
Chiyoda-ku, Tokyo 101-0021, Japan



[1] Read First: Safety Information

We thank you for your purchasing our product, the battery-driven insulation resistance tester.

This is a DC resistance tester developed under the principle to provide new and unique design and function for the measurement of insulation resistance of each kind of electric equipments. Since this tester generates high voltage, we recommend that you read this instruction manual thoroughly, and treat the tester correctly and safely. The symbols used on this tester and in this instruction manual denote the following meanings:

- ⚠ Be careful as the high voltage is impressed.
- ⚠ Be careful because there is a possibility of bodily injury or the destruction of equipment.

⚠ WARNING

To ensure that the meter is used safely, follow all safety and operating instructions.

1. Never use tester for high power or high voltage circuit.
2. Pay special attention when measuring the voltage of AC 33 Vrms (46.7 V Peak) or DC 70 V or more to avoid injury.
3. Disconnect power source of the measured circuit before measuring insulation resistance.
4. High voltage is generated while measuring insulation resistance. Be cautions of electric shock.
5. After measuring insulation to avoid electric shock. Be sure to discharge the high voltage charged.
6. Never apply an input signal exceeding the maximum rating input value.
7. Never use tester for measuring the line connected with equipment (i.e. motors) that generates induced or surge voltage since it may exceed the maximum allowable voltage.
8. Never use tester if the tester or test leads are damaged or broken.
9. Never use uncased tester.
10. Always keep your fingers behind the Barriers on the probe when making measurements.
11. Be sure to disconnect the test pin from the circuit when changing the function.
12. Never use tester with wet hands or in a damp environment.

- 1 -

13. Use test leads matching the measurement category of the object measured. If the measurement categories of the instrument and test leads were different, the lowest measurement category would be applied.
14. When handling equipment containing a hazardous live part, be sure to wear insulative protection gear to prevent accidents. Also be sure to observe your local and national safety regulations.
15. Do not attempt any alterations of original specifications.
16. To ensure safety and maintain accuracy, calibrate and check the tester at least once a year.
17. Indoor use.
18. Do not use the instrument in a place where corrosive or explosive gas is produced.
19. To prevent the protection function of the tester from being spoiled, do not use it in a method other than specified.

⚠ CAUTION

Remove components such as semi-conductors and apparatuses from the circuit of measuring object to avoid damages when withstand of the object is unknown or lower than rated measuring voltage of a resistance insulation tester, especially in case of the objects you measure connected with PCs or computers.

Maximum Overload Protection Input

Function (Range)	Maximum rating input value	Maximum overload protection input
ACV (600)	AC 600 V	AC 720 V
DCV (60)	DC 60 V	DC 120 V

[2] Applications and Features

- 2.1 Applications
 - DC insulation resistance tester to measure the insulation resistance of electric lines and electric equipment.
- 2.2 Features
 - This tester has the minimum number of scale graduations and employs a three-range system for easy viewing and readability.
 - The measured voltage is maintained until the low insulation resistance value at the rated current specified in IEC61557-2.

- 2 -

[3] Front View and Name of Each Part

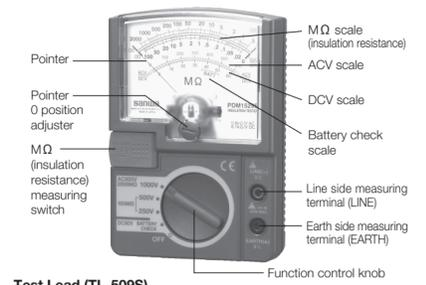

Test Lead (TL-509S)

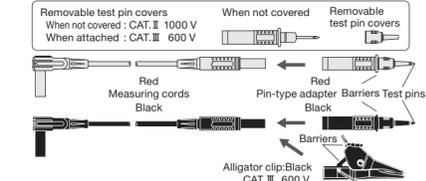

[4] Cleaning and storage

⚠ CAUTION

- The panel and the case are not resistant to volatile solvent and must be cleaned with thinner or alcohol. For cleaning, use dry, soft cloth and wipe it lightly.
- The panel and the case are not resistant to heat. Do not place the instrument near heat-generating devices (such as a soldering iron).
- Do not store the instrument in a place where it may be subjected to vibration or from where it may fall.

- 3 -

- For storing the instrument, avoid hot, cold or humid places or places under direct sunlight or where condensation is anticipated. (See 9.1 Storage temperature/humidity)
- Be sure to remove the battery when the instrument is not to be used for a long period.

[5] Description of Functions

- Function control knob and MΩ (insulation resistance) measuring switch by operating these two switches, the functions and ranges can be set as shown below.

Position of Function Control Knob	MΩ Measuring Switch (*)	Set Range (Function)
AC 600 V	1000 V/2000 MΩ	AC 600 V range
	500 V/100 MΩ	
	250 V/100 MΩ	
AC 600 V	1000 V/2000 MΩ	1000 V/2000 MΩ range
	500 V/100 MΩ	500 V/100 MΩ range
	250 V/100 MΩ	250 V/100 MΩ range
DC 60 V · BATTERY CHECK	OFF	DC 60 V range
	ON	BATTERY CHECK range

- * The MΩ measuring switch is turned on by the following operation.

- ① ON only when the right end of the lever is pressed with a finger. (OFF when the finger is released)
- ② Continuously ON when the left end of the lever is raised. (OFF when it is laid down)

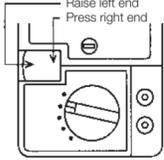

- Meter zero position adjustment
If the meter pointer is not on the ∞ graduation line of the MΩ scale when the function control knob is at OFF, adjust the zero position with a screwdriver.

- 4 -

How To Use Carrying Case

During measurement, set the case as illustrated and hang it from the neck.

- Lid turns in direction at the pivot A.
- Lay it along the bottom of the box and secure it by hooks marked by *

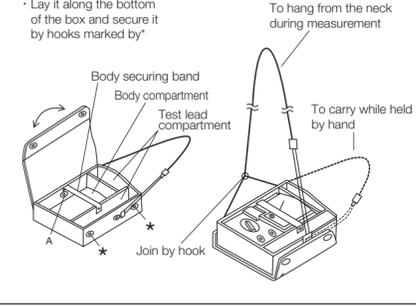

[6] Measuring Method

6.1 Start-up Check

⚠ WARNING

1. Do not use a damaged tester or test lead.
2. Make sure test lead wiring is not broken.
3. When testing the continuity of a test lead, the measuring terminals are under a high voltage. Be careful of electric shock.
4. To prevent electric shock and battery consumption, be sure to turn the MΩ measuring switch and function control knob to OFF after measurement.

- 5 -

Before starting wiring measurement, check the "appearance", "pointer 0 position", "battery" and "measuring lead" in this order. (*The pointer 0 position is the 0 position of the DC 60 V scale or ∞ position of the MΩ scales.)

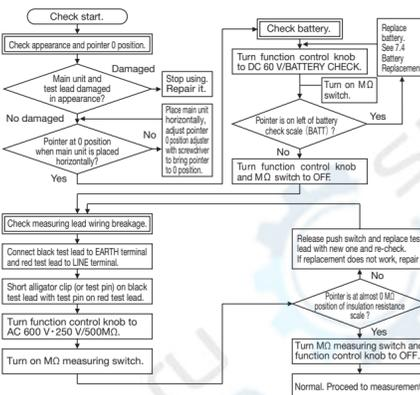

- 6 -

6.2 How to Check the Battery (BATTERY CHECK)

Prior to MΩ (insulation resistance) measurement, be sure to check the battery. A consumed battery will cause not only measurement errors but danger due to erroneous measurement.

For checking methods, refer to 6.1 Start-up Check.

⚠ Do not check the battery for more than 5 seconds.

- 6 -

6.4 Discharge Function

- 1) Reason of a need to discharge
For safety, high voltage remaining in capacitive measuring objects such as capacitors and electric wire must be discharged to prevent accidents.
- 2) Discharging method
This procedure follows the step ⑧ of 6.3-4)
 - ① When the MΩ measurement has been completed, turn off only the MΩ measuring switch with the test pin and the alligator clip connected to the measuring object.
 - ② Then the pointer deflects to the right and its deflection becomes smaller as time passes (indicating the charged charge is being discharged).
 - ③ When the pointer stops at zero (∞ of the MΩ scale) and discharge has been completed, conduct the steps ⑩ and ⑪ of 6.3-4)

6.5 Measurement of ACV (AC voltage) (Measuring range is the AC 600 V range only)

⚠ WARNING

1. Do not apply a voltage exceeding the maximum rated voltage of 600 VAC.
2. During measurement, do not operate the function control knob.
3. Do not measure a voltage with the MΩ measuring switch being pressed or raised.
4. When the circuit to measure has a breaker, measure the voltage on the secondary side (load side).
5. To prevent electric shock, do not touch the metal part of the pin plug and clip.

- 1) Measuring object
Sinusoidal AC voltages (ACV) such as lighting line voltages can be measured.
- 2) Measuring method
 - ① Insert the black measuring cord to which the black alligator clip (or black pin-type adapter) is attached into the EARTH (ground) measuring terminal, and the red measuring cord to which the red pin-type adapter is attached into the LINE measuring terminal.

- 10 -

[9] Specifications

- 9.1 General Specifications
 - AC rectifying method : Half-wave rectification (Mean value indication rms value converted)
 - Model specification : Inner-pole type taut-band system, 48 μA
 - Battery consumption : Checked by BATTERY CHECK range.
 - Allowable temperature/humidity range : 23±5 °C, 75 % RH max., no condensation.
 - Service temperature/humidity : 0~43 °C, 80 % RH max., no condensation.
 - Storage temperature/humidity : -10~50°C, 70 % RH max., no condensation.
 - Service ambient condition : Altitude 2000 m max., environmental pollution II.
 - Power supply : Layer built type alkaline battery 6LR61(6LF22) x1 (9 V)
 - * Factory-preinstalled battery
A battery for monitoring is preinstalled before shipping, therefore it may run down sooner than the battery life specified in the instruction manual. The "battery for monitoring" is a battery to inspect the functions and specifications of the product.
 - Max. power consumption : Approx 2.6 W (at 1000 V/2000 MΩ range)
 - Battery life : When the lower limit measurement resistance value that can maintain the rated output voltage is measured and if one cycle for the measurement is defined as ON for 5 seconds and OFF for 25 seconds, the battery life is 500 cycles.
 - Degree of IP : IP20
 - EMC Directive, RoHS Directive : IEC61326 (EMC), EN50581 (RoHS)
 - Safety : IEC61010-1, IEC61010-2-030 CAT. III 600 V, IEC61010-2-033, IEC61010-031
 - * Measurement Category III : Line from the primary side or branch of equipment (CAT. III) which directly takes in electricity from a distribution board to the receptacle.
 - Year of manufacture : The first two digits of the serial number on the bottom of this product indicate the last two digits of the year.
 - Size and mass : 144 (H) x 99 (W) x 43 (D) mm, approx. 310 g
 - Accessories : Test lead TL-509S, 1 set
Carrying case C-09S, 1 piece
Instruction manual, 1 copy

- 14 -

⚠ REFERENCE

1. The rated current of this tester is 1 mA (1 mA to 1.2 mA).
2. The no-load voltage is within 1.25 times the rated measuring voltage.
3. While measuring there may be an oscillator noise from the meter, but this is not a malfunction.

- 1) Measuring object
Measurement of insulation resistance (MΩ) of electric equipment and circuits.
- 2) Rated measuring voltage

Model	Rated measuring voltage
PDM1529S	250 V/500 V/1000 V
PDM5219S	125 V/250 V/500 V

- 3) Selection of a measuring range
When measuring insulation resistance, select a range of the voltage that is close to the voltage used by the circuit to measure, unless otherwise specified.
For example, when measuring insulation resistance of 100 V home appliances and indoor wiring, select the 125 V rated measuring voltage range and when measuring 200 V power circuits, select the 250 V rated measuring voltage range.

- 4) Measuring method
 - ① Power off the measuring object.
 - ② Insert the black measuring cord to which the black alligator clip (or black pin-type adapter) is attached into the EARTH (ground) measuring terminal, and the red measuring cord to which the red pin-type adapter is attached into the LINE measuring terminal.
 - ③ Turn the function control knob to a desired rated measuring voltage range.
 - ④ Connect the black alligator clip to the object measured. Usually connect the EARTH (ground) measuring terminal to the grounding side.

- 8 -

- ⑤ Connect the tip of the red pin-type adapter to the other side of the object measured.
⚠ CAUTION : If the meter deflects in this state, the measuring object is charged. Be sure to remove the voltage prior to measurement.
- ⑥ Turn on the MΩ measuring switch. (See [5] Description of Functions)
- ⑦ Read the indicated value. Use the appropriate scale according to the position of the function control knob (set range). (See the following fig.)
- ⑧ Turn off the MΩ measuring switch.
- ⑨ Discharge the high voltage charged in the measuring object. (See 6.4 Discharge Function.)
- ⑩ First remove the red test pin from the object measured, and then disconnect the black alligator clip.
- ⑪ Be sure to turn the function control knob to the position of OFF.

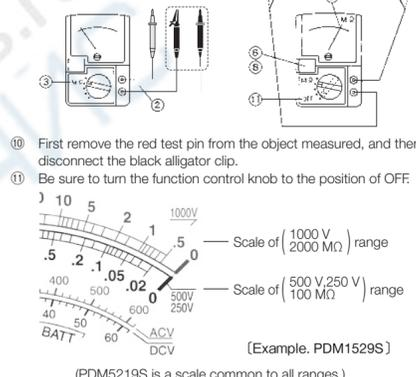

- 9 -

- ② Turn the function control knob to DC 60 V / BATTERY CHECK.
- ③ Connect the black alligator clip to the - side of the object (circuit) measured, and connect the tip of the red pin-type adapter to the + side.
- ④ Read the indicated value on the DCV scale.
- ⑤ First remove the red test pin from the object measured, and then disconnect the black alligator clip from it.
- ⑥ Turn the function control knob to the position of OFF.

[7] Battery Replacement

- ① Remove two battery lid securing screws.
- ② Replace the consumed battery that is connected to the snap terminal with a new one.
- ③ Set the battery in the original place and secure the battery lid with screws.
- ⚠ Be sure to turn the function control knob to the position of OFF prior to replacing the battery.
- ⚠ Be sure to use the alkaline battery 6LR61 (6LF22) x1 (9 V)

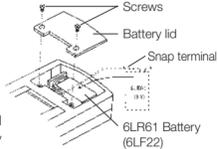

[8] After-Sales Service

- 8.1 Warranty and Provision
Sanwa offers comprehensive warranty services to its end-users and to its product resellers. Under Sanwa's general warranty policy, each instrument is warranted to be free from defects in workmanship or material under normal use for the period of one (1) year from the date of purchase.
This warranty policy is valid within the country of purchase only, and applied only to the product purchased from Sanwa authorized agent or distributor.
Sanwa reserves the right to inspect all warranty claims to determine the extent to which the warranty policy shall apply. This warranty shall not apply to test leads, disposables batteries, or any product or parts, which have been subject to one of the following causes:
1. A failure due to improper handling or use that deviates from the instruction manual.

- 12 -

2. A failure due to inadequate repair or modification by people other than Sanwa service personnel.
3. A failure due to causes not attributable to this product such as fire, flood and other natural disaster.
4. Non-operation due to a discharged battery.
5. A failure or damage due to transportation, relocation or dropping after the purchase.

8.2 Repair

- Customers are asked to provide the following information when requesting services:
1. Customer name, address, and contact information
 2. Description of problem
 3. Description of product configuration
 4. Model Number
 5. Product Serial Number
 6. Proof of Date-of-Purchase
 7. Where you purchased the product
- 1) Prior to requesting repair, please check the following:
Capacity of the battery, polarity of installation and discontinuity of the test leads.
 - 2) Repair during the warranty period:
The failed meter will be repaired in accordance with the conditions stipulated in 8-1 Warranty and Provision.
 - 3) Repair after the warranty period has expired:
In some cases, repair and transportation cost may become higher than the price of the product. Please contact Sanwa authorized agent / service provider in advance.
The minimum retention period of service functional parts is 6 years after the discontinuation of manufacture. This retention period is the repair warranty period. Please note, however, if such functional parts become unavailable for reasons of discontinuation of manufacture, etc., the retention period may become shorter accordingly.
 - 4) Precautions when sending the product to be repaired
To ensure the safety of the product during transportation, place the product in a box that is larger than the product 5 times or more in volume and fill cushion materials fully and then clearly mark "Repair Product Enclosed" on the box surface. The cost of sending and returning the product shall be borne by the customer.

8.3 SANWA web site

http://www.sanwa-meter.co.jp
E-mail: exp_sales@sanwa-meter.co.jp

- 13 -

9.2 Measurement Range and Accuracy

Accuracy assurance : 23±5 °C 75 % RH max.
No condensation
Attitude: Horizontal ±5°. External magnetic field: Not present.
Battery voltage: Within the range in which the battery power is effective.

Model	PDM1529S	PDM5219S
MΩ (Insulation Resistance)	Rated measuring voltage	Rated measuring voltage
	Maximum value	Maximum value
	1000 V	500 V
	2000 MΩ	100 MΩ
Accuracy	1st effective measurement range	1st effective measurement range
	2nd effective measurement range	2nd effective measurement range
	No load voltage	No load voltage
	Rated current	Rated current
ACV	0-600 V	0-60 V
	DCV	0-60 V
Operating instrument uncertainty	MΩ range	MΩ range
	DCV range (50/60 Hz sine wave)	DCV range (50/60 Hz sine wave)

- 15 -