Operation Manual

TH6400 Series

Programmable Triple-channel DC Power Supply

Contents

Chapter 1 Introduction.....	1
1.1 Introduction to Instrument.....	1
1.2 Working Condition.....	1
Chapter 2 Precautions for Usage.....	2
2.1 Dimension and Weight.....	2
2.2 Safety Requirements.....	2
2.3 Electromagnetic Compatibility.....	2
Chapter 3 Introduction to Front and Rear Panels.....	3
3.1 Front panel.....	3
3.2 Rear panel.....	4
3.3 Zone Display.....	4
3.4 Introduction to Page Display.....	5
Chapter 4 Operation.....	6
4.1 Output display.....	6
4.1.1 Value Setting.....	6
4.1.2 Output.....	6
4.2 CH SET.....	7
4.2.1 Voltage and Current Set.....	7
4.2.2 Max. Voltage Set.....	8
4.2.3 OVP Volt Set.....	8
4.2.4 Time Set.....	8
4.2.5 OVP Switch.....	8
4.2.6 Time Function.....	8
4.2.7 Save Value.....	9
4.3 CH File.....	9
4.3.1 Recall and Delete.....	9
4.4 Menu Set.....	9
4.4.1 Language.....	10
4.4.2 Key Voice.....	10

4.4.3 P-Mem	10
4.4.4 R-Wait	10
4.4.5 Bus Mode	11
4.4.6 Baud Rate	11
4.4.7 GPIB-Addr	11
4.4.8 Combine	11
4.4.9 Date	12
Chapter 5 Correct Use of the Instrument.....	12
Chapter 6 Interface and communication.....	13
6.1 Remote Control	13
6.1.1 RS232 Description	13
6.1.1.1 Introduction of RS232 Interface.....	13
6.1.1.2 Communicate with PC.....	14
6.1.2 GPIB Interface.....	15
6.1.2.1 GPIB Bus.....	15
6.1.2.2 GPIB Interface Function.....	17
6.1.2.3 GPIB Address.....	17
6.1.3 USBCDC	17
6.1.3.1 System Configuration.....	17
6.1.3.2 Install the Driver.....	17
6.2 Command Instruction.....	19
6.2.1 Syntax Conventions.....	19
6.2.2 Command Reference	20
6.2.2.1 Supported GPIB Common Command.....	20
6.2.2.2 SCPI Command.....	20
Chapter 7 Specification	27

Declaration

The descriptions contained in this manual may not cover all information about this instrument. Introductions to the improvements of the instrument in performance, function, internal structure, outer appearance, accessories, packing material, etc. are subject to change without notice. If you find any inconformity of this manual with our instruments, please contact us for further consultation by the address listed on the cover.

Chapter 1 Introduction

Thank you for your purchase and use of our products. This chapter will introduce the basic instrument performance, which is followed by notes of unpacking and installing.

1.1 Introduction to Instrument

TH6400 series is a programmable multi-channel linear DC power supply. The series of instruments have powerful functions and superior performance. The use of LCD screen display makes the display clear and menu operation easy, which adapts to the needs of rapid operation on the production site and high precision and stability of high-precision laboratory. Also, being equipped with RS232 interface, USB interface and GPIB interface, they are convenient for the instrument used in remote operation of the computer.

Special features and benefits of the instrument are as follows:

- 480*272 pixels, 24-bit color, 4.3-inch color TFT LCD screen, used to set the test conditions and measurement results display
- Numeric keyboard operation
- High accuracy and high resolution
- Low ripple and low noise
- Intelligent fan control to save energy and reduce noise
- Software control and testing through the computer
- 3 channel programmable voltage and current output
- Fine-tune the value with knobs and cursors
- The maximum timer setting time is 99999.9 seconds

1.2 Working Condition

- **Power Connection**

Power supply: 220V (1±10%)

Power supply frequencies: 50Hz/60Hz (1±5%)

Power range: <50VA

- **Environment Temperature and humidity**

Normal working temperature: 0°C to 40°C Humidity: < 90%RH

Reference working temperature: 20°C ±8°C Humidity: < 80%RH

Transport working temperature: 0°C ~55°C Humidity: ≤93%RH

- **Warm-up**

For accurate measurement, the warm-up time should not be less than 20 minutes.

Chapter 2 Precautions for Usage

- Please do not use the tester in dusty, vibrative, direct sunlight and corrosive gases and other adverse environments.
- When the instrument is not used for a long time, please put it in the original box or similar box and stored in a ventilated room with temperature of 5°C~40°C and relative humidity less than 85% RH. Do not store the tester in a corrosive atmosphere containing harmful impurities and should avoid direct sunlight.
- The instrument has been carefully designed to reduce clutter due to AC power input. However, it should still be used under low noise conditions. If that is inevitable, please install the power filter.
- There is cooling fan on the rear panel and cooling vents in the left and right case to avoid influencing the accuracy due to internal temperature rise. Please make sure the instrument is in good ventilation.
- Do not switch the instrument frequently to avoid loss of stored data.

2.1 Dimension and Weight

- **Dimension (W*H*D):** 218mm*88.8mm*473mm
- **Weight:** 12kg

2.2 Safety Requirements

This tester is a Class I safe equipment.

- **Insulation resistance**
In the reference working conditions, the insulation resistance between the power terminals and the shell is not less than 50MΩ.
In hot and humid transport conditions, the insulation resistance between the power terminals and the shell is not less than 2MΩ.
- **Dielectric strength**
In the reference working conditions, the power terminal and the shell can withstand for one minute with no breakdown and flashover phenomenon of 1.5kV rated voltage and 50Hz frequency of AC voltage.
- **Leakage current**
The leakage current is not greater than 3.5mA.

2.3 Electromagnetic Compatibility

Power Transient Sensitivity, refer to requirements of GB6833.4.

Conducted Susceptibility, refer to requirements of GB6833.6.

Radiated interference, refer to requirements of GB6833.10.

Chapter 3 Introduction to Front and Rear Panels

Panels

The content of this chapter is only a general description. Please refer to chapter 4 for more detailed instruction.

3.1 Front panel

The front panel is show in figure 3-1.

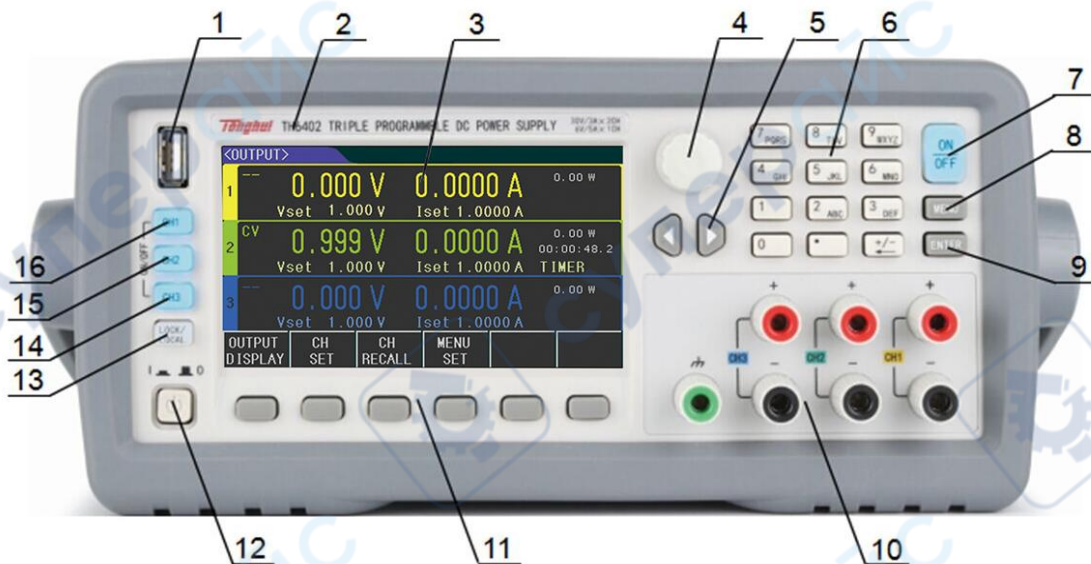

Figure 3-1

Name	Function
① USB interface	Import or export the data via the USB interface
② Trademark and model	Show instrument trademark, model, and power supply ranges
③ LCD display	480*272 dot-matrix, used for measurement setup, status, and result display etc.
④ Knob	Used for adjusting parameters, and moving arrow/cursor
⑤ Arrow keys	Left and right arrow keys used for moving the cursor
⑥ Numeric keys	Used for entering numbers
⑦ [ON/OFF] key	Turn on or off the three channel output simultaneously
⑧ [MENU] key	Quick access to menu interface
⑨ [ENTER] key	To input the data and can be used with the [LOCK/LOCAL] key to take screenshots
⑩ Output terminal	Front panel output ports, total three channels

⑪ Software menu key	To set the display content
⑫ Power switch	Power switch
⑬ [LOCK/LOCAL] key	To lock the key or switch the remote control and can be used with the [ENTER] key to take screenshots
⑭⑮⑯ Output key for 3 channels	Corresponding output/close buttons for three channels

3.2 Rear panel

Rear panel is shown in figure 3-2.

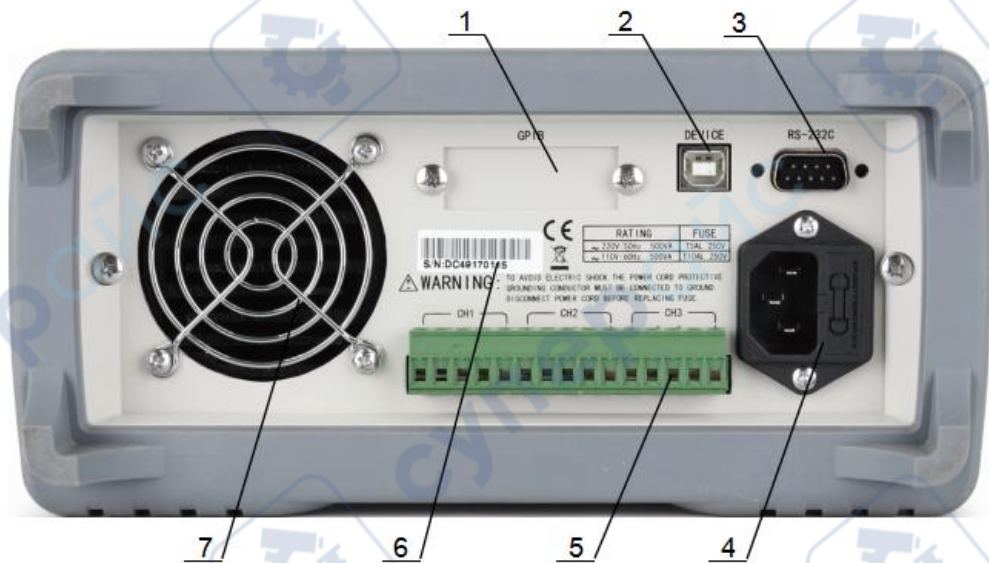

Figure 3-2

1	GPIB	Communicated with PC to build GPIB test system
2	USB	Controlled by PC via USB DEVICE
3	RS232	Function is same as No.2
4	Power socket	Connecting 220V/50HZ AC power supply
5	Remote test terminal	Same function as output in front panel, 4-terminal sampling function is added
6	Nameplate	Record production date, model, manufacturer
7	Fan	Temperature control

3.3 Zone Display

The display zone is shown below in figure 3-3.

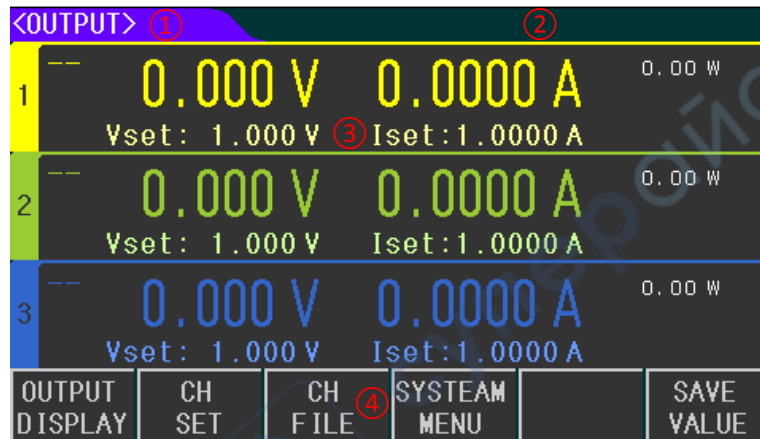

Figure 3-3

- (1.) **Display menu zone:** Display the name of current page
- (2.) **Status and error information zone:** Display the error information or current working status.
- (3.) **Fast setting and display zone:** Quickly set the voltage and current, real time display sampling values, working mode and time status.
- (4.) **Softkey menu zone:** The content is flexible, display the function matched with the adjacent softkey.

3.4 Introduction to Page Display

- **OUTPUT DISPLAY**
This page is the boot default page for quickly setting output values and displaying measurements.
- **CH SET (channel setting page)**
This page is used to set parameters of each channel
- **CH FILE (File page)**
This page is used to save the setting of the corresponding channel. When needed, the saved settings can be recalled.
- **SYSTEM MENU**
This page is used to set how the instrument works.

Chapter 4 Operation

4.1 Output display

Press **OUTPUT DISPLAY** to enter <OUTPUT> page

<OUTPUT> is displayed in figure 3-1.

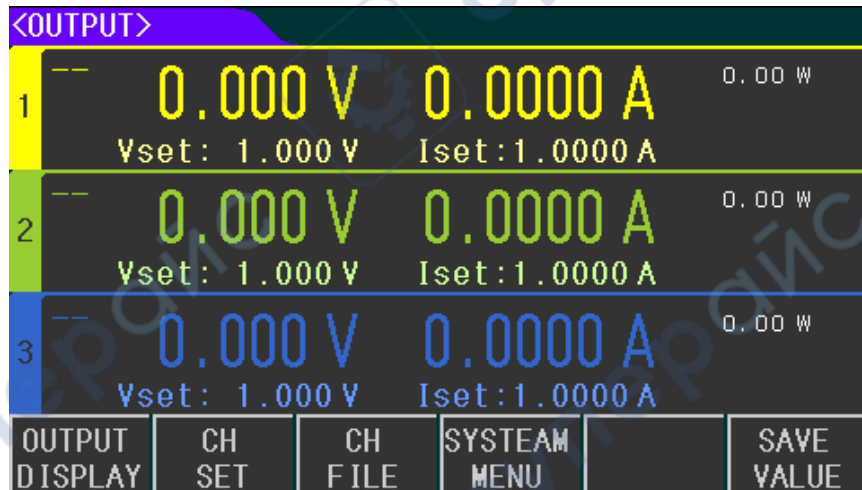

Figure 3-1

This page is used to quickly set the voltage and current of the three channels, and display the voltage value, current value, power, output time and output state.

4.1.1 Value Setting

The setting range of voltage and current of each channel is from 0 to Max. value (The Max. value depends on different models). Use the **arrow keys** to move the cursor to the desired place, and

there are 2 methods to set voltage or current:

Method A: Make use of the **knob** or **arrow keys** to move the cursor to the desired place, rotate the **knob** to adjust the value.

Method B: Use the **number keys** to input value, select the unit on the bottom zone or use **ENTER** to input the voltage or current value.

4.1.2 Output

The three buttons **CH1**, **CH2**, **CH3** on the left side of the front panel are used for turning on/off

the output of the corresponding channels.

The **ON/OFF** key is used to turn on/off the output of 3 channels at the same time.

4.2 CH SET

Press **CH SET** to enter <CH1 SET> page, and to set other channels by pressing **CH o** or **CH** to switch other channels.

CH2 SET is displayed as below:

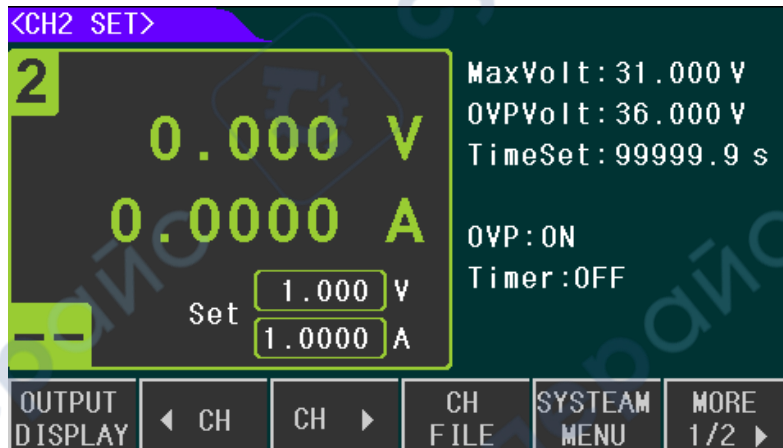

Figure 4-2

On this page, you can set the parameters of one channel, the parameters that can be set on this page are listed below:

- Voltage, current
- Max Volt
- OVP Volt
- Time Set
- OVP ON/OFF
- Timer ON/OFF
- SAVE VALUE

4.2.1 Voltage and Current Set

The setting range of voltage and current of each channel is from 0 to Max. value (The Max. value is determined by different models). Make use of the **arrow keys** to move the cursor to select voltage or current, and use the **knob** or **number keys** to set values.

4.2.2 Max. Voltage Set

The MaxVolt limits the maximum voltage that can be set to prevent the damage caused by the load bearing too much voltage due to the wrong operation in the voltage output process. The setting range of MaxVolt is between 0 and max. value (the maximum value depends on different instrument models), and the setting method is the same as that described above. After the MaxVolt has been set successfully, the maximum voltage that can be set is the MaxVolt. If the MaxVolt is less than the voltage setting value, then the voltage setting value will be set to MaxVolt.

4.2.3 OVP Volt Set

The range of OVP Volt is from 0 to Max. value (which depends on different models). The OVP function allows users to set voltage protection point. When OVP function is enabled, if the voltage in the circuit exceeds the protection point, the power supply will be OVP protected, the output will be closed, and the information bar will display the protection.

4.2.4 Time Set

The range of time set is from 0 to 99999.9s. When the Time function is on, the timer starts working in the process of outputting also the countdown value is displayed. When the countdown is finished, then the output is closed.

4.2.5 OVP Switch

As show in figure 4-3, press MORE, and enter the second picture below, press OVP to turn on or off the OVP function.



Figure 4-3

4.2.6 Time Function

Same as the above setting, select TIME to turn on or off the time function. When the Time is on then “TIMER” will be displayed on the picture below.



Figure 4-4

4.2.7 Save Value

It is used to save voltage, current, Max. Volt and OVP Volt to the File. Press SAVE VALUE to save all the setting values.

4.3 CH File

Press **CH FILE** to enter <CH1 FILE>. This page is used to save the voltage, current, MaxVolt and OVP voltage value in each channel. Each channel has one recall list, and each recall list can save up to 40 groups of data. By pressing **◀CH** or **CH▶** buttons you can switch to other channels.

<CH1 FILE> page is shown in figure 4-4.

<CH1 FILE>				
No.	Voltage	Current	MaxVolt	OVP
01	-----	-----	-----	-----
02	-----	-----	-----	-----
03	-----	-----	-----	-----
04	-----	-----	-----	-----
05	-----	-----	-----	-----
06	-----	-----	-----	-----
07	-----	-----	-----	-----
08	-----	-----	-----	-----
09	-----	-----	-----	-----
10	-----	-----	-----	-----

OUTPUT DISPLAY CH SET ◀ CH CH ▶ SYSTEM MENU

Figure 4-4

4.3.1 Recall and Delete

There are 4 pages in CH FILE, and each page can save 10 sets of data. Make use of the **arrow keys** or **PAGE UP/PAGE DOWN** buttons to switch to different pages to check the data.

When a group of data needs to be recalled, you just need to go to the page where the data is saved, rotate the **knob** to make the arrow indicator point to the group of data, and select RECALL, the group of data will overwrite the setting value. To delete a group of data, select the delete option.

Note that the data in recall list is stored temporarily, and the data will be cleared after the instrument is restarted. If you want to load the saved data after starting up, you need to save the data into Flash, For the detailed instruction, please refer to 4.4.3.

4.4 Menu Set

Press the **MENU** button to enter <SYSTEM> page, where you can set the working mode of the instrument. Move the cursor to the desired place with the **knob**, and use the software bar to do the corresponding setting.

The <SYSTEM> page is shown in figure 4-5.

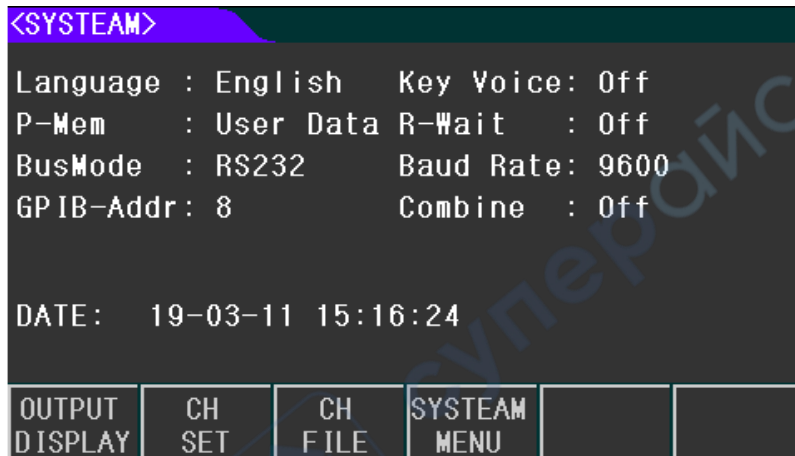

Figure 4-5

4.4.1 Language

TH6400 series power supply provides two display language.

- 中文
- ENGLISH

4.4.2 Key Voice

Based on users' needs, key voice can be turned on/off.

- ON
- OFF

4.4.3 P-Mem

The function is used to select the User Data or Default

- DEFAULT: Boot in factory Setting and does not load any saved parameters
- USER DATA: While users had already set some parameters or did some system settings, and need to restore the settings/data, this option should be selected. If there is any data modification before turning off the instrument, it is necessary to press USER DATA again to rewrite all data to Flash.
- RESTORE DEFAULT: Restore all settings to factory defaults.

4.4.4 R-Wait

This function enables the instrument to automatically return to the main display page after stopping operating for a period of time.

- Off: Turn off the function
- 5s, 30s, 60s: When the testing is on hold for a while, the instrument will return to <OUTPUT DISPLAY> page automatically.

4.4.5 Bus Mode

TH6400 series power supply provides four communication modes. Select the required communication option and connect the communication port from the rear panel to realize the corresponding communication function.

- RS232
- GPIB
- USB-CDC
- USB-TMC

4.4.6 Baud Rate

Baud rate:

- 4800
- 9600
- 19200
- 38400
- 57600
- 115.2k

4.4.7 GPIB-Addr

When the instrument needs to communicate with multiple instruments, it is necessary to set the GPIB address, such as 8.

4.4.8 Combine

This option sets the combined state of the three channels. In the combined state, data saving and recall operations cannot be performed.

- OFF: Turn off Combine
- SERIES: CH1+CH2 in serial mode, when the setting current of the two channels is the same
- PARA: CH1+CH2 in parallel, CH2+CH3 in parallel, 3 channels in parallel, when the setting voltage of the selected channels is the same
 - TRACK: CH1+CH2 in synchronous mode, CH2+CH3 in synchronous mode and 3 channels in synchronous mode. This function enables the setting voltage and setting current of the selected channel to change proportionally and synchronously. Before choosing the synchronization mode, you must set the voltage and current value.

E.g. Step 1: Set values in channels:

	Voltage	Current
CH1	2V	0.1A
CH2	1V	0.3A

Step 2: Select CH1+CH2 TRACK

After selecting this mode, if the setting value of channel 1 is changed, the setting value

of channel 2 will change accordingly. As shown in the table below:

	Voltage	Current
CH1	3V	0.2A
CH2	1.5V	0.6A

If the selected synchronization channel sets the voltage/current to 0 before synchronization, then synchronization fails.

4.4.9 Date

Th6400 series power supply has a built-in RTC clock, which can display the real time. Move the cursor to Date option and press SET button on the software bar to do the setting. Refer to the actual time to set year, month, day, hour, minute and second.

Chapter 5 Correct Use of the Instrument

Step 1: Connect the instrument to electricity supply.

Step 2: Press the power button.

Step 3: Warm-up the device for 20min.

Step 4: According to actual needs, select connection line, and connect the load to [+ , -] terminal of the instrument. When combined output is used, the output terminal of the front panel must be connected in series or in parallel according to the mode you have chosen. If back panel is used, also take the same way to do the connection.

Step 5: Set operating mode, parameters, and select the channels.

Step 6: Press the corresponding channel output button to output, or press **ON/OFF** to enable three channels output at one time.

Chapter 6 Interface and communication

TH6400 series power supply provides RS232C serial interface, GPIB parallel interface and USB interface for data transmission and remote control, but the three interfaces cannot be used at the same time. They share the same program-controlled commands but use different hardware configurations and communication protocols. This chapter describes the use of the interface, and the interface command will be introduced in chapter 6.2.

6.1 Remote Control

6.1.1 RS232 Description

Th6400 series power supply provides RS232 interface which can be used for communication with the computer. It supports robust program control commands. Through the RS232 interface, the computer is able to operate almost all the functions of instrument.

6.1.1.1 Introduction of RS232 Interface

RS-232 standard, also called as asynchronous serial communication standard, has already been widely used for data communication between computers, computer and external equipment. RS is the English abbreviation of Recommended Standard; 232, the standard number. This standard is issued by EIA in 1969, which rules to send one bit in a data line every time.

Most serial interfaces are not strictly based on RS-232 standard; Use a 25-pin connector (IMB AT uses a 9-pin connector) on each port. The most commonly used RS-232 signals are shown in the table 6-1:

Signal	Code	25 Pin Connector Pin number	9 Pin Connector Pin number
Request To Send	RTS	4	7
Clear To Send	CTS	5	8
Data Set Ready	DSR	6	6
Data Carrier Detect	DCD	8	1
Data Terminal Ready	DTR	20	4
Transmitted the data	TXD	2	3
Receive the data	RXD	3	2
Grounding	GND	7	5

Table 6-1

Like most serial ports in the world, the serial interface of this instrument is not strictly based on the RS-232 standard, but only provides a smallest subset, the signals are listed in table 6-2:

Function	Code	Pin Connector Pin Number
Transmitted Data	TXD	3
Received Data	RXD	2

Signal Ground Common	GND	5
-------------------------	-----	---

This is the easiest and cheapest way to use serial communication.

Note: The serial port pin definition of this instrument is the same as that of the standard 9-pin RS232C connector.

The RS232C connector of the instrument is a 9-pin type DB socket, and the pin sequence is shown in figure 6-1:

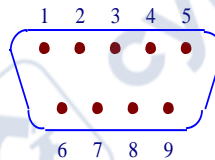

Figure 6-1

A standard DB type 9-pin plug can be connected to it directly.

Caution: To avoid electrical shock, turn off the power supply when plugging or unplugging the connector; do not short-circuit the output terminals or short-circuit the chassis to avoid damage to the device.

6.1.1.2 Communicate with PC

Connection between TH6400 series power supply and a computer shown as figure 6-2:

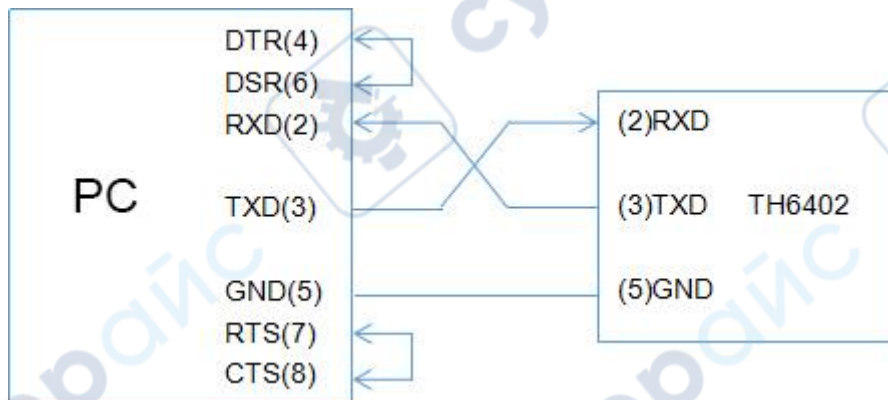

Figure 6-2

As can be seen from the above figure, the pin definition of this instrument is the same as that of the 9-pin connector serial interface pin used by the IMB AT compatible machine. Users can use the double-core shielded cable to self-make a three-wire connection cable (the length should be less than 1.5m), or purchase the serial interface cable between the computer and the instrument from our company or purchase the standard DB type 9-pin plug.

When making the connection cable, pin 4 and 6, pin 7 and 8 should be shorted respectively at the computer connector.

When use RS232 interface to communicate with the computer, you need to set the BUS MODE to RS232 from the system menu.

Serial port parameters are listed in table 6-3.

Transmission mode	Full duplex asynchronous communication including start and stop bit
Baud rate	9600 bps
Data bit	8 BIT
Stop bit	1 BIT
Verification	None
End symbol	NL (line break, ASCII code 10)
Contact	software
Connector	DB9 core

Table 6-3

6.1.2 GPIB Interface

6.1.2.1 GPIB Bus

IEEE488 (GPIB) is an international bus interface standard used on intelligent instruments. IEEE is the English abbreviation of Institute of Electrical and Electronics Engineers, and 488 is the standard number. Through this interface, this tester can communicate with PC or other intelligent devices and meanwhile can make up automatic test system with the other devices. Up to 15 devices can be connected on a same bus. This tester applies IEEE488.2 and the interface plate can be inserted in any one of the three expansion slots. Control command system is open so that user can use the PC operation interface provided by this tester or take measurements by the control command system. The control command system supports most functions of the instrument, that is to say, user can execute almost all operations on PC. Thus remote control to the instrument is realized.

When configuring a GPIB system, the following restrictions must be adhered to.

1. The total length of cable in one bus system must be less than or equal to two meters times the number of devices connected on the bus (the GPIB controller counts as one device) and the total length of cable must not exceed 20 meters.
2. A maximum of 15 devices can be connected on one bus system.
3. There are no restrictions on how the cables are connected together. However, it is recommended that no more than four piggyback connectors be stacked together on any one device.

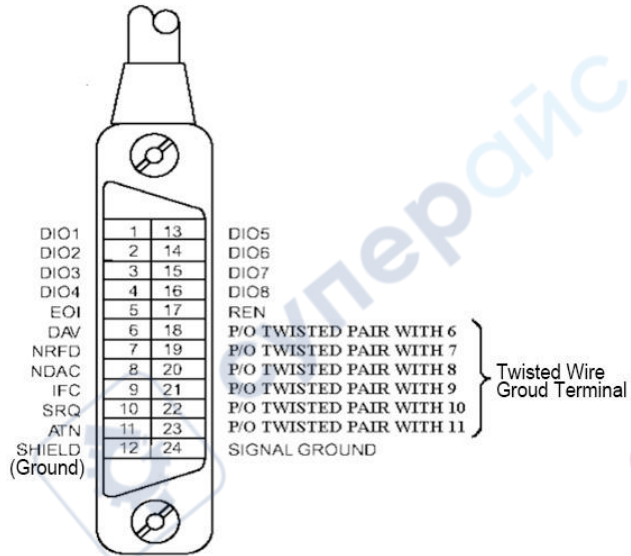

GPIB Cable Connection Method 1:

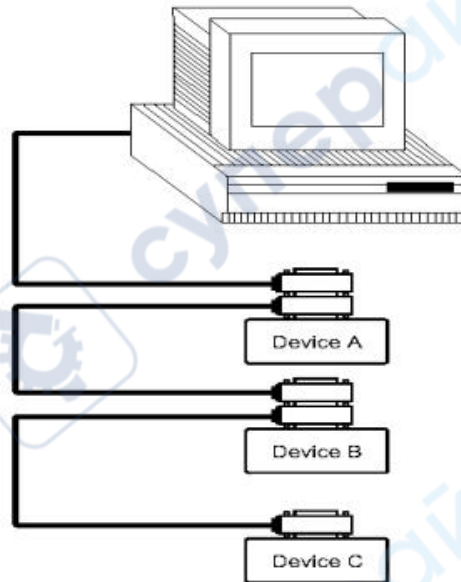

GPIB Cable Connection Method 2:

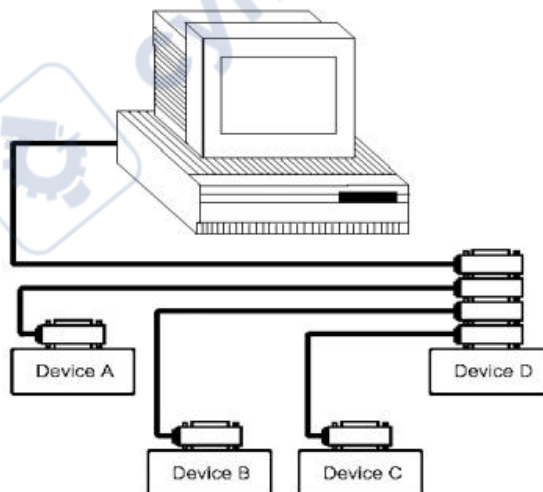

6.1.2.2 GPIB Interface Function

This instrument provides most general functions of GPIB, see in table 6-4:

Code	Function
SH1	Support all data source contact function
AH1	Support all receptor contact function
T5	Basic Talker; Cancel in MLA; Serial call is not supported
L4	Basic Listener; Cancel in MTA; no Listen only function
RL1	Remote/Local function
DC1	Device clear function
DT1	Device trigger function
C0	No controller function
E1	Open Electrode Drive

Table 6-4

6.1.2.3 GPIB Address

The instrument's GPIB is addressed in a single address mode with no secondary address. Users can set 1-32 as their own GPIB address, the default GPIB address of the TH6400 is 8.

6.1.3 USBCDC

By selecting the bus mode "USBCDC", the USB interface can be configured as a virtual serial port (VCom).

6.1.3.1 System Configuration

Connect the USB interface on the rear panel of TH6400 with the USB interface on the host with USB cable.

6.1.3.2 Install the Driver

When the device is first connected to a PC through a USB cable, the prompt information –Found New Hardware will show on the right bottom of the computer desktop, as is shown below

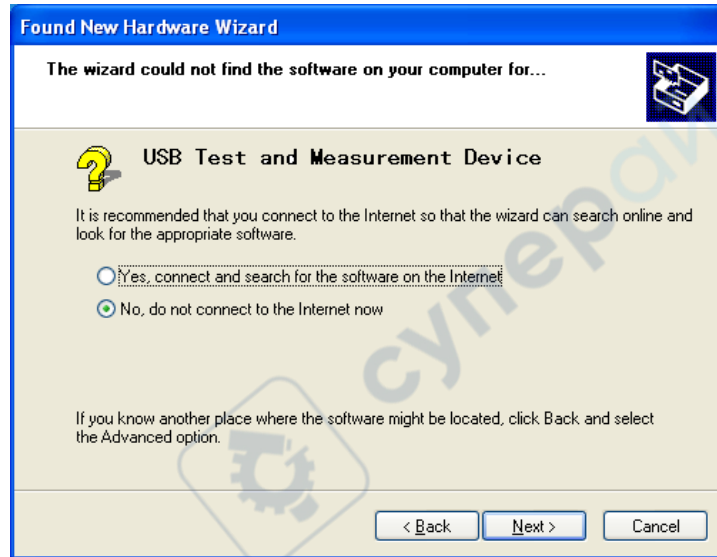

Click Next, the table below is displayed and select Install from a list or specific location



Then click Next, select the routine of the driver provided by us then Next
 When the driver is installed, you can see USB Test and Measurement Device in the device manager.

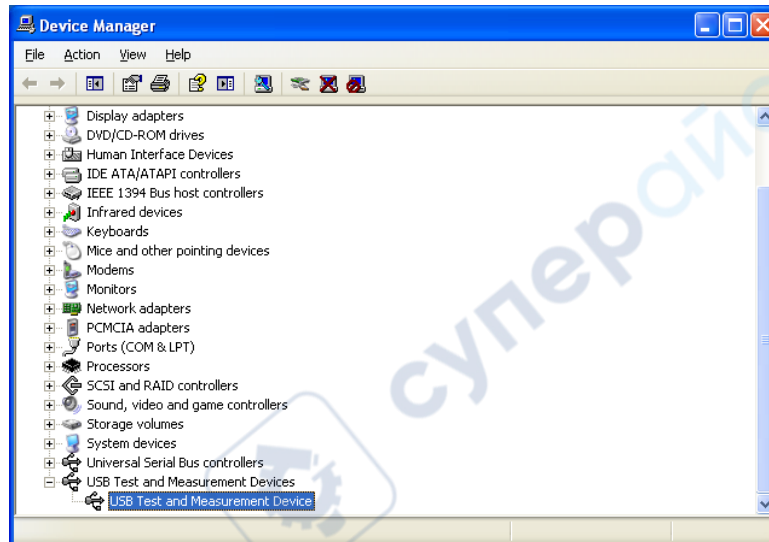

6.2 Command Instruction

Th6400 series power supply conforms to GPIB common command and SCPI (Standard Commands for Programmable Instrumentation) standard. The GPIB common command is defined by the IEEE 488.2-1987 standard and are applicable to all interfaces, but TH6400 series does not accept all the common command. SCPI command uses a hierarchical structure, and can have up to three hierarchies, where the highest level is called a subsystem command. The hierarchy under the subsystem command is valid only if the subsystem command is selected, using a colon to separate the hierarchy of the command.

6.2.1 Syntax Conventions

- (1) Cases are ignored
For example: FUNC:IMP CPD = func:imp cpd = Func:Imp CpD
- (2) A space is inserted to separate the command and the argument. The part before the space is the command, and the part after the space is the argument.
For example: FUNC: IMP CPD, IMP is the command and CPD is its argument.
- (3) Some command has no argument
For example: SYSTEM:LOCK
- (4) Space cannot be inserted before or after a colon (“_” represents a space).
For example: FUNC_:_IMP CPD → FUNC:IMP CPD
- (5) Command can be abbreviated or spelled in full (abbreviations will be given in capital letters in subsequent instructions).
For example: FUNCTION:IMPEDANCE CPD = FUNC:IMP CPD
- (6) Command followed by a question mark (?) Execute a query corresponding to this command once.
For example: FUNC:IMP?

6.2.2 Command Reference

6.2.2.1 Supported GPIB Common Command

*RST: Used for reset the instrument

*IDN?: Check the model information of the instrument

6.2.2.2 SCPI Command

Th6400 series power supply supports the following command, the command ignore cases, and the lower case letters can be omitted. Inside “<>” is the parameters, “<>” itself does not require input, “|” is used for separating parameters.

- System Command: SYSTem

- (1) SYSTem:LOCK

Set to remote control, the front panel buttons will be deactivated (except for LOCK/LOCAL buttons).

- (2) SYSTem:LOCal

Set to local operation, the front panel buttons will be activated.

- (3) SYSTem:BEEPer

Test whether the buzzer works.

- (4) SYSTem:LOCK?

Inquire the current control state and return lock or local

- (5) SYSTem:ADDRess?

Inquire the address of the instrument, and return an address value, such as ‘8’.

- Switch Page Command: DISPlay

- (1) DISPlay:PAGE <OPD | CHn | MEND>

This command is used for switching page display, the parameters inside “<>” has the following meaning:

- OPD: OutPutDisp, Output Display page
- CHn: CH1~CH3 page, 'n' is the number 1, 2 or 3 matches to 3 channels
- MEND: MenuDisp, Menu Set page

For example: disp:page opd, switch to output display page

(2) DISPlay:PAGE <SRD1|SRD2|SRD3>

- Recall List page, 'n' is the number 1,2 or 3, matches to 3 channels

(3) DISPlay?

Inquire the current page and return the value of the page abbreviation, such as "opd".

- Channel Selection Command: INSTRument

(1) INSTRument[:SElect] <FIRst|SECOnd|THIrd>

This command is used to select the operating channel.

(2) INSTRument:NSElect <1|2|3>

This command is used to select the operating channel.

(3) INSTRument:NSElect?

Inquire the current selected channel.

(4) INSTRument[:SElect]?

Inquire the current selected channel, and return first, second or third.

- Output Command: OUTPut

(1) OUTPut <0|1|ON|OFF>

This command is used to turn on/off output.

(2) OUTPut?

Inquire the output status of the selected channel, and return 0 or 1.

- Voltage Setting Command: VOLTage

(1) VOLTage <set value|MIN|MAX>

This command is used to set the voltage value of selected channel, the parameters within

"<>" are shown below:

- Set value: the voltage value

- MIN: Min. value 0
- MAX; Max. voltage value, which can be set

(2) VOLTage?

Inquire the voltage setting value of the selected channel

(3) VOLTage:PROTection <set value|MIN|MAX>

This command is used to set over voltage protection value, the minimum is 0, and the maximum depends on different models.

(4) VOLTage:PROTection?

Inquire the over voltage protection value of the selected channel.

(5) VOLTage:MAXvolt <set value|MIN|MAX >

This command is used to set the upper voltage limit of the selected channel, so that the setting value of this channel cannot exceed it.

(6) VOLTage:MAXvolt?

Inquire the upper voltage limit of the selected channel.

● Current Setting Command: CURRent

(1) CURRent <set value |MIN|MAX >

This command is used to set the current value of selected channel, the parameters within “<>” shown below:

- Set value: current value
- MIN: Min. value 0
- MAX: Max. value, which depends on different models

(2) CURRent?

Inquire the current set value of the selected channel.

- Timer Set Command: TIMer

(1) TIMer <0|1|ON|OFF>

This command is used to control the timer switch of the selected channel.

(2) TIMer?

Inquire the timer switch's status of the selected channel, return 0 or 1

(3) TIMer:DATA <0~99999.9>

This command is used to set the time of selected channel, Min. value is 0 and Max. value is 99999.9s

(4) TIMer:DATA?

Inquire the time setting value of the selected channel

- Complex Control Command: APPLy

(1) APPLy:VOLTagE <voltage value>,< voltage value >,< voltage value >

This command is used to set the voltage value of 3 channels

(2) APPLy:VOLTagE?

Inquire the voltage value of 3 channels

(3) APPLy: MAXvolt <voltage value>,< voltage value >,< voltage value >

This command is used to set the Max. voltage value of 3 channels

(4) APPLy: MAXvolt?

Inquire the Max. voltage value of 3 channels

(5) APPLy:PROTection <voltage value>,< voltage value >,< voltage value >

This command is used to set the over voltage protection value of 3 channels

(6) APPLy: PROTection?

Inquire the over voltage protection value of 3 channels

- (7) APPLy:CURRent <current value>,< current value >,< current value >

This command is used to set the current value of 3 channels

- (8) APPLy:CURRENT?

Inquire the current value of 3 channels

- (9) APPLy:TIMer:DATA <timer value>,<timer value >,< timer value >

This command is used to set the time value of 3 channels

- (10) APPLy: TIMer:DATA?

Inquire the timer value of 3 channels

- (11) APPL:OUT <0|1|ON|OFF>,<0|1|ON|OFF>,<0|1|ON|OFF>

This command is used to control the output of 3 channels

- (12) APPL:OUT ?

Inquire the output status of 3 channels

- Measuring Command: MEASure

- (1) MEASure:VOLTage?

Inquire the measured voltage value.

- (2) MEASure:CURRent?

Inquire the measured current value.

- (3) MEASure:TIMer?

Inquire the current timer value.

- (4) MEASure:POWer?

Inquire the measured power value.

- (5) MEASure:VOLTage:ALL?

The command is used to inquire the voltage value of all channels

- (6) MEASure:CURRent:ALL?

Inquire the current value of all channels

- (7) MEASure:TIMer:ALL?

The command is used to inquire the timer value of all channels

- (8) MEASure:POWer:ALL?

Inquire the measured power value of all channels

- Recall Command FUNCTION

- (1) FUNCTION SAVE

This command is used to save voltage, current, Max. voltage and over voltage protection setting values of the selected channel to the recall list.

- (2) FUNCTION:RECall <1~40>

This command is used to recall a set of data from the recall list of the selected channel.

- (3) FUNCTION:RECall? <1~40>

Inquire a set of data from the recall list of the selected channel.

- (4) FUNCTION:DELete <1~40|ALL>

This command is used to delete a set of data or clear the entire list.

- Menu Function Command: MEnu

- (1) MEnu:LANG <0|1|EN|CN>

This command is used to select the language, 0 and CN represent Chinese, 1 and EN represent English.

- (2) MEnu:LANG?

Inquire the current selected language, return cn or en.

- (3) `MENu:VOICe <0|1|ON|OFF>`

This command is used to turn on/off buzzer.

- (4) `MENu:VOICe?`

Inquire the buzzer is on or off.

- (5) `MENu:PMEM <0|1|RESet|LOAD>`

This command is used to set power on memory status, 0 and RESet means restore to default, 1 and LOAD means restore the saved data.

- (6) `MENu:PMEM?`

Inquire the state of electric.

- (7) `MENu:RWAIT <0s|5s|10s|20s|30s|60s>`

The command is used to set the loopback test waiting time.

- (8) `MENu:RWAIT?`

Inquire the loopback test waiting time.

- (9) `MENu:COMBine <0~7>`

This command is used to set the combination mode, 0~7 represent different combination modes. For detailed instruction of the combination mode, please refer to 4.4.8.

- (10) `MENu:COMBine:<PARAllel|TRACk>,<1|2|3>`

This command is used to set the combination mode.

- (11) `MENu:COMBine?`

Query the combination mode of the instrument.

- Date Clock Command: DATE

- (1) `DATE:<YEAR|MONth|DATE|HOUR|MIN|SEC> <set value>`

This command is used to set RTC clock, the parameters in the first “<>” are year,

month, date, hour, minute, second, and in the second “<>” is the required value

(2) DATE?

Inquire the current date.

Chapter 7 Specification

TH6402				
Parameter		CH1	CH2	CH3
Rated output (0°C ~ 40°C)	Voltage	0~30V	0~30V	0~6V
	Voltage limit	0~36V	0~36V	0~11V
	Current	0~3A	0~3A	0~5A
	Power	210W		
Load regulation	Voltage	≤0.01%+3mV		
	Current	≤0.1%+3mA		
Power supply regulation	Voltage	≤0.01%+3mV		
	Current	≤0.1%+3mA		
Resolution of set value	Voltage	1mV		
	Current	0.1mA		
Resolution of reread value	Voltage	1mV		
	Current	0.1mA		
Resolution of set value (25°C ±5°C)	Voltage	≤0.03%+10mV		
	Current	≤0.1%+5mA		
Resolution of reread value (25°C ±5°C)	Voltage	≤0.03%+10mV		
	Current	≤0.1%+5mA		
Ripple and noise (20Hz-20MHz)	Voltage(Vp-p)	≤3mVp-p	≤3mVp-p	≤4mVp-p
	Voltage(rms)	≤1mVrms	≤1mVrms	≤1mVrms
	Current	≤3mA _{rms}	≤3mA _{rms}	≤5mA _{rms}
Factor of output temperature (0°C ~ 40°C)	Voltage	≤0.03%+10mV		
	Current	≤0.1%+5mA		

Temperature factor of reread value	Voltage	$\leq 0.03\% + 10\text{mV}$		
	Current	$\leq 0.1\% + 5\text{mA}$		
Series Synchronization Error		$\leq 0.05\% + 10\text{mA}$		
Accuracy of parallel set value	Voltage	$\leq 0.02\% + 5\text{mV}$		
	Current	$\leq 0.1\% + 20\text{mA}$		
Memory	Save/load	40 group	40 group	40 group
Timer	Function	Turn off output at fixed time 定时关闭输出		
	Time set	0.1s~99999.9s		
	Resolution	0.1s		
Working temperature		0°C ~ 40°C		

TH6412				
Parameter		CH1	CH2	CH3
Rated output (0°C ~ 40°C)	Voltage	0~30V	0~30V	0~6V
	Voltage limit	0~36V	0~36V	0~11V
	Current	0~6A	0~6A	0~5A
	Power	390W		
Load regulation	Voltage	$\leq 0.01\% + 3\text{mV}$		
	Current	$\leq 0.01\% + 3\text{mA}$		
Power supply regulation	Voltage	$\leq 0.01\% + 3\text{mV}$		
	Current	$\leq 0.01\% + 3\text{mA}$		
Resolution of set value	Voltage	1mV		
	Current	0.1mA		
Resolution of reread value	Voltage	1mV		
	Current	0.1mA		
Resolution of set value (25°C $\pm 5^\circ\text{C}$)	Voltage	$\leq 0.03\% + 10\text{mV}$	$\leq 0.03\% + 10\text{mV}$	$\leq 0.03\% + 10\text{mV}$
	Current	$\leq 0.1\% + 8\text{mA}$	$\leq 0.1\% + 8\text{mA}$	$\leq 0.1\% + 5\text{mA}$
Resolution of reread value (25°C $\pm 5^\circ\text{C}$)	Voltage	$\leq 0.03\% + 10\text{mV}$	$\leq 0.03\% + 10\text{mV}$	$\leq 0.03\% + 10\text{mV}$
	Current	$\leq 0.1\% + 8\text{mA}$	$\leq 0.1\% + 8\text{mA}$	$\leq 0.1\% + 5\text{mA}$
Ripple and noise (20Hz-20MHz)	Voltage(Vp-p)	$\leq 4\text{mVp-p}$		
	Voltage(rms)	$\leq 1\text{mVrms}$		
	Current	$\leq 5\text{mA}_{\text{rms}}$		
Factor of output temperature (0°C ~ 40°C)	Voltage	$\leq 0.03\% + 10\text{mV}$		
	Current	$\leq 0.1\% + 5\text{mA}$		
Temperature factor	Voltage	$\leq 0.03\% + 10\text{mV}$		

of reread value	Current	$\leq 0.1\% + 5\text{mA}$		
Parallel	Voltage	$\leq 0.02\% + 5\text{mV}$		
Synchronization Error	Current	$\leq 0.1\% + 30\text{mA}$		
Memory	Save/load	40group	40group	40group
Timer	Function	Turn off output at fixed time		
	Time set	0.1s~99999.9s		
	Resolution	0.1s		
Working temperature		0°C~40°C		

TH6413				
Parameter		CH1	CH2	CH3
Rated output (0°C~40°C)	Voltage	0~60V	0~60V	0~6V
	Voltage limit	0~65V	0~65V	0~11V
	Current	0~3A	0~3A	0~5A
	Power	390W		
Load regulation	Voltage	$\leq 0.01\% + 3\text{mV}$		
	Current	$\leq 0.01\% + 3\text{mA}$		
Power supply regulation	Voltage	$\leq 0.01\% + 3\text{mV}$		
	Current	$\leq 0.01\% + 3\text{mA}$		
Resolution of set value	Voltage	1mV		
	Current	0.1mA		
Resolution of reread value	Voltage	1mV		
	Current	0.1mA		
Resolution of set value (25°C±5°C)	Voltage	$\leq 0.03\% + 10\text{mV}$		
	Current	$\leq 0.1\% + 5\text{mA}$		
Resolution of reread value (25°C±5°C)	Voltage	$\leq 0.03\% + 10\text{mV}$		
	Current	$\leq 0.1\% + 5\text{mA}$		
Ripple and noise (20Hz-20MHz)	Voltage(Vp-p)	$\leq 4\text{mVp-p}$	$\leq 4\text{mVp-p}$	$\leq 4\text{mVp-p}$
	Voltage(rms)	$\leq 1\text{mVrms}$	$\leq 1\text{mVrms}$	$\leq 1\text{mVrms}$
	Current	$\leq 4\text{mA rms}$	$\leq 4\text{mA rms}$	$\leq 5\text{mA rms}$
Factor of output temperature (0°C~40°C)	Voltage	$\leq 0.03\% + 10\text{mV}$		
	Current	$\leq 0.1\% + 5\text{mA}$		
Temperature factor of reread value	Voltage	$\leq 0.03\% + 10\text{mV}$		
	Current	$\leq 0.1\% + 5\text{mA}$		
Parallel Synchronization Error	Voltage	$\leq 0.02\% + 10\text{mV}$		
	Current	$\leq 0.1\% + 30\text{mA}$		
Memory	Save/load	40group	40group	40group
Timer	Function	Turn off output at fixed time		

	Time set	0.1s~99999.9s
	Resolution	0.1s
Working temperature		0°C~40°C