

BLUER



PLEASE READ FIRST

Please read this manual thoroughly before assembling and turning on the printer!

DANGER AND WARNING

The 3D printer machine contains electric and heating parts. When the printer is working, please use it in a safe environment.

RISK OF ELECTRIC SHOCK

When the machine is powered on, never open the bottom of the machine. To open the bottom, turn off the power and unplug the power cord.

RISK OF BURNS

Before the hot end is completely cold, do not touch the hot end part, this part may take up to 10 minutes to cold.

FIRE HAZARD

When the machine is running, do not place flammable materials and liquids around the printer to maintain a good environment for the machine.

RISK OF PINCHING

When the printer is running, be careful not to put your fingers on moving parts, including belts, pulleys, gears, rollers or screws.

STATIC ELECTRICITY

Before touching the printer, especially the electronic equipment, make sure you are grounded. Static electricity can damage electronic components. To ground yourself, touch a grounded power source.

AGE WARNING

Minors and children are advised to be accompanied by adults to avoid danger.

CONTENTS





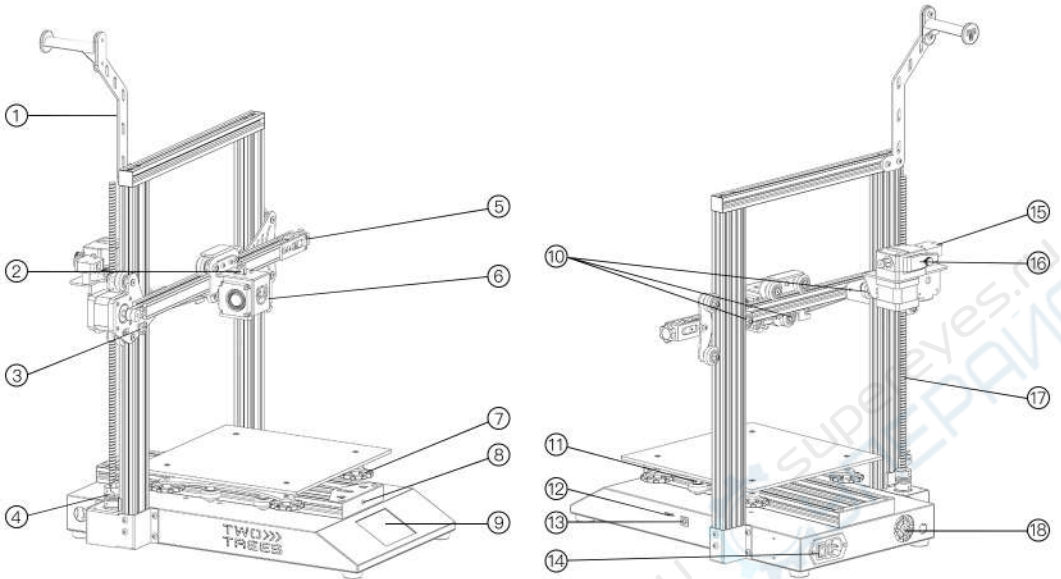





Please Read First	01
Contents	02
To Know Your Printer & Parts List	03
Machine Parameters	04
Assembly Process	05
Robin Nano Type Of Error And Solution	16
Checking And Adjust Before Use	17
FAQ Contents	18
Motherboard Installation Method	23
Driver Description	24
After-Sales Service	25
Letter For Thank You	26

TO KNOW YOUR PRINTER

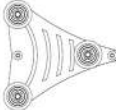

- | | | |
|--|---------------------------------|---------------------|
| 1. Filament Holder | 7. Bed Leveling Screw | 13. USB Ports |
| 2. Teflon Tube Interface | 8. Y-Axis Stretch Straighten | 14. Power Switch |
| 3. X-Axis Limit Switch | 9. 3.5" Inch Color Touch Screen | 15. Filament Sensor |
| 4. Coupling | 10. Gap Adjustment Nut | 16. BMG Extruder |
| 5. X-Axis Stretch Straighten Tensioner | 11. Gap Adjustment Nut | 17. T8 Lead Screw |
| 6. Extruder Head | 12. SD Card Slot | 18. Cooling Fan |

PARTS LIST

- | | | | |
|---|---|---|--|
|  |  |  |  |
| 1 Extruder Head x 1 | 2 Base Frame x 1 | 3 Left Frame x 1 | 4 Right Frame x 1 |
|  |  |  |  |
| 5 X-Axis Frame x 1 | 6 Right Slide x 1 | 7 Lead 8 Screw x 1 | 8 Filament Holder x 1 |
|  |  |  |  |
| 9 AC Cable&USB x 1 | 9 Filament x 1 | 10 Screw&Switch Bag x 2 | 11 Tool Bag x 1 |

MACHINE PARAMETERS

BASIC PARAMETERS

Model: BLUER	Printing Speed: 20~200mm/s
Print Size: 235*235*280mm	Extruder Head Temperature : ≤260°C
Machine Size: L418*W328*H492mm	Heat Bed Temperature : ≤100°C
Machine Material: Sheet Metal	Printing Platform : Heat Bed & Pasting platform
Number Of Nozzle: 1	Support Filament: PLA/PETG/Wood
Nozzl Size: 0.4mm	Filament Diameter : 1.75mm
Printing Accuracy: ±0.1–0.2mm	Language : Chinese、English、French、 Spanish、German、Korean、Russian
Layer Thickness: 0.1–0.4mm	Software Format: STL、OBJ、JPG
Printing Method: SD card Online Printing (PC)	Print File Format: Gcode
Display: 3.5" Color Touch Screen	Operating System: Windows, MAC
Power Supply: 220V/110V 240W	Support Software: Repetier–Host、Cura...
Machine Speed: 10~300mm/s	

1. Install the left frame

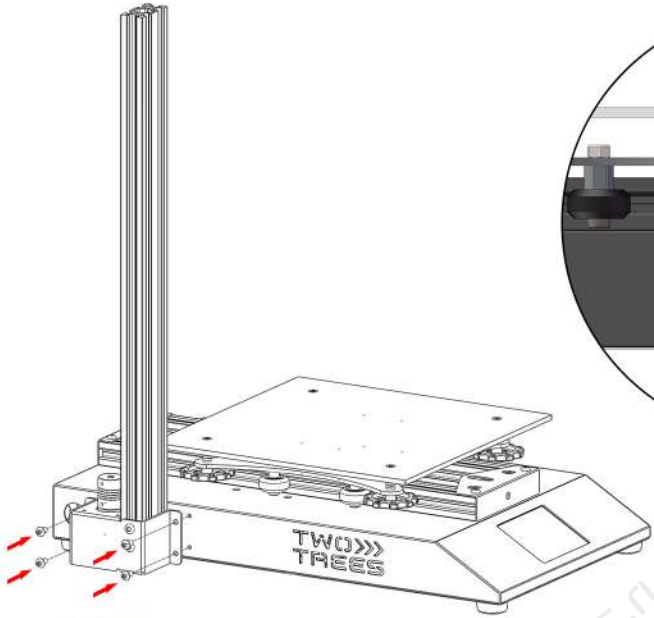

M4*8 Screw

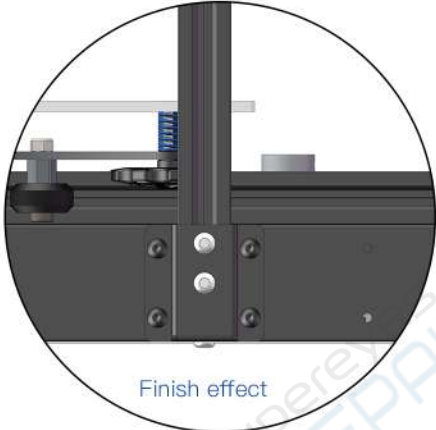

Finish effect

2. Install the right frame

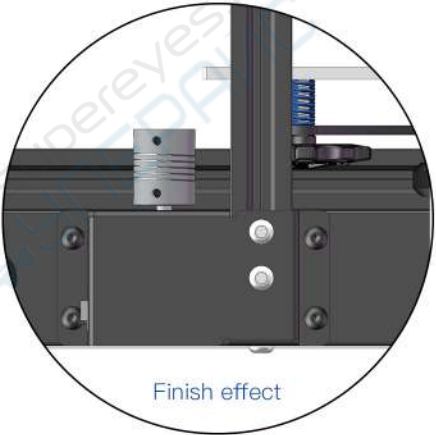

Finish effect

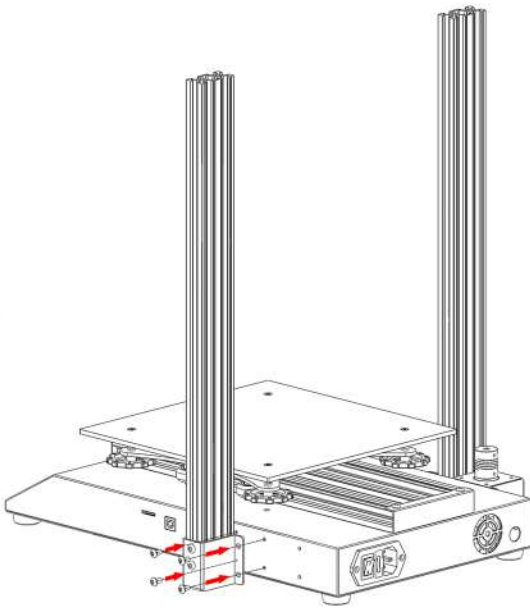

M4*8 Screw

3. Install the X-axis frame

- The X-axis frame is inserted from bottom to top, and the POM wheel slowly slides into the V-shaped groove of the left column. Be careful not to press in forcefully to avoid damage to the POM wheel. Too tight or too loose, you can adjust the tightness by adjusting the eccentric nut.
- The guide 8 screw rod is installed in a clockwise direction from the middle of the brass nut.
- After the guide 8 screw rod is twisted into the length 1/2, insert the screw rod down into the hole of the coupling, tighten the 2*M3 top screw, clamp the screw rod, and check whether it is tight.

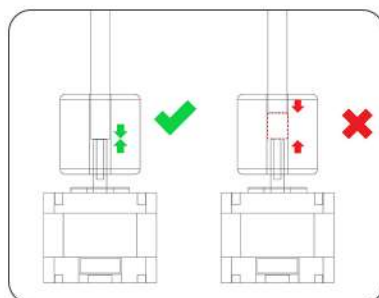
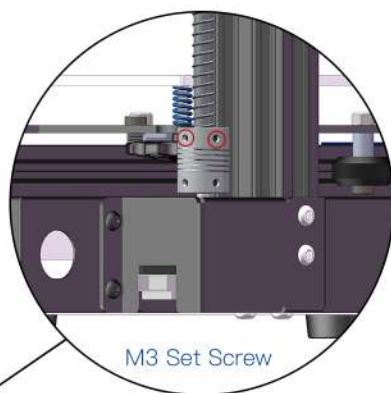
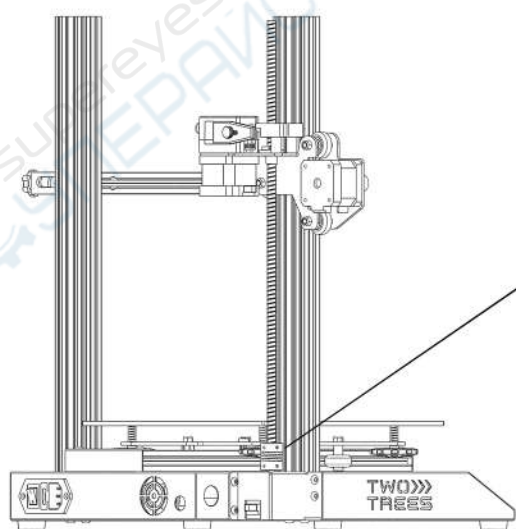
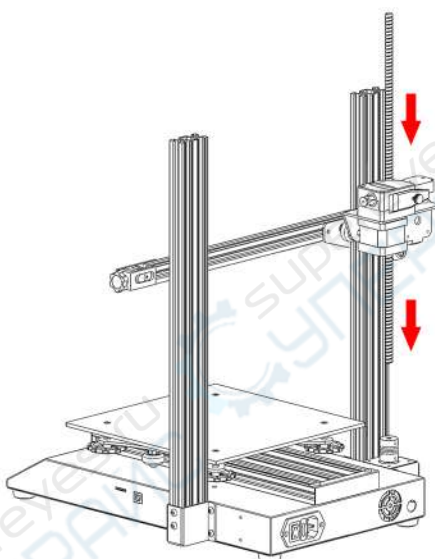
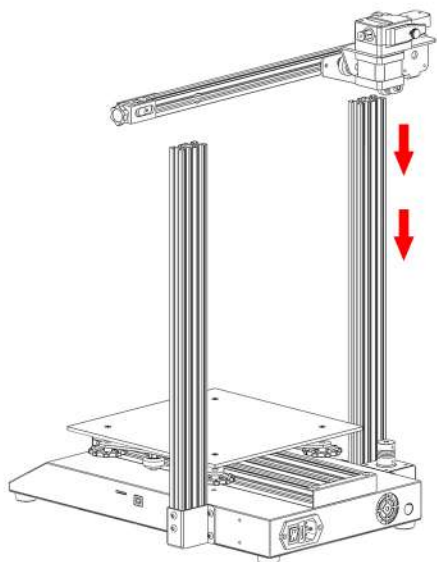

 Note

4. Install the right slider

- The right slider is inserted from bottom to bottom, and the POM wheel slowly slides into the V-shaped groove of the left column. Be careful not to press in forcefully to avoid damage to the POM wheel. Too tight or too loose, you can adjust the tightness by adjusting the eccentric nut.
- Fix it with the X-axis frame by M4*8 screws and T-nuts.

Remarks: When it is not tightly fixed with the X-axis frame, you can make sure that they are fixed together by loosening the screws and tightening again.

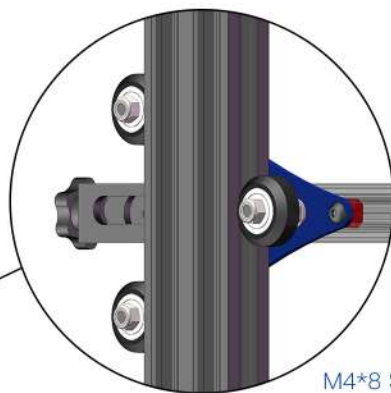
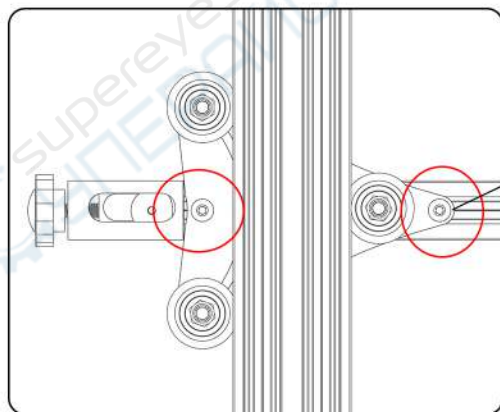
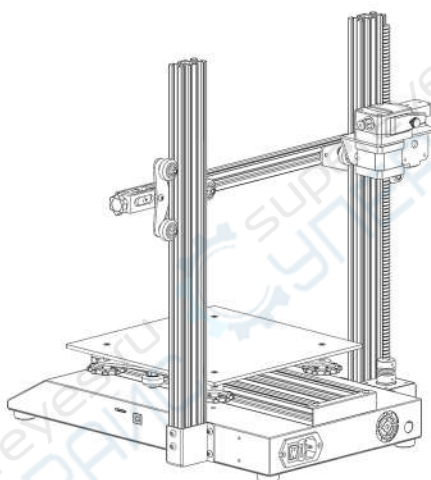
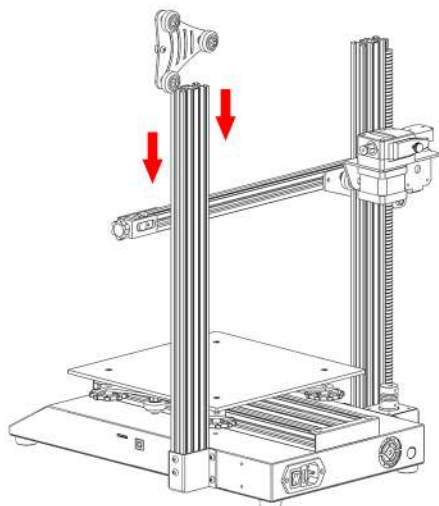

M4*8 Screws

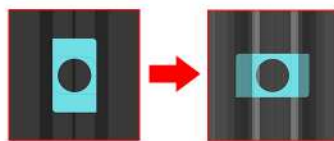

 Please turn clockwise
Screw drive nut and fix

5. Install the top beam

The top beam is fixed on the left and right columns with 4XM5*25 long screws, and the guide 8 screw is manually rotated to test whether the up and down movement is smooth without jamming or shaking, such as jamming or shaking. Check whether the fixed position of the top beam is appropriate. Adjustment.

M4*8 Screw

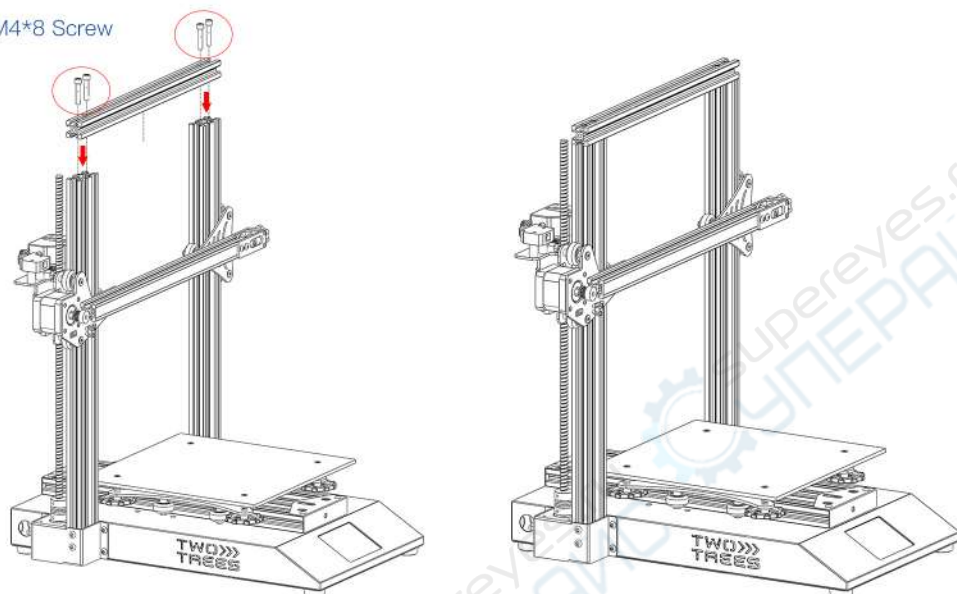

6. Install the Extrusion Head

- Push the extrusion head into the V groove of the X-axis frame from left to right, and the belt passes under the POM wheel.
- Loosen the X-axis tensioner first, fix both ends of the belt on the extruder support, and then tighten the belt.

Remarks: The cable tie on the belt faces the back of the machine to avoid false triggering of the limit switch.

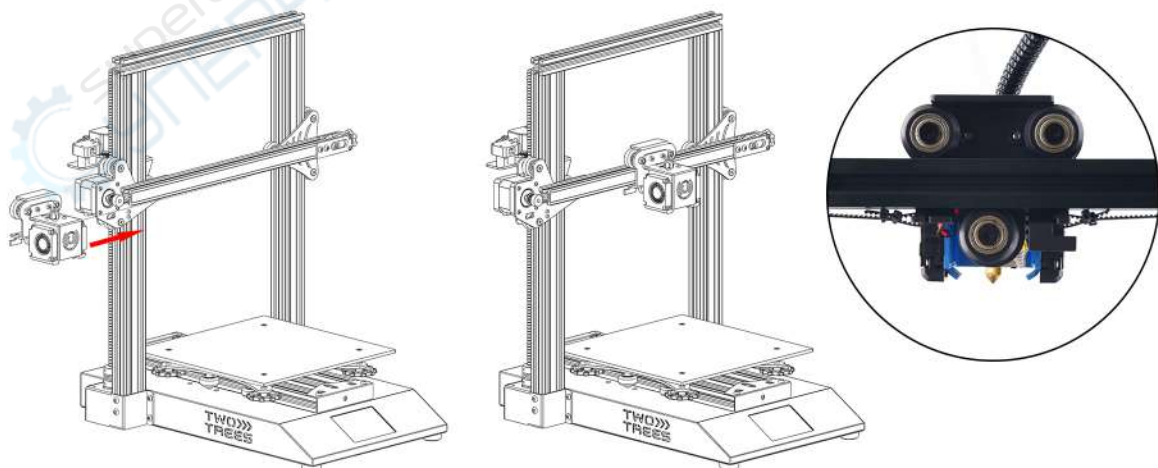

7. Install limit Switch

- The X-limit switch shrapnel faces the upper left direction and is fixed by 2XM2*10 screws, pay attention to the direction.
- The Z-limit switch faces the outside direction and is fixed by M4*6 screws and T-nuts.

Remarks: The position of the Z-axis limit switch is determined. You can determine the proper position by moving the extruder nozzle to the hot bed and then moving the Z-limit switch to just trigger the limit switch.

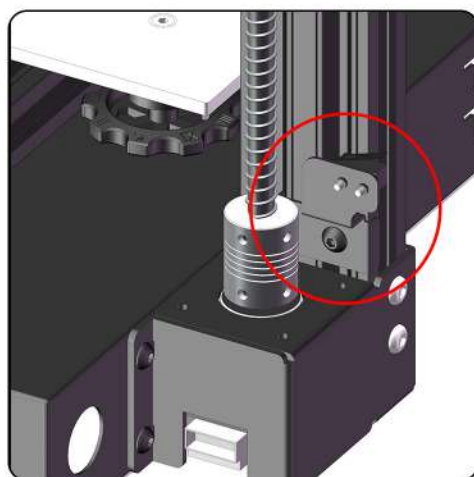
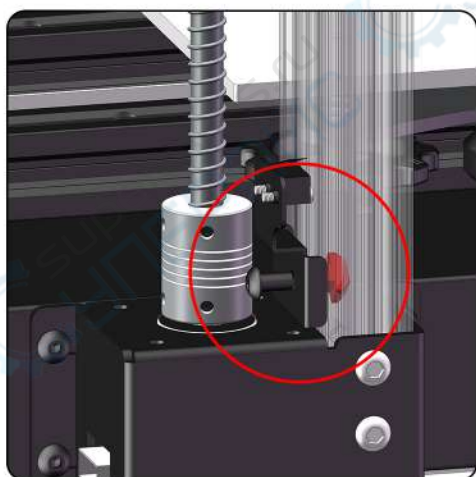
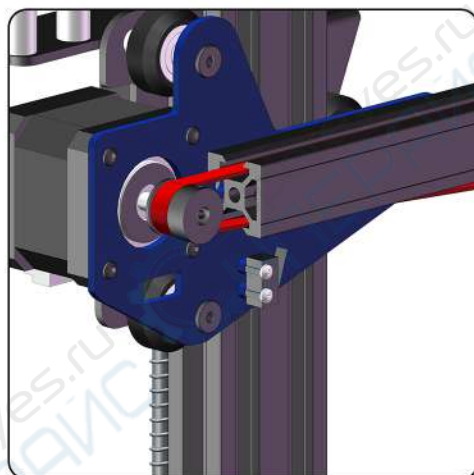
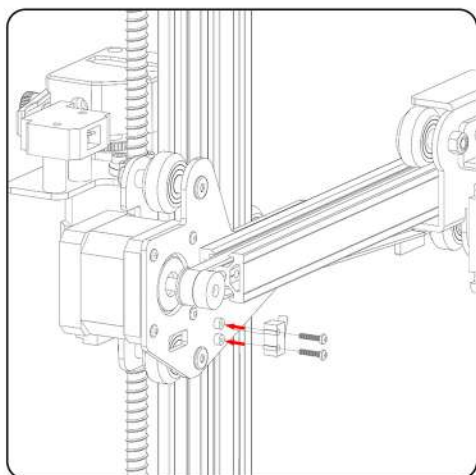

8. Install the Filament Holder

- The sheet metal bracket and the plastic barrel are fixed by 2XM4*8 screws.
- The sheet metal bracket and the machine are fixed by 2XM4*8 screws and 2XT type nuts.

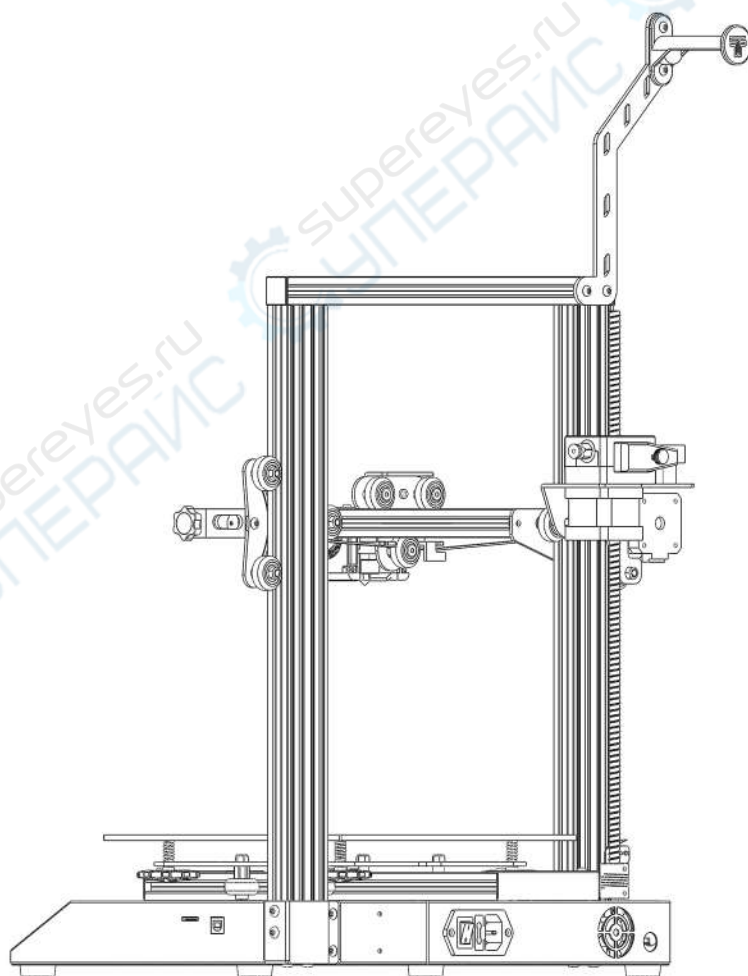
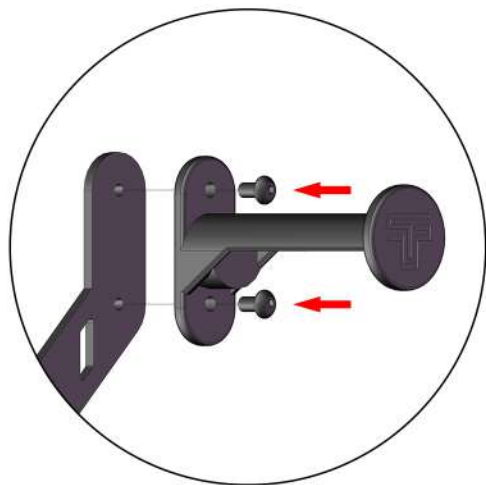

9. Wiring

Wiring list:

1. E-motor port (extrusion)
2. Material break detection port
3. X-limit switch port
4. X-motor port
5. Z-limit switch port
6. Detect hot bed line port

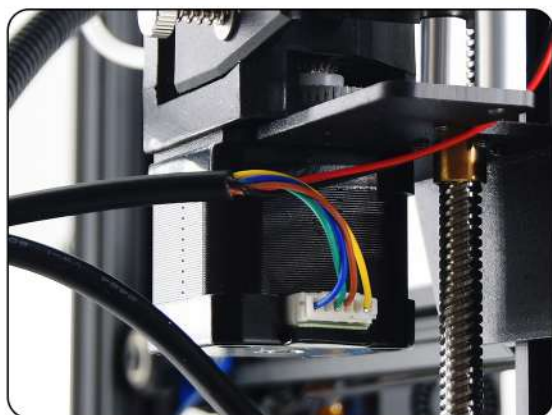

1



2

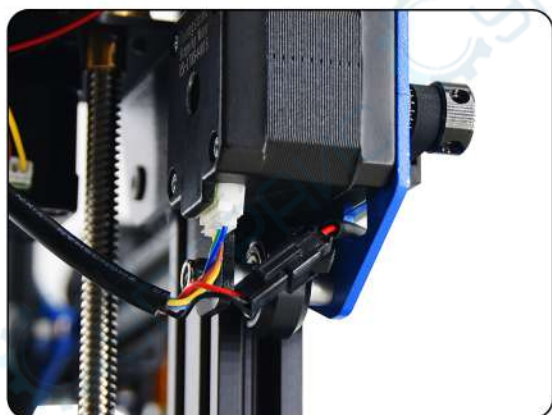

3

4



5

6

10. Teflon tube Installation

One end of the Teflon tube is inserted into the BMG quick connector, and the other end is inserted into the extrusion head quick connector.

Remarks: The pipe inserted into the extruder should be inserted deep enough. Refer to the depth in the schematic diagram. It can be pulled out twice and compared with the position of the extruder shell and heating block to determine whether it has reached the end.

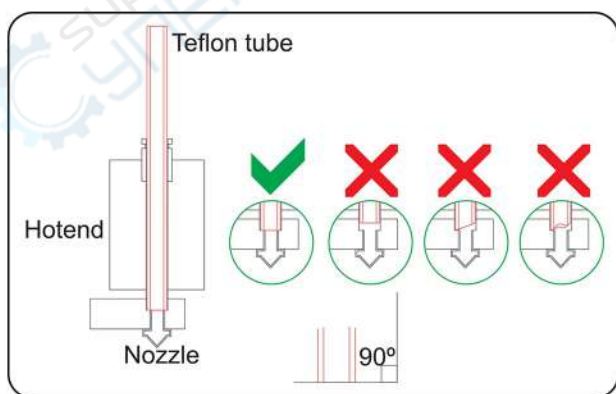
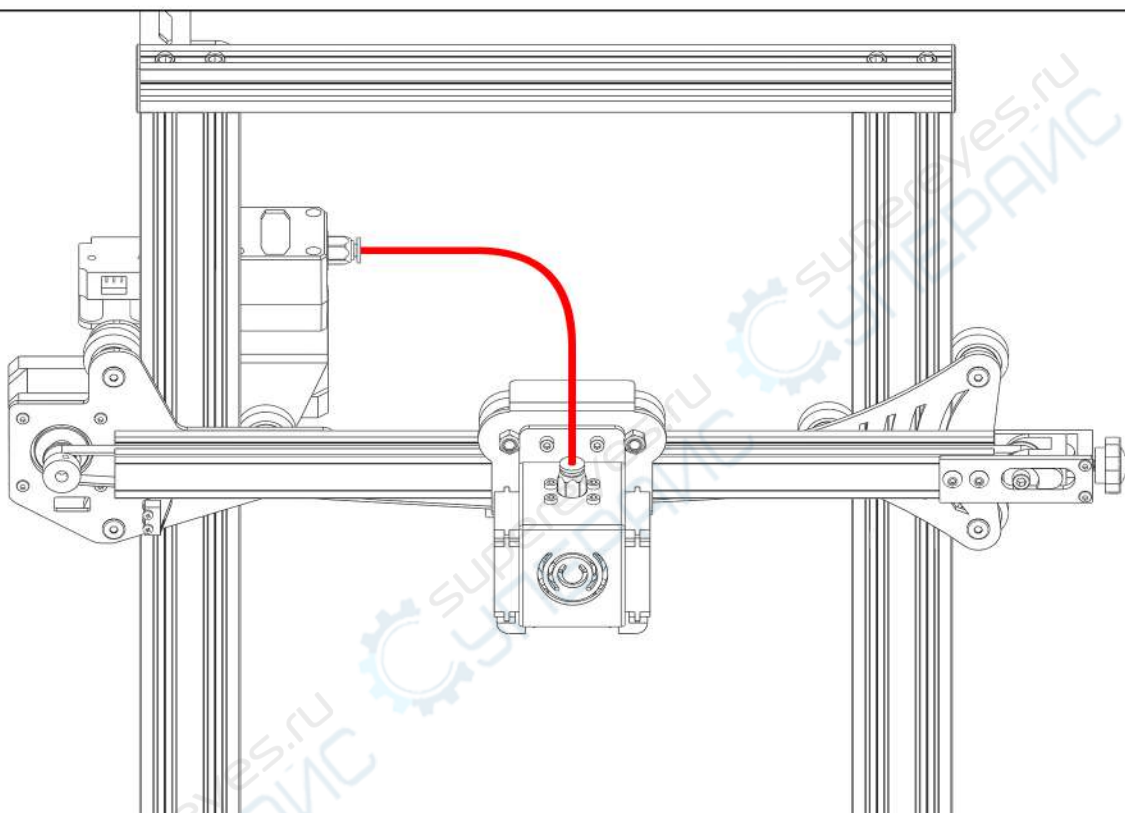

Installation depth reference



Teflon tube

11. Belt tension adjustment method

Function: Tighten the X and Y belts to improve the quality of printed products.

Operation: Tighten the tightening screw clockwise appropriately to make the extruder and the hot bed not shake.

1. Loosen the M3 screw

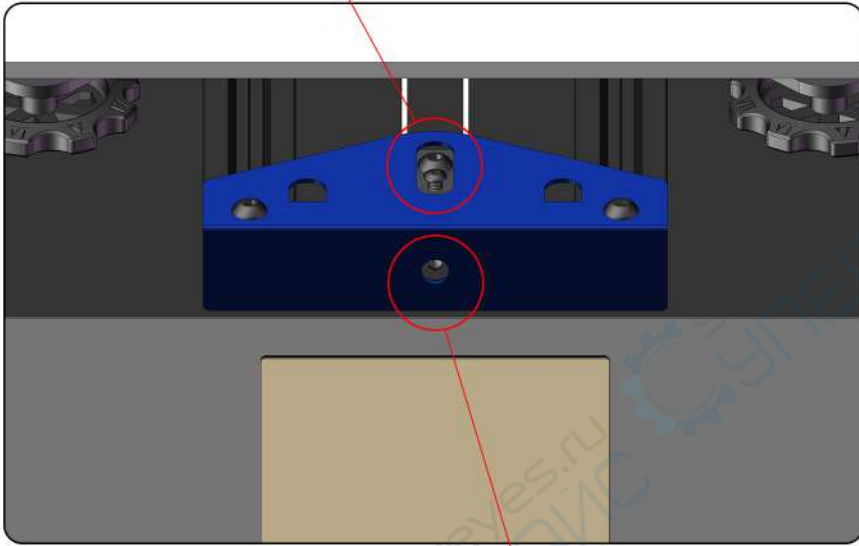

2. Turn the M5 screw inside clockwise to tighten the Y-axis belt

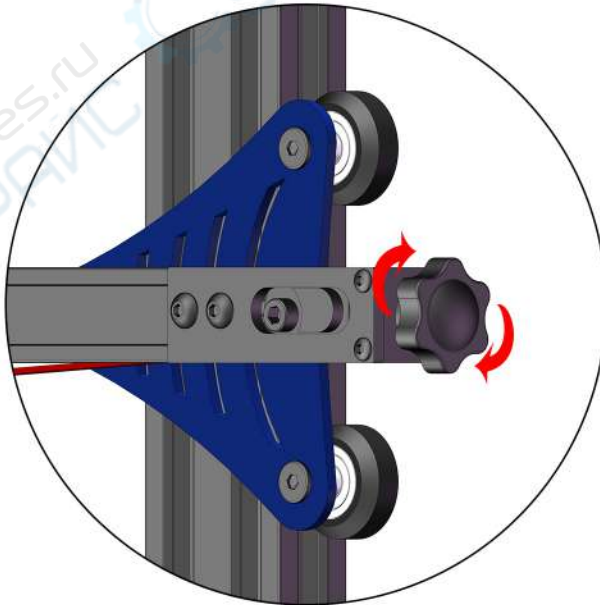

Rotate clockwise to tighten the X axis belt

12. Adjustment method of eccentric nut:

Function: The gap can be adjusted to make the mechanical transmission more stable, without jamming or shaking.

Operation: Tighten the eccentric nut identified in the picture with a 10MM open-end wrench, turn the eccentric nut a bit clockwise to test whether the clamping is smooth, and repeat the operation until the clamping is smooth (the machine has 5 eccentric nuts).

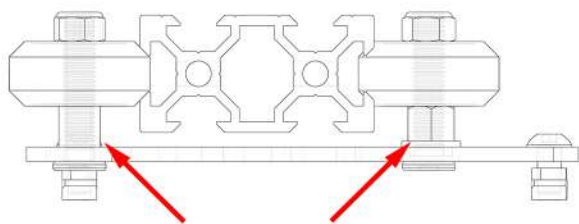
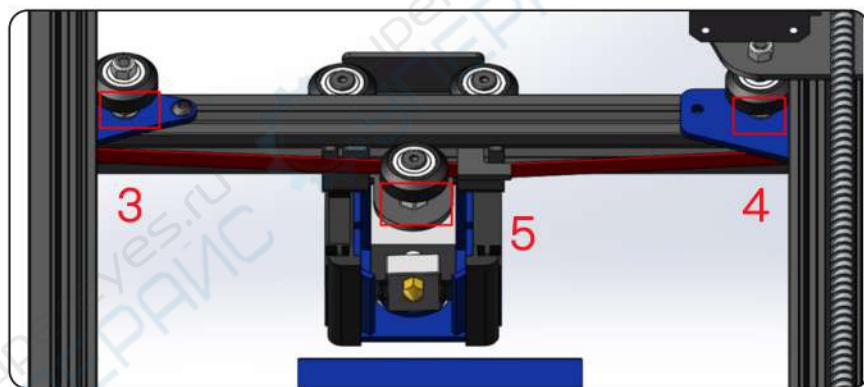
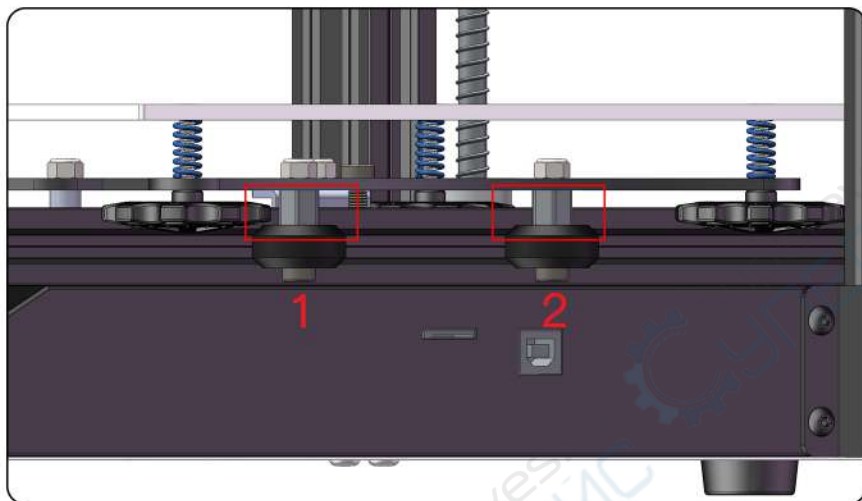

Eccentric nut



Tools used: open-end wrench

CHECKING AND ADJUST BEFORE USE

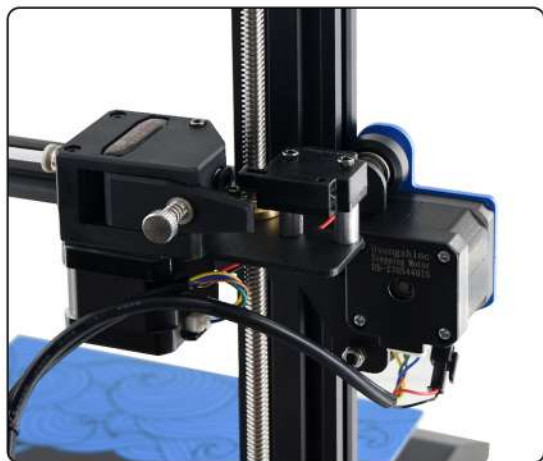

ROBIN NANO

TYPE OF ERROR AND SOLUTION

- ERR1:** The hot bed exceeds the maximum temperature limit, please check whether the thermal interface is shorted;
- ERR2:** The nozzle exceeds the maximum temperature limit, please check whether the thermal interface is shorted;
- ERR3:** The hot bed exceeds the minimum temperature limit, please check whether the thermal interface is disconnected;
- ERR4:** The nozzle exceeds the minimum temperature limit, please check whether the thermal interface is disconnected;
- ERR5:** The heating of the nozzle fails. If the nozzle does not reach the set temperature difference within the set time, an error will be reported; please check the configuration file settings or check whether the power supply is sufficient;
- ERR6:** The heating of the heating bed fails. If the heating bed reaches the set temperature difference within the set time, an error will be reported; please check the configuration file settings or check whether the power supply is sufficient;
- ERR7:** Thermal runaway; when the temperature reaches the target temperature, the current temperature is lower than the target temperature value within the set time and exceeds the set temperature, an error will be reported; please check whether the thermal sensitivity is normal or whether the PID value is appropriate.

FAQ CATALOG

(Summary of Question&Answer)

1. Q&A of Screen	18
2. Q&A of Motor	19
3. Q&A of SD Card	20
4. Q&A of Extruder	21
5. Q&A of Heat Bed	22
6. Q&A of Printing	22

1. Q&A of Screen

1.1 When the screen turns white : 1. pls check if the screen cable is loose and re-tighten.

1.2 (Place of screen connection)

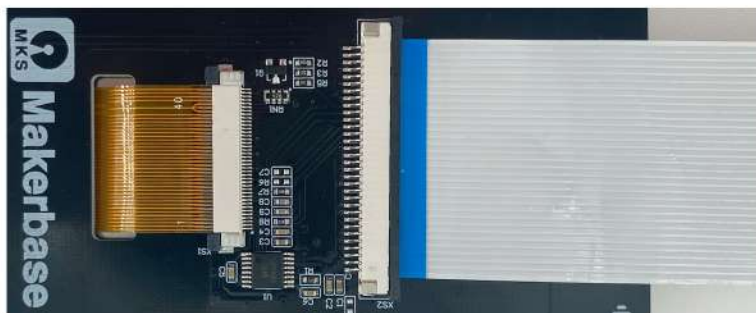

(Place of motherboard connection)

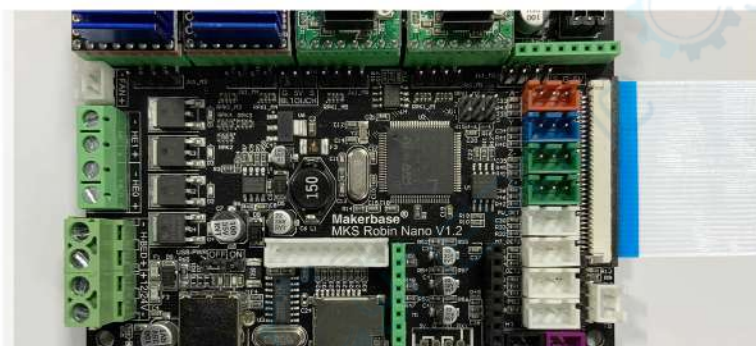

1.3 The screen line is loose: There will be a vibration during the transportation of the machine. The vibration may cause the wire plug inside the machine to loosen and cause poor contact or no contact. At this time, the screen of the machine will turn white and not work properly. Pls check if the line have problems firstly.

1.4 Motherboard or screen problem: If there is no problem with the screen line, then there is a problem with the motherboard or the screen. If there are multiple machines, you can replace the "bad" with a normally displayed screen. If the good screen can be displayed normally, it is a problem with the original screen, if not, there is a problem with the motherboard. If you encounter this problem, you can contact the after-sales customer service.

1.5 Pls make sure if there is any high frequency interference nearby? High frequency interference will cause the screen to be white.

2. Q&A of Motor

If the motor has a jitter fault, or there is no response after plugging in the power.

2.1 First check whether the motor wire and the motor terminal or the motherboard port are firmly connected. If there is looseness or poor contact, and the power can be tested after re-plugging.

2.2 Exchange the positions of the motors. If there is no response after re-plugging, the problematic motor and the normal motor can be exchanged at the motherboard port for testing. After the test, the motor fault is judged. (A. Motor line Problem B. Drive problem C. Motor problem)

A. Motor line problem: After confirming that the motor is ok, please exchange positions of the problematic line on the main board and the motor with the motor line that has no problem, and then test it. If there is no problem, then it is the problem of the motor line. If it still doesn't work, pls check the driver.

Note: Adjust the motor wiring on the main board. As shown in the figure, if it is Y-axis jitter, you can exchange the bad motor line and the good motor line (Y/XZ/E-axis motor line are ok) ports. At the same time, it is necessary to match the motor line to the corresponding motor. After power-on, test it by testing the function of the moving shaft.

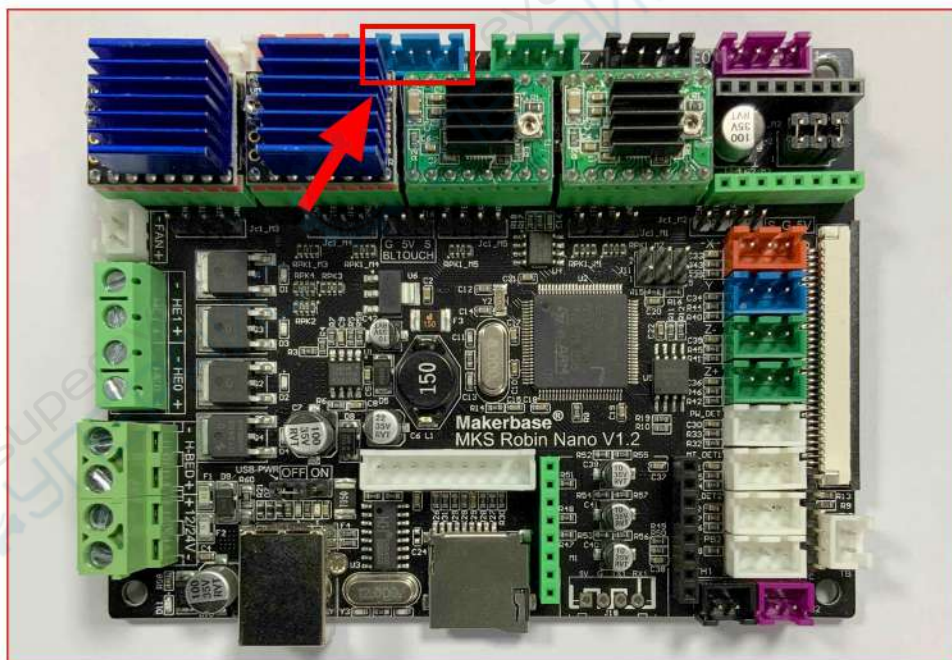

B. Drive problem: Under the premise of confirming that the motor and the motor line are no problem, check the motor drive again. There may be a problem with the drive and a new drive needs to be replaced.

3. Q&A of SD Card

The card slot does not read the card and check if the SD card is broken

4.1 SD card problem: How to determine if there is any problem with the SD card, first check whether the card can be used normally on the computer. If the SD card can be used normally on the computer, first save the file to the computer and format the card at the same time. After the card is put on the machine and tested, if it is not recognized after the power-on-test, it proves that the SD card has a problem and needs to be replaced.

4.2 Check if the card slot is loose

Card slot problem: Long-term use of the card slot may cause the card holder to shake, resulting in poor card reading, and need to replace the new card holder to solve the problem. Sometimes the card may be inserted into the card for a moment and then suddenly no response. You can quickly plug in and out several times and then try to plug in after turning off the power, then take some alcohol to clean it on the card, then insert the card into the card slot, and then insert it several times to see if it can be used normally after cleaning.

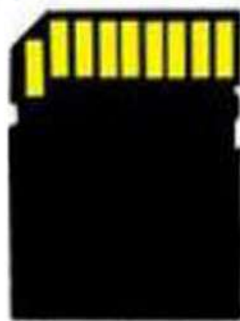
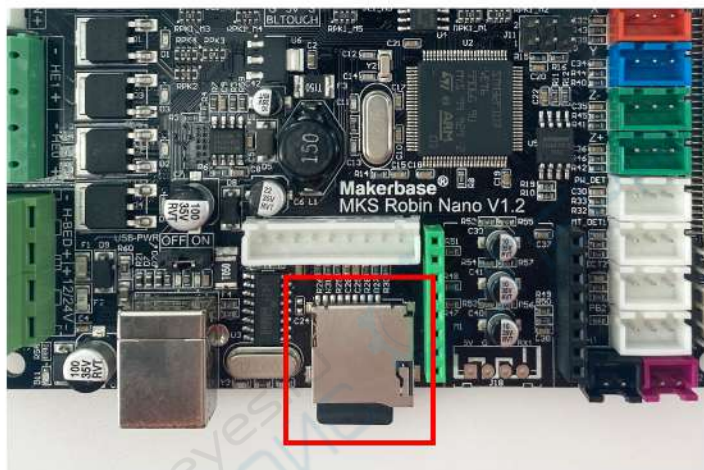

SD Card

4.3 SD card chip oxidation, you can try to apply a little alcohol on the SD card, and then insert the card into the card slot, insert a few more times, see if it can be used normally after cleaning.

4. Q&A of Extruder

- 3.1 The motor of the extruder does not work. It may be damaged by the motor or the motor is poorly connected. It is necessary to check the fault and then go on the power-on test.
- 3.2 It is difficult to extrude the material after heating, and the nozzle is clogged and the discharge is abnormal. It is necessary to replace the nozzle or use the cleaning needle to clean the residual material of the nozzle to ensure the smooth flow of the nozzle.
- 3.3 The nozzle temperature is abnormally heated, which may be caused by damage to the thermistor of the hot bed. The normal display temperature is about plus or minus 2 degrees of the set temperature. You can check whether the thermistor on the heating block is off or the connection port of the main board is not well connected.

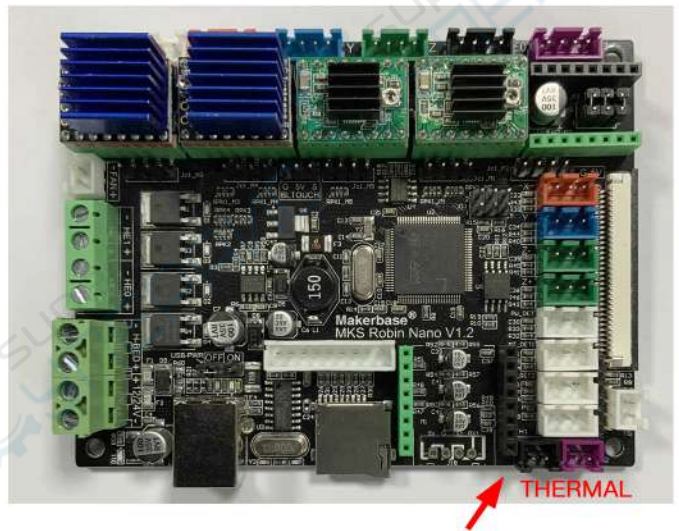

3.4 Q&A of Motherboard

If the new heating kit is replaced and it does not heat properly, it may be a motherboard problem. First check the heating tube line. If it is not possible, you can test the output voltage of the two ports of the motherboard heating tube. Normally, it is 24v. If there is no output voltage, it may be a problem with the motherboard. At this time, you need to repair the motherboard to solve the problem.

5. Q&A of Heat Bed

- 5.1 The temperature of the hot bed is abnormal, which may be caused by the damage of the thermistor of the hot bed. The normal display temperature is about plus or minus 2 degrees of the set temperature. You can check whether the thermistor on the hot bed is off or the connection port of the main board is not in good contact. as the picture shows.

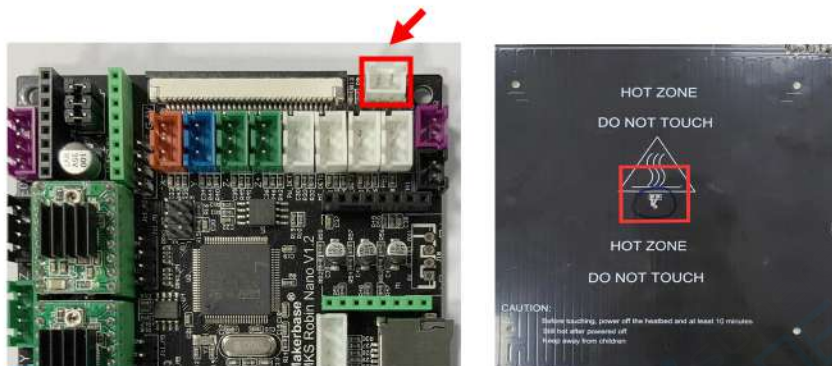

6. Q&A of Printing

6.1 Misprint

- A. The drive heat sink is not attached – paste the heat sink to the drive
- B. Motor drive overheating – keep the drive's heat dissipation good
- C. Motor drive current is too large – readjust the appropriate drive current
- D. Motor synchronous wheel is not fixed – retighten the synchronous wheel
- E. Optical axis Slider Screw stuck – Manually adjust to a smooth position after oiling
- F. X Y-axis belt is too slack – re-adjust the belt tension

6.2 X Y Z axis direction cannot be reset

- A. Limit switch failure – replace the limit switch
- B. Cannot return to zero after printing is complete – wrong axis direction
- C. Home and motion speed is too slow – motor drive pulse setting is incorrect

6.3 Print file is not recognized

- A. The SD file cannot be recognized after the SD card is inserted – the file code is incorrect and the code needs to be renamed
- B. Top printing after half of the print—Slice problem or poor SD card contact

6.4 Printer abnormal sound

- A. Fan problem – there may be abnormal noise caused by the fan blade touching the outer casing
- B. Structural problems – abnormal operation of the T8 screw and slider causes the sound to be too loud, re-oiling and correcting the direction
- C. Belt problem – abnormal sound caused by belt shedding and misalignment

MOTHERBOARD INSTALLATION METHOD

1. Connect the hotbed power cord to the "hotbed connector".
2. Connect the hot bed thermistor wire to Hot Bed Heat.
3. Connect the X.Y-Endstop switch cable to the "X.Y limit switch".
4. Connect the Z-Endstop switch cable to the "Z Endstop connector".
(Or use automatic induction switch)
5. Connect the X.Y.E motor cable to the "X.Y.E motor".
6. Connect the radiator cooling fan wire to "12V / 24V rated output".
7. Connect the print model cooling fan wires to the Fan Connector.
8. Connect the hot end heating rod to the "Extrusion Head 1 Port".
9. Connect the hot-end thermistor to "Extrusion head 1".
10. Connect the filament sensor to "Break Detection 1".

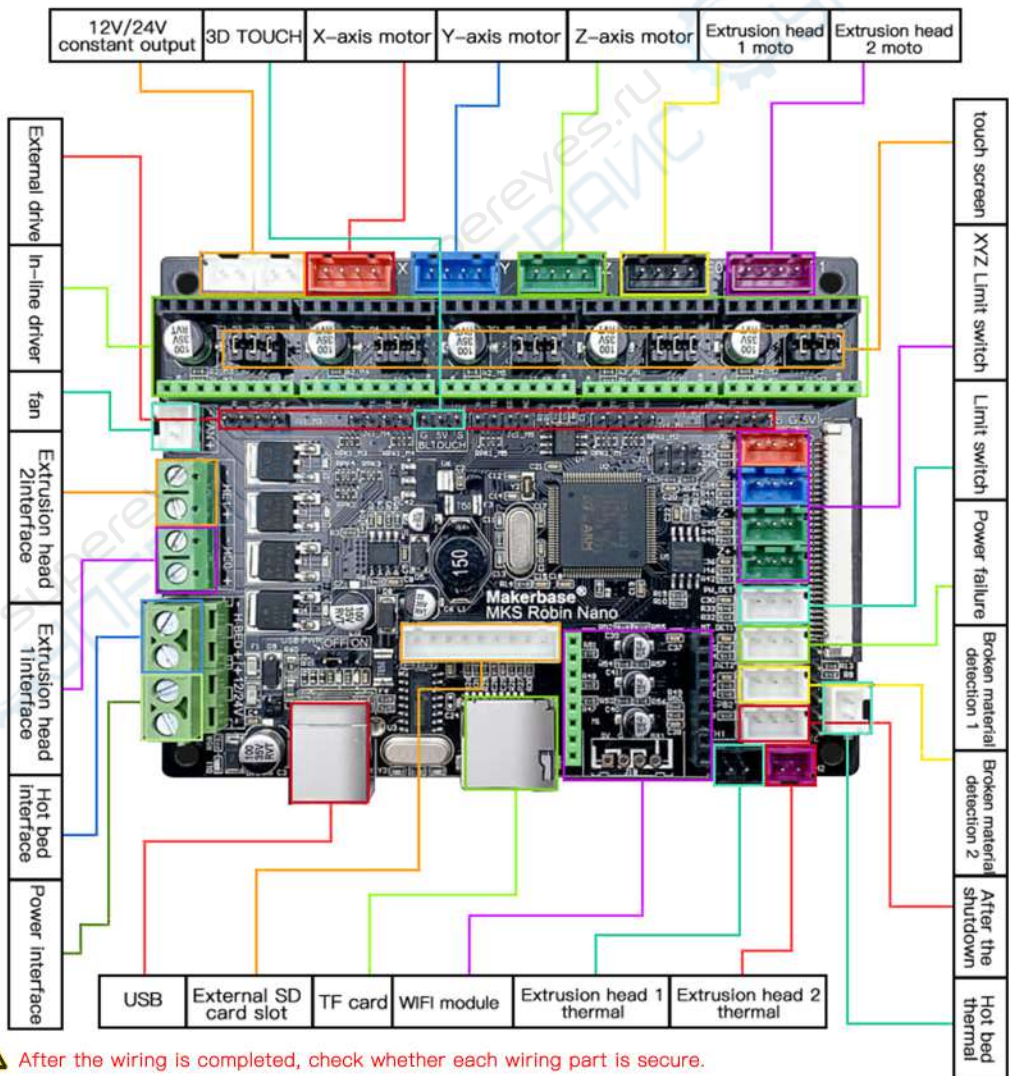

! After the wiring is completed, check whether each wiring part is secure.

DRIVER DESCRIPTION

Drive current algorithm and adjustment

1. Vref measures Gnd and the intermediate voltage of the potentiometer. Turn the potentiometer clockwise to decrease the current and counterclockwise to increase it.
2. Be sure not to connect the motor when measuring the voltage, otherwise it will burn the drive easily.
3. Turn on the power when measuring the voltage, do not just connect the USB power supply.
4. Please pay special attention to the direction, do not insert the reverse.

$I = V_{ref}$ default current $I = 1.25A$

Default current: 1.25a

Maximum current: 2.5a

Logic voltage: 3.5v/5v

Input voltage: 5.5v/28v

Breakdown: up to 1/256

Mode: dir/step, uart

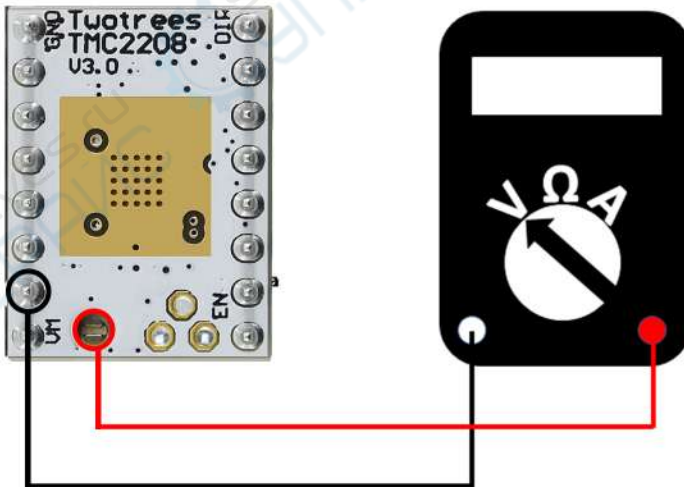

AFTER-SALES SERVICE

The shelf life is 12 months from the date of purchase.

1. Missing / damaged / defective parts
 - a. Within 7 days after the delivery date, we will replace any parts for free, including shipping costs.
 - b. 7 days after the delivery date, we will replace any parts for free. But customers need to pay the freight.
2. Customer damaged parts: The customer should pay for the parts cost and transportation costs.
3. The courier company lost, lost, damaged and defective parts.
 - a. Claims for lost or damaged goods must be reported to the carrier within the carrier's claim window, The customer needs to notify us within 7 days after the delivery date.
 - b. For any parts lost or damaged during transportation, the customer should take photos or videos and Send us the information.
 - c. Once the carrier dispute is resolved, please provide us with all communications with the carrier. The customer is responsible
Let us keep abreast of all correspondence with the carrier.
 - d. For missing parts, the customer should fill in the service order.
 - e. For damaged parts, the customer should fill in the service ticket and send the photo or video to us.
 - f. If the component is an LCD panel, power supply or motherboard, the customer should ship the component back to us and we will Send new parts.

LETTER FROM TWOTREES

Dear Customers:

Thank you for choosing the Bluer 3D printer.

These operating instructions will guide you through the installation and first use of the Printer.

If you have any problems with the assembly, please contact us via

Facebook: <https://www.facebook.com/groups/Bluer3DPrinter/>

Website: www.twotrees3dprinter.com

Servicemail: service@twotrees3dprinter.com

Our customer service team will contact you within 48 hours.

Sincerely yours

Two Trees team



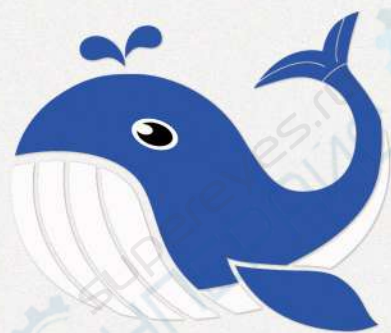

BLUER