

RIGOL

Programming Guide

Vector Network Analyzer

Applicable to RSA5000N/RSA3000N

Jul. 2020
RIGOL TECHNOLOGIES CO., LTD.



Guaranty and Declaration

Copyright

© 2020 **RIGOL** TECHNOLOGIES CO., LTD. All Rights Reserved.

Trademark Information

RIGOL® is the trademark of **RIGOL** TECHNOLOGIES CO., LTD.

Publication Number

PGD24100-1110

Software Version

00.03.00

Software upgrade might change or add product features. Please acquire the latest version of the manual from **RIGOL** website or contact **RIGOL** to upgrade the software.

Notices

- **RIGOL** products are covered by P.R.C. and foreign patents, issued and pending.
- **RIGOL** reserves the right to modify or change parts of or all the specifications and pricing policies at the company's sole decision.
- Information in this publication replaces all previously released materials.
- Information in this publication is subject to change without notice.
- **RIGOL** shall not be liable for either incidental or consequential losses in connection with the furnishing, use, or performance of this manual, as well as any information contained.
- Any part of this document is forbidden to be copied, photocopied, or rearranged without prior written approval of **RIGOL**.

Product Certification

RIGOL guarantees that this product conforms to the national and industrial standards in China as well as the ISO9001:2015 standard and the ISO14001:2015 standard. Other international standard conformance certifications are in progress.

Contact Us

If you have any problem or requirement when using our products or this manual, please contact **RIGOL**.

Document Overview

This manual introduces how to program and control **RIGOL** RSA series spectrum analyzer (EMI mode) by using SCPI commands through USB and LAN interface.

Main Topics of this Manual:

Chapter 1 Programming Overview

This chapter introduces how to set up remote communication between the spectrum analyzer and the PC, the remote control methods, the syntax, symbols, parameters, and abbreviation rules of the SCPI commands.

Chapter 2 Command System

This chapter introduces the syntax, function, parameters, and usage of each command in EMI mode for the RSA series.

Tip

For the latest version of this manual, download it from the official website of **RIGOL** (www.rigol.com).

Format Conventions in this Manual:

1. Keys:

The keys on the front panel are usually denoted by the format of "Key Name (Bold) + Text Box". For example, **FREQ** denotes the **FREQ** key.

2. Menu keys:

The menu softkeys are usually denoted by the format of "Menu Word (Bold) + Character Shading". For example, **Center Freq** denotes the midspan frequency menu item under the **FREQ** function key.

3. Connectors:

The connectors at the front or rear panel are usually denoted by the format of "Connector name (Bold) + square brackets (Bold)". For example, **[Gen Output 50Ω]**.

4. Operation Procedures:

"→" represents the next step of operation. For example, **FREQ** → **Center Freq** indicates pressing **FREQ** on the front panel and then pressing the menu softkey **Center Freq**.

Content Conventions in this Manual:

The RSA series spectrum analyzer that supports the VNA mode includes the following models. This manual takes RSA5065N as an example.

Model	Frequency Range	VNA Frequency Range
RSA5065N	9 kHz to 6.5 GHz	100 kHz to 6.5 GHz
RSA5032N	9 kHz to 3.2 GHz	100 kHz to 3.2 GHz
RSA3045N	9 kHz to 4.5 GHz	100 kHz to 4.5 GHz
RSA3030N	9 kHz to 3 GHz	100 kHz to 3 GHz
RSA3015N	9 kHz to 1.5 GHz	100 kHz to 1.5 GHz

Contents

Guaranty and Declaration	1
Document Overview	II
Chapter 1 Programming Overview.....	1-1
Build Remote Communication	1-2
Remote Control Method	1-3
SCPI Command Overview	1-4
Syntax.....	1-4
Symbol Description	1-4
Parameter Type.....	1-5
Command Abbreviation	1-5
Chapter 2 Command System.....	2-1
:CALCulate Commands.....	2-2
:CALCulate:MARKer:AOFF	2-2
:CALCulate:MARKer:CURRent:AOFF	2-2
:CALCulate:MARKer:TABLE:[STATe]	2-3
:CALCulate:MARKer<n>:CPSearch[:STATe]	2-3
:CALCulate:MARKer<n>:LINEs:[STATe]	2-4
:CALCulate:MARKer<n>:MAXimum[:MAX]	2-4
:CALCulate:MARKer<n>:MAXimum:LEFT	2-4
:CALCulate:MARKer<n>:MAXimum:NEXT	2-5
:CALCulate:MARKer<n>:MAXimum:RIGHT	2-5
:CALCulate:MARKer<n>:MINimum	2-6
:CALCulate:MARKer<n>:MODE	2-6
:CALCulate:MARKer<n>:REFerence.....	2-7
:CALCulate:MARKer<n>[:SET]:CENTer	2-7
:CALCulate:MARKer<n>[:SET]:RLEVel.....	2-8
:CALCulate:MARKer<n>[:SET]:START.....	2-8
:CALCulate:MARKer<n>[:SET]:STOP.....	2-8
:CALCulate:MARKer<n>:X	2-9
:CALCulate:MARKer<n>:Y	2-9
:CALCulate:TRACe:GDELay:APERture	2-10
:CALCulate:TRACe<n>:MATH:MEMorize	2-10
:CALibration Commands	2-11
:CALibration:CKIT:C0.....	2-11
:CALibration:CKIT:C1.....	2-12
:CALibration:CKIT:C2.....	2-12
:CALibration:CKIT:C3.....	2-13
:CALibration:CKIT:L0	2-13
:CALibration:CKIT:L1	2-14
:CALibration:CKIT:L2	2-14
:CALibration:CKIT:L3	2-15
:CALibration:CKIT:LABel	2-15
:CALibration:CKIT:LENGth.....	2-16
:CALibration:CKIT:LOSS.....	2-16
:CALibration:CKIT:TYPE	2-17
:CALibration:CKIT:Z0.....	2-17
:CALibration:CLEAr	2-18
:CALibration:DTF:ABORT.....	2-18
:CALibration:DTF:LOAD	2-18
:CALibration:DTF:OPEN	2-18
:CALibration:DTF:SAVE	2-18
:CALibration:DTF:SHORT.....	2-19
:CALibration:S11:ABORT	2-19

:CALibration:S11:LOAD	2-19
:CALibration:S11:OPEN	2-19
:CALibration:S11:SAVE.....	2-19
:CALibration:S11:SHORT.....	2-19
:CALibration:S21:ABORT.....	2-20
:CALibration:S21:SAVE.....	2-20
:CALibration:S21:THROUGH	2-20
:CONFigure Commands	2-21
:CONFigure	2-21
:CONFigure?.....	错误!未定义书签。
:DISPlay Commands.....	2-22
:DISPlay:TRACe<n>:FORMat	2-23
:DISPlay:TRACe<n>:SOURce	2-24
:DISPlay:TRACe<n>:Y[:SCALe]:AUTO	2-24
:DISPlay:TRACe<n>:Y[:SCALe]:PDIVision.....	2-24
:DISPlay:TRACe<n>:Y[:SCALe]:RLEVel.....	2-25
:DISPlay:TRACe<n>:Y[:SCALe]:RPOStion	2-26
:DISPlay:TRACe:Y[:SCALe]:AUTO:ALL	2-26
:DISPlay:WINDow:FORMat	2-27
:DISPlay:WINDow:SElect	2-27
:DISPlay:WINDow:TRACe:Y[:SCALe]:RLEVel	2-28
IEEE 488.2 Common Commands	2-29
*CLS.....	2-30
*ESE.....	2-30
*ESR?.....	2-30
*IDN?.....	2-31
*OPC.....	2-31
*RCL	2-31
*RST	2-32
*SAV	2-32
*SRE	2-32
*STB?.....	2-33
*TRG.....	2-33
*TST?.....	2-33
*WAI	2-33
:INITiate Commands	2-34
:INITiate:CONTinuous	2-34
:INITiate:IMMediate	2-34
:INSTrument Commands.....	2-35
:INSTrument[:SElect].....	2-35
:INSTrument:NSElect	2-35
:MMEMory Commands	2-36
:MMEMory:DElete	2-37
:MMEMory:LOAD:STATe	2-37
:MMEMory:LOAD:TRACe	2-37
:MMEMory:STORE:SCReen	2-38
:MMEMory:STORE:STATe.....	2-38
:MMEMory:STORE:TRACe.....	2-39
:OUTPut Command	2-40
:OUTPut[:EXtErnal][:STATe]?	2-40
[[:SENSe] Commands	2-41
:INPut:IMPedance	2-55
[:SENSe]:CORRection:IMPedance[:INPut][:MAGNitude]	2-55
[:SENSe]:AVERAge:COUNT	2-42
[:SENSe]:BANDwidth BWIDth[:RESolution]	2-42
[:SENSe]:BANDwidth BWIDth:SHAPE.....	2-43
[:SENSe]:CALibration:DTF:DISTance:STOP	2-43

[:SENSe]:CALibration:DTF:LENGth:UNIT	2-44
[:SENSe]:CALibration:DTF:LOSS:COAX	2-44
[:SENSe]:CALibration:DTF:VELocity	2-45
[:SENSe]:CALibration:EXTension:S11:LENGth:UNIT	2-45
[:SENSe]:CALibration:EXTension:S11:PORT1:LENGth	2-48
[:SENSe]:CALibration:EXTension:S11:PORT1:LOSS:COAX	2-49
[:SENSe]:CALibration:EXTension:S11:PORT1:TIME	2-49
[:SENSe]:CALibration:EXTension:S11:PORT1:VELocity	2-50
[:SENSe]:CALibration:EXTension:S11:STATe	2-50
[:SENSe]:CALibration:EXTension:S21:LENGth:UNIT	2-51
[:SENSe]:CALibration:EXTension:S21:PORT1:LENGth	2-51
[:SENSe]:CALibration:EXTension:S21:PORT1:LOSS:COAX	2-52
[:SENSe]:CALibration:EXTension:S21:PORT1:TIME	2-52
[:SENSe]:CALibration:EXTension:S21:PORT1:VELocity	2-53
[:SENSe]:CALibration:EXTension:S21:PORT2:LENGth	2-53
[:SENSe]:CALibration:EXTension:S21:PORT2:LOSS:COAX	2-54
[:SENSe]:CALibration:EXTension:S21:PORT2:TIME	2-54
[:SENSe]:CALibration:EXTension:S21:PORT2:VELocity	2-55
[:SENSe]:CALibration:EXTension:S21:STATe	2-55
[:SENSe]:CALibration:EXTension:DTF:LENGth:UNIT	2-45
[:SENSe]:CALibration:EXTension:DTF:PORT1:LENGth	2-45
[:SENSe]:CALibration:EXTension:DTF:PORT1:LOSS:COAX	2-46
[:SENSe]:CALibration:EXTension:DTF:PORT1:TIME	2-46
[:SENSe]:CALibration:EXTension:DTF:PORT1:VELocity	2-47
[:SENSe]:CALibration:EXTension:DTF:STATe	2-47
[:SENSe]:FREQuency:CENTer	2-55
[:SENSe]:FREQuency:CENTer:STEP:AUTO	2-57
[:SENSe]:FREQuency:CENTer:STEP[:INCRement]	2-57
[:SENSe]:FREQuency:SPAN	2-58
[:SENSe]:FREQuency:SPAN:FULL	2-58
[:SENSe]:FREQuency:START	2-58
[:SENSe]:FREQuency:STOP	2-59
[:SENSe]:SWEep:POINts	2-60
[:SENSe]:SWEep:TIME	2-60
[:SENSe]:SWEep:TIME:AUTO	2-61
:SOURce Commands	2-62
:SOURce[:EXTErnal]:POWEr[:LEVel][:IMMEDIATE][:AMPLitude]	2-62
:STATus Commands	2-63
:STATus:OPERation:CONDition?	2-64
:STATus:OPERation:ENABle	2-64
:STATus:OPERation[:EVENT]?	2-65
:STATus:PRESet	2-65
:STATus:QUESTionable:CONDition?	2-65
:STATus:QUESTionable:ENABle	2-65
:STATus:QUESTionable[:EVENT]?	2-66
:SYSTem Commands	2-67
:SYSTem:BEEPer:STATe	2-68
:SYSTem:COMMunicate:LAN[:SELF]:APPLY	2-68
:SYSTem:COMMunicate:LAN[:SELF]:AUTOip:STATe	2-68
:SYSTem:COMMunicate:LAN[:SELF]:DHCP:STATe	2-69
:SYSTem:COMMunicate:LAN[:SELF]:IP:ADDREss	2-69
:SYSTem:COMMunicate:LAN[:SELF]:IP:DNSBack	2-70
:SYSTem:COMMunicate:LAN[:SELF]:IP:DNSPreferred	2-70
:SYSTem:COMMunicate:LAN[:SELF]:IP:DNSServer	2-70
:SYSTem:COMMunicate:LAN[:SELF]:IP:GATEway	2-71
:SYSTem:COMMunicate:LAN[:SELF]:IP:SUBMask	2-72
:SYSTem:COMMunicate:LAN[:SELF]:MANuip:STATe	2-72
:SYSTem:COMMunicate:LAN[:SELF]:MDNS:STATe	2-73

:SYSTem:COMMunicate:LAN[:SELF]:RESet	2-73
:SYSTem:CONFigure:INFormation?	2-73
:SYSTem:DATE	2-74
:SYSTem:FSWitch[:STATE]	2-74
:SYSTem:LANGUage.....	2-75
:SYSTem:LKEY	2-75
:SYSTem:OPTion:STATE?.....	2-76
:SYSTem:PON:TYPE.....	2-76
:SYSTem:PRESet	2-77
:SYSTem:PRESet:SAVE.....	2-77
:SYSTem:PRESet:TYPE.....	2-77
:SYSTem:PRESet:USER:SAVE	2-77
:SYSTem:SCPI:DISPlay	2-78
:SYSTem:SECurity:CLEar	2-78
:SYSTem:SHOW	2-78
:SYSTem:TIME	2-79
:TRACe Commands	2-80
:TRACe<n>:DATA?.....	2-80
:TRACe<n>:DATA:MEMory?	2-80
:TRACe<n>:MATH:TYPE	2-81
:TRACe<n>:MODE	2-81
:TRACe<n>:TYPE.....	2-81
:TRACe<n>:UPDate:STATE	2-82
:TRIGger Commands.....	2-83
:TRIGger[:SEquence]:ATRigger.....	2-83
:TRIGger[:SEquence]:ATRigger:STATE.....	2-83
:TRIGger[:SEquence]:EXTernal<n>:DELay	2-84
:TRIGger[:SEquence]:EXTernal<n>:DELay:STATE	2-84
:TRIGger[:SEquence]:EXTernal<n>:SLOPe.....	2-85
:TRIGger[:SEquence]:HOLDoff	2-86
:TRIGger[:SEquence]:HOLDoff:STATE	2-86
:TRIGger[:SEquence]:SOURce	2-87
:TRIGger2:MODE	2-87
Chapter 3 Appendix.....	3-1
Appendix A: Default Settings	3-1
Appendix B: Warranty.....	3-4

Chapter 1 Programming Overview

This chapter introduces how to set up remote communication between the spectrum analyzer and the PC, the remote control methods, the syntax, symbols, parameters, and abbreviation rules of the SCPI commands.

Contents in this chapter:

- ◆ [Build Remote Communication](#)
- ◆ [Remote Control Method](#)
- ◆ [SCPI Command Overview](#)

Build Remote Communication

The RSA series spectrum analyzer can be connected to the PC via the USB or LAN interface to set up communication and realize remote control through the PC. This Chapter introduces in details how to use Ultra Sigma to send commands through the USB interface to control the analyzer.

Operation Procedures:

1. Install Ultra Sigma (PC) software.

You can download Ultra Sigma from the official website of **RIGOL** (www.rigol.com) and install the software according to the installation wizard.

2. Connect the analyzer to the PC and configure the interface parameters for the instrument

RSA supports the USB and LAN interfaces.

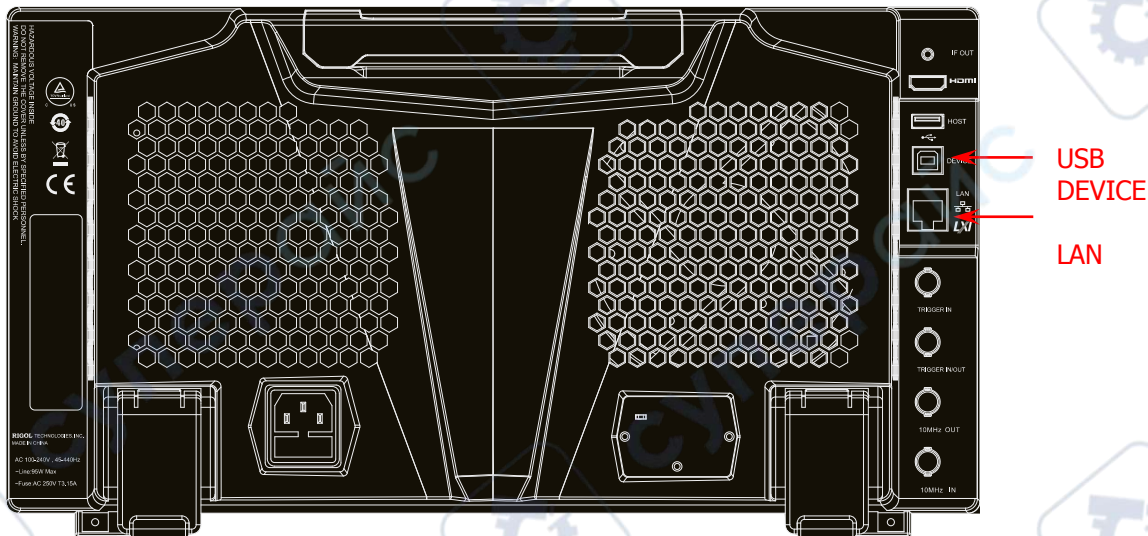

Figure 1-1 RSA5000 Communication Interface

(1) Remote communication via USB:

Use the USB cable to connect the rear-panel USB DEVICE interface of RSA5000 to the USB HOST interface of the PC.

(2) Use the LAN interface:

- Make sure that your PC has been accessed to the local area network.
- Check whether the local area network where your PC resides supports DHCP or auto IP mode. If not, you need to obtain the available network interface parameters, including the IP address, subnet mask, default gateway, and DNS.
- Connect RSA5000 to the local area network by using the network cable.
- Press **System** → **Interface** → **LAN** to configure the IP address, subnet mask, default gateway, and DNS for the instrument.

3. Check whether the connection is successful

Run Ultra Sigma. Search the resource and right-click the resource name. In the displayed menu, select "SCPI Panel Control". In the SCPI command control panel, input a correct command. After that, click **Send Command** first and then click **Read Response**. Or you can also directly click **Send & Read** to verify whether the connection works properly. The following figure takes USB interface as an example to illustrate it.

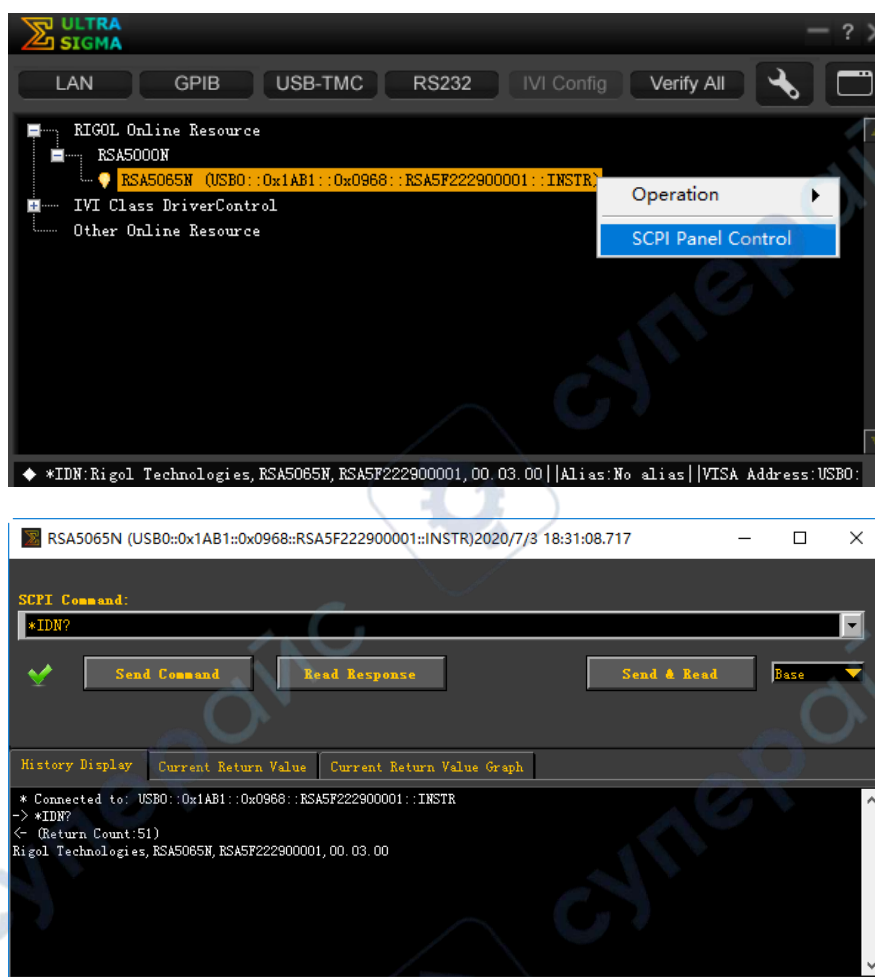

Remote Control Method

1. User-defined programming

You can refer to the SCPI (Standard Commands for Programmable Instruments) commands listed in Chapter 2 in this manual to control RSA by programming in LabVIEW, Visual C++, and other development environments. For details, refer to descriptions in Chapter 3 in *RSA5000 Programming Guide* and *RSA3000 Programming Guide*.

2. Send SCPI commands via the PC software

You can use the PC software to send commands to control RSA remotely. **RIGOL** Ultra Sigma is recommended. You can download the software from **RIGOL** official website (www.rigol.com).

SCPI Command Overview

SCPI (Standard Commands for Programmable Instruments) is a standardized instrument programming language that is built upon the existing standard IEEE 488.1 and IEEE 488.2 and conforms to various standards, such as the floating point operation rule in IEEE 754 standard, ISO 646 7-bit coded character set for information interchange (equivalent to ASCII programming). This chapter introduces the syntax, symbols, parameters, and abbreviation rules of the SCPI commands.

Syntax

The SCPI commands provide a hierarchical tree structure, and consist of multiple subsystems. Each command subsystem consists of one root keyword and one or more sub-keywords. The command line usually starts with ":"; the keywords are separated by ":" and are followed by the parameter settings available; "?" is added at the end of the command line to indicate a query; the commands and parameters are separated by space.

For example,

```
:SOURce:CORRection:OFFSet <rel_ampl>  
:SOURce:CORRection:OFFSet?
```

SOURce is the root keyword of the command. CORRection is the second-level keyword, and OFFSet is the third-level keyword. The command line starts with ":", and a colon is also used to separate the multiple-level keywords. <rel_ampl> represents the parameters available for setting. "?" represents query. The command :SOURce:CORRection:OFFSet and the parameter <rel_ampl> are separated by a space.

In some commands with parameters, "," is often used to separate each parameter. For example,
:SYSTem:DATE <year>,<month>,<day>.

Symbol Description

The following four symbols are not part of the SCPI command, and they are not sent with the commands, but taken as delimiters to better describe the parameters in the command.

1. Braces { }

The parameters enclosed in the braces are optional. You do not have to set it, also you can set for one or more times.

2. Vertical Bar |

The vertical bar is used to separate multiple parameters. When using the command, you must select one of the parameters. For example,
In the command :CALCulate:MARKer<n>:LINes:STATe OFF|ON|0|1, you can select any of the four available parameters: OFF, ON, 0, or 1.

3. Square Brackets []

The contents (command keywords) in the square brackets can be omitted. If the keyword is omitted, it will be set to the default. For example,
for the :SENSe:CORRection:IMPedance[:INPut][:MAGNitude]? command, sending any of the four commands below can generate the same effect:

```
:SENSe:CORRection:IMPedance?  
:SENSe:CORRection:IMPedance:INPut?  
:SENSe:CORRection:IMPedance:MAGNitude?  
:SENSe:CORRection:IMPedance:INPut:MAGNitude?
```

4. Angle Brackets < >

When sending the command, the parameter enclosed in the angle-bracket must contain an effective

value. For example, send the :CALCulate:MARKer2:REFerence 3 command to validate the :CALCulate:MARKer<n>:REFerence <integer> command.

Parameter Type

The command parameters introduced in this manual include 6 types: Bool, Keyword, Integer, Consecutive Real Number, Discrete, and ASCII String.

1. Bool

The parameter can be set to OFF (0) or ON (1).

2. Keyword

The parameter can be any of the values listed.

3. Integer

Unless otherwise specified, the parameter can be any integer within the effective value range. Note: Do not set the parameter to a decimal, otherwise, errors will occur.

4. Consecutive Real Number

Unless otherwise specified, the parameter could be any value within the effective value range according to the accuracy requirement (by default, there are 9 digits after the decimal points).

5. Discrete

The parameter could only be one of the specified values and these values are discontinuous.

6. ASCII String

The parameter can be the combinations of ASCII characters.

Command Abbreviation

All the commands are case-insensitive. They can all be written in upper case or in lower case. For abbreviations, you only need to input all the upper-case letters in the command. For example, :SOURce:CORRection:OFFSet? can be abbreviated as :SOUR:CORR:OFFS? or :sour:corr:offs?



Chapter 2 Command System

This chapter introduces the commands of the RSA series spectrum analyzer in EMI mode.

Contents in this chapter:

- ◆ [:CALCulate Commands](#)
- ◆ [:CALibration Commands](#)
- ◆ [:CONFigure Command](#)
- ◆ [:DISPlay Commands](#)
- ◆ [IEEE 488.2 Common Commands](#)
- ◆ [:INITiate Commands](#)
- ◆ [:INSTrument Commands](#)
- ◆ [:MMEMory Commands](#)
- ◆ [:OUTPut Command](#)
- ◆ [\[:SENSe\] Commands](#)
- ◆ [:SOURce Commands](#)
- ◆ [:STATus Commands](#)
- ◆ [:SYSTem Commands](#)
- ◆ [:TRACe Commands](#)
- ◆ [:TRIGger Commands](#)

Remarks:

1. For the command set, unless otherwise specified, the query command returns "N/A" (without quotations in its return format) if no specified option is installed. If the queried function is disabled or improper type match is found, the query command will return "error" (without quotations in its return format).
2. This manual takes RSA5065N as an example to illustrate the range of the parameters in each command.

:CALCulate Commands

Command List:

- ◆ [:CALCulate:MARKer:AOff](#)
- ◆ [:CALCulate:MARKer:CURRent:AOff](#)
- ◆ [:CALCulate:MARKer:TABLE:\[STATe\]](#)
- ◆ [:CALCulate:MARKer<n>:CPSeArch\[:STATe\]](#)
- ◆ [:CALCulate:MARKer<n>:LINEs:\[STATe\]](#)
- ◆ [:CALCulate:MARKer<n>:MAXimum\[:MAX\]](#)
- ◆ [:CALCulate:MARKer<n>:MAXimum:LEFT](#)
- ◆ [:CALCulate:MARKer<n>:MAXimum:NEXT](#)
- ◆ [:CALCulate:MARKer<n>:MAXimum:RIGHT](#)
- ◆ [:CALCulate:MARKer<n>:MINimum](#)
- ◆ [:CALCulate:MARKer<n>:MODE](#)
- ◆ [:CALCulate:MARKer<n>:REFerence](#)
- ◆ [:CALCulate:MARKer<n>\[:SET\]:CENTer](#)
- ◆ [:CALCulate:MARKer<n>\[:SET\]:RLEVEL](#)
- ◆ [:CALCulate:MARKer<n>\[:SET\]:START](#)
- ◆ [:CALCulate:MARKer<n>\[:SET\]:STOP](#)
- ◆ [:CALCulate:MARKer<n>:X](#)
- ◆ [:CALCulate:MARKer<n>:Y](#)
- ◆ [:CALCulate:TRACe:GDELay:APERture](#)
- ◆ [:CALCulate:TRACe<n>:MATH:MEMorize](#)

:CALCulate:MARKer:AOff

Syntax

:CALCulate:MARKer:AOff

Description

Turns off all the enabled markers.

:CALCulate:MARKer:CURRent:AOff

Syntax

:CALCulate:MARKer:CURRent:AOff

Description

Disables the enabled marker in the current window.

:CALCulate:MARKer:TABLE:[STATe]**Syntax**

:CALCulate:MARKer:TABLE:[STATe] OFF|ON|0|1
 :CALCulate:MARKer:TABLE:[STATe]?

Description

Enables or disables the marker table.
 Queries the on/off status of the marker table.

Parameter

Name	Type	Range	Default
--	Bool	OFF ON 0 1	OFF 0

Return Format

The query returns 0 or 1.

Example

The following command disables the marker table.
 :CALCulate:MARKer:TABLE:STATe OFF or :CALCulate:MARKer:TABLE:STATe 0

The following query returns 0.
 :CALCulate:MARKer:TABLE:STATe?

:CALCulate:MARKer<n>:CPSearch[:STATe]**Syntax**

:CALCulate:MARKer<n>:CPSearch[:STATe] OFF|ON|0|1
 :CALCulate:MARKer<n>:CPSearch[:STATe]?

Description

Enables or disables continuous peak search function and marks the peak value.
 Queries the on/off status of the continuous peak search function.

Parameter

Name	Type	Range	Default
<n>	Discrete	1 2 3 4 5 6 7 8	--
--	Bool	OFF ON 0 1	OFF 0

Return Format

The query returns 0 or 1.

Example

The following command performs the continuous peak search function and marks with Marker 1.
 :CALCulate:MARKer1:CPSearch:STATe ON or :CALCulate:MARKer1:CPSearch:STATe 1

The following query returns 1.
 :CALCulate:MARKer1:CPSearch:STATe?

:CALCulate:MARKer<n>:LINES:[STATE]**Syntax**

```
:CALCulate:MARKer<n>:LINES:[STATE] OFF|ON|0|1
:CALCulate:MARKer<n>:LINES:[STATE]?
```

Description

Enables or disables the marker line of the specified marker for the current trace window. Queries the on/off status for the marker line of the specified marker.

Parameter

Name	Type	Range	Default
<n>	Discrete	1 2 3 4 5 6 7 8	--
--	Bool	OFF ON 0 1	OFF 0

Return Format

The query returns 0 or 1.

Example

The following command disables the marker line of the specified marker for the current trace window.
:CALCulate:MARKer<n>:LINES:STATE OFF or :CALCulate:MARKer<n>:LINES:STATE 0

The following query returns 0.

```
:CALCulate:MARKer<n>:LINES:STATE?
```

:CALCulate:MARKer<n>:MAXimum[:MAX]**Syntax**

```
:CALCulate:MARKer<n>:MAXimum[:MAX]
```

Description

Performs one peak search on the current trace and marks it.

Parameter

Name	Type	Range	Default
<n>	Discrete	1 2 3 4 5 6 7 8	--

Remarks

When no peak is found, a prompt message "No peak found" is displayed on the screen.

Example

The following command performs one peak search, and marks with Marker 2.
:CALCulate:MARKer2:MAXimum:MAX

:CALCulate:MARKer<n>:MAXimum:LEFT**Syntax**

```
:CALCulate:MARKer<n>:MAXimum:LEFT
```

Description

Searches for and marks the nearest peak which is located at the left side of the current peak.

Parameter

Name	Type	Range	Default
<n>	Discrete	1 2 3 4 5 6 7 8	--

Remarks

When no peak is found, a prompt message "No peak found" is displayed on the screen.

Example

The following command performs one left peak search, and marks with Marker 2.

```
:CALCulate:MARKer2:MAXimum:LEFT
```

:CALCulate:MARKer<n>:MAXimum:NEXT**Syntax**

```
:CALCulate:MARKer<n>:MAXimum:NEXT
```

Description

Searches for and marks the peak whose amplitude on the trace is next lower than that of the current peak.

Parameter

Name	Type	Range	Default
<n>	Discrete	1 2 3 4 5 6 7 8	--

Remarks

When no peak is found, a prompt message "No peak found" is displayed on the screen.

Example

The following command performs one next peak search, and marks with Marker 2.

```
:CALCulate:MARKer2:MAXimum:NEXT
```

:CALCulate:MARKer<n>:MAXimum:RIGHT**Syntax**

```
:CALCulate:MARKer<n>:MAXimum:RIGHT
```

Description

Searches for and marks the nearest peak which is located at the right side of the current peak.

Parameter

Name	Type	Range	Default
<n>	Discrete	1 2 3 4 5 6 7 8	--

Remarks

When no peak is found, a prompt message "No peak found" is displayed on the screen.

Example

The following command performs one right peak search, and marks with Marker 2.

```
:CALCulate:MARKer2:MAXimum:RIGHT
```

:CALCulate:MARKer<n>:MINimum

Syntax

```
:CALCulate:MARKer<n>:MINimum
```

Description

Searches for and marks the peak with the minimum amplitude on the trace.

Parameter

Name	Type	Range	Default
<n>	Discrete	1 2 3 4 5 6 7 8	--

Remarks

When no peak is found, a prompt message "No peak found" is displayed on the screen.

Example

The following command performs one minimum search, and marks it with Marker 2.

```
:CALCulate:MARKer2:MINimum
```

:CALCulate:MARKer<n>:MODE

Syntax

```
:CALCulate:MARKer<n>:MODE POSition|DELTA|OFF
:CALCulate:MARKer<n>:MODE?
```

Description

Sets the type of the specified marker in the current trace window.

Queries the type of the specified marker in the current trace window.

Parameter

Name	Type	Range	Default
<n>	Discrete	1 2 3 4 5 6 7 8	--
--	Keyword	POSition DELTA OFF	OFF

Remarks

POSition: indicates the normal marker.

DELTA: indicates difference between two data points.

OFF: turns off the selected marker.

Return Format

The query returns POS, DELT, or OFF.

Example

The following command sets the type of Marker 1 to DELTA.

```
:CALCulate:MARKer1:MODE DELTA
```

The following query returns DELT.

```
:CALCulate:MARKer1:MODE?
```

:CALCulate:MARKer<n>:REFerence**Syntax**

```
:CALCulate:MARKer<n>:REFerence <integer>
:CALCulate:MARKer<n>:REFerence?
```

Description

Sets the reference marker for the specified marker on the current trace.
 Queries the reference marker for the specified marker on the current trace.

Parameter

Name	Type	Range	Default
<n>	Discrete	1 2 3 4 5 6 7 8	--
<integer>	Integer	1 to 8	By default, the reference marker is the marker next to it.

Remarks

Each marker can have another marker to be its reference marker. The default reference marker for Marker 8 is Marker 1.

If the current marker is a Delta marker, the measurement result of the marker will be determined by the reference marker.

Any marker cannot have itself to be the reference marker.

Return Format

The query returns the reference marker for the specified marker on the current trace in integer.

Example

The following command sets the reference marker for the Marker 1 to 2.

```
:CALCulate:MARKer1:REFerence 2
```

The following query returns 2.

```
:CALCulate:MARKer1:REFerence?
```

:CALCulate:MARKer<n>[:SET]:CENTer**Syntax**

```
:CALCulate:MARKer<n>[:SET]:CENTer
```

Description

Sets the frequency of the specified marker to be the center frequency of the analyzer.

Parameter

Name	Type	Range	Default
<n>	Discrete	1 2 3 4 5 6 7 8	--

Remarks

It is disabled for the marker in the DTF time-domain trace window.

Example

The following command sets the frequency of Marker 1 (Position) to the center frequency of the analyzer.

```
:CALCulate:MARKer1:SET:CENTer
```

:CALCulate:MARKer<n>[:SET]:RLEVel**Syntax**

:CALCulate:MARKer<n>[:SET]:RLEVel

Description

Sets the amplitude of the specified marker to the reference value of the current trace window.

Parameter

Name	Type	Range	Default
<n>	Discrete	1 2 3 4 5 6 7 8	--

Remarks

The reference value cannot be set when the trace format is "Smith" or "Polar".

Example

The following command sets the amplitude of Marker 1 (Position) to be the reference value of the current trace window.

:CALCulate:MARKer1:SET:RLEVel

:CALCulate:MARKer<n>[:SET]:START**Syntax**

:CALCulate:MARKer<n>[:SET]:START

Description

Sets the frequency of the specified marker to the start frequency of the analyzer.

Parameter

Name	Type	Range	Default
<n>	Discrete	1 2 3 4 5 6 7 8	--

Remarks

It is disabled for the marker in the DTF time-domain trace window.

Example

The following command sets the frequency of Marker 1 to the start frequency of the analyzer.

:CALCulate:MARKer1:SET:START

:CALCulate:MARKer<n>[:SET]:STOP**Syntax**

:CALCulate:MARKer<n>[:SET]:STOP

Description

Sets the frequency of the specified marker to the stop frequency of the analyzer.

Parameter

Name	Type	Range	Default
<n>	Discrete	1 2 3 4 5 6 7 8	--

Remarks

It is disabled for the marker in the DTF time-domain trace window.

Example

The following command sets the frequency of Marker 1 to the stop frequency of the analyzer.

```
:CALCulate:MARKer1:SET:STOP
```

:CALCulate:MARKer<n>:X**Syntax**

```
:CALCulate:MARKer<n>:X <param>
```

```
:CALCulate:MARKer<n>:X?
```

Description

Sets the X-axis value of the specified marker on the current trace.

Queries the X-axis value of the specified marker on the current trace.

Parameter

Name	Type	Range	Default
<n>	Discrete	1 2 3 4 5 6 7 8	--
<param>	Consecutive Real Number	Refer to "Remarks"	--

Remarks

For the frequency-domain trace window in S11, S21, and DTF measurement, the available values for X-axis are as shown in the following table.

Marker Type	Range	Unit
Position	0 to Fmax	Hz
Delta	-Fmax to Fmax	Hz

For the time-domain trace window in DTF measurement, the available values for X-axis are as shown in the following table.

Marker Type	Range	Unit
Position	0 to stop distance	meter/feet
Delta	- stop distance to stop distance	meter/feet

Return Format

The query returns the X-axis value of the specified marker in scientific notation.

Example

The following command sets the X-axis value of Marker 1 to 150 MHz.

```
:CALCulate:MARKer1:X 150000000
```

The following query returns 1.500000000e+08.

```
:CALCulate:MARKer1:X?
```

:CALCulate:MARKer<n>:Y**Syntax**

```
:CALCulate:MARKer<n>:Y?
```

Description

Queries the Y-axis value of the specified marker on the current trace.

Parameter

Name	Type	Range	Default
<n>	Discrete	1 2 3 4 5 6 7 8	--

Return Format

The query returns the Y-axis value of the specified marker in strings.

Example

The following query returns 0.12,-114.36;

```
:CALCulate:MARKer1:Y?
```

:CALCulate:TRACe:GDELay:APERture**Syntax**

```
:CALCulate:TRACe:GDELay:APERture <integer>
```

```
:CALCulate:TRACe:GDELay:APERture?
```

Description

Sets the aperture step width for the group delay.

Queries the aperture step width for the group delay.

Parameter

Name	Type	Range	Default
<integer>	Integer	1 to (sweep points/10)	10

Return Format

The query returns the aperture step width for the group delay in scientific notation.

Example

The following command sets the aperture step width for the group delay to 15.

```
:CALCulate:TRACe:GDELay:APERture 15
```

The following query returns 1.500000000e+01.

```
:CALCulate:TRACe:GDELay:APERture?
```

:CALCulate:TRACe<n>:MATH:MEMorize**Syntax**

```
:CALCulate:TRACe<n>:MATH:MEMorize
```

Description

Saves the measurement data of the currently selected trace to the memory.

Parameter

Name	Type	Range	Default
<n>	Discrete	1 2 3 4	--

Example

The following command stores the measurement data of Trace 1 to the memory.

```
:CALCulate:TRACe1:MATH:MEMorize
```

:CALibration Commands

Command List:

- ◆ [:CALibration:CKIT:C0](#)
- ◆ [:CALibration:CKIT:C1](#)
- ◆ [:CALibration:CKIT:C2](#)
- ◆ [:CALibration:CKIT:C3](#)
- ◆ [:CALibration:CKIT:L0](#)
- ◆ [:CALibration:CKIT:L1](#)
- ◆ [:CALibration:CKIT:L2](#)
- ◆ [:CALibration:CKIT:L3](#)
- ◆ [:CALibration:CKIT:LABel](#)
- ◆ [:CALibration:CKIT:LENGth](#)
- ◆ [:CALibration:CKIT:LOSS](#)
- ◆ [:CALibration:CKIT:TYPE](#)
- ◆ [:CALibration:CKIT:Z0](#)
- ◆ [:CALibration:CLEAr](#)
- ◆ [:CALibration:DTF:ABORT](#)
- ◆ [:CALibration:DTF:LOAD](#)
- ◆ [:CALibration:DTF:OPEN](#)
- ◆ [:CALibration:DTF:SAVE](#)
- ◆ [:CALibration:DTF:SHORT](#)
- ◆ [:CALibration:S11:ABORT](#)
- ◆ [:CALibration:S11:LOAD](#)
- ◆ [:CALibration:S11:OPEN](#)
- ◆ [:CALibration:S11:SAVE](#)
- ◆ [:CALibration:S11:SHORT](#)
- ◆ [:CALibration:S21:ABORT](#)
- ◆ [:CALibration:S21:SAVE](#)
- ◆ [:CALibration:S21:THROUGH](#)

:CALibration:CKIT:C0

Syntax

:CALibration:CKIT:C0 <C0-value>
:CALibration:CKIT:C0?

Description

Sets the value of the parameter C0 for the Open standard.
Queries the value of the parameter C0 for the Open standard.

Parameter

Name	Type	Range	Default
<C0-value>	Consecutive Real Number	-100 GF to 100 GF	0.00 fF

Remarks

The unit of the return value is fF.

Return Format

The query returns the value of the parameter C0 for the Open standard in scientific notation.

Example

The following command sets the value of the parameter C0 for the Open standard to -2.71202 fF.
:CALibration:CKIT:C0 -2.71202

The following query returns -2.712020000e+00.
:CALibration:CKIT:C0?

:CALibration:CKIT:C1**Syntax**

:CALibration:CKIT:C1 <C1-value>
:CALibration:CKIT:C1?

Description

Sets the value of the parameter C1 for the Open standard.
Queries the value of the parameter C1 for the Open standard.

Parameter

Name	Type	Range	Default
<C1-value>	Consecutive Real Number	-100GF/GHz to 100GF/GHz	0.00 fF/GHz

Remarks

The unit of the return value is fF/GHz.

Return Format

The query returns the value of the parameter C1 for the Open standard in scientific notation.

Example

The following command sets the value of the parameter C1 for the Open standard to 2.47817088 fF/GHz.
:CALibration:CKIT:C1 2.47817088

The following query returns 2.478170880e+00.
:CALibration:CKIT:C1?

:CALibration:CKIT:C2**Syntax**

:CALibration:CKIT:C2 <C2-value>
:CALibration:CKIT:C0?

Description

Sets the value of the parameter C2 for the Open standard.
Queries the value of the parameter C2 for the Open standard.

Parameter

Name	Type	Range	Default
<C2-value>	Consecutive Real Number	-100 GF/GHz ² to 100 GF/GHz ²	0.00 fF/GHz ²

Remarks

The unit of the return value is fF/GHz².

Return Format

The query returns the value of the parameter C2 for the Open standard in scientific notation.

Example

The following command sets the value of the parameter C2 for the Open standard to -0.1973063668 fF/GHz².

```
:CALibration:CKIT:C2 -0.1973063668
```

The following query returns -1.973063668e-01.

```
:CALibration:CKIT:C2?
```

:CALibration:CKIT:C3**Syntax**

```
:CALibration:CKIT:C3 <C3-value>
```

```
:CALibration:CKIT:C3?
```

Description

Sets the value of the parameter C3 for the Open standard.

Queries the value of the parameter C3 for the Open standard.

Parameter

Name	Type	Range	Default
<C3-value>	Consecutive Real Number	-100 GF/GHz ³ to 100 GF/GHz ³	0.00 fF/GHz ³

Remarks

The unit of the return value is fF/GHz³.

Return Format

The query returns the value of the parameter C3 for the Open standard in scientific notation.

Example

The following command sets the value of the parameter C3 for the Open standard to -0.02094 fF/GHz³.

```
:CALibration:CKIT:C3 -0.02094
```

The following query returns -2.094000000e-02.

```
:CALibration:CKIT:C3?
```

:CALibration:CKIT:L0**Syntax**

```
:CALibration:CKIT:L0 <L0-value>
```

```
:CALibration:CKIT:L0?
```

Description

Sets the value of the parameter L0 for the Short standard.

Queries the value of the parameter L0 for the Short standard.

Parameter

Name	Type	Range	Default
<L0-value>	Consecutive Real Number	-100 GH to 100 GH	0.00 pH

Remarks

The unit of the return value is pH.

Return Format

The query returns the value of the parameter L0 for the Short standard in scientific notation.

Example

The following command sets the value of the parameter L0 for the Short standard to -18.16506839 pH.
:CALibration:CKIT:L0 -18.16506839

The following query returns -1.816506839e+01.
:CALibration:CKIT:L0?

:CALibration:CKIT:L1**Syntax**

:CALibration:CKIT:L1 <L1-value>
:CALibration:CKIT:L1?

Description

Sets the value of the parameter L1 for the Short standard.
Queries the value of the parameter L1 for the Short standard.

Parameter

Name	Type	Range	Default
<L1-value>	Consecutive Real Number	-100 GH/GHz to 100 GH/GHz	0.00 pH/GHz

Remarks

The unit of the return value is pH/GHz.

Return Format

The query returns the value of the parameter L1 for the Short standard in scientific notation.

Example

The following command sets the value of the parameter L1 for the Short standard to 28.77678 pH/GHz.
:CALibration:CKIT:L1 28.77678

The following query returns 2.877678000e+01.
:CALibration:CKIT:L1?

:CALibration:CKIT:L2**Syntax**

:CALibration:CKIT:L2 <L2-value>
:CALibration:CKIT:L2?

Description

Sets the value of the parameter L2 for the Short standard.
Queries the value of the parameter L2 for the Short standard.

Parameter

Name	Type	Range	Default
<L2-value>	Consecutive Real Number	-100 GH/GHz ² to 100 GH/GHz ²	0.00 pH/GHz ²

Remarks

The unit of the return value is pH/GHz².

Return Format

The query returns the value of the parameter L2 for the Short standard in scientific notation.

Example

The following command sets the value of the parameter L2 for the Short standard to -8.6055475 pH/GHz².
:CALibration:CKIT:L2 -8.6055475

The following query returns -8.605547500e+00.
:CALibration:CKIT:L2?

:CALibration:CKIT:L3**Syntax**

:CALibration:CKIT:L3 <L3-value>
:CALibration:CKIT:L3?

Description

Sets the value of the parameter L3 for the Short standard.
Queries the value of the parameter L3 for the Short standard.

Parameter

Name	Type	Range	Default
<L3-value>	Consecutive Real Number	0 GH/GHz ³ to 100 GH/GHz ³	0.00 pH/GHz ³

Remarks

The unit of the return value is pH/GHz³.

Return Format

The query returns the value of the parameter L3 for the Short standard in scientific notation.

Example

The following command sets the value of the parameter L3 for the Short standard to 0.6595 pH/GHz³.
:CALibration:CKIT:L3 0.6595

The following query returns 6.595000000e-01.
:CALibration:CKIT:L3?

:CALibration:CKIT:LABel**Syntax**

:CALibration:CKIT:LABel CK106A|CK106E|CUSTom
:CALibration:CKIT:LABel?

Description

Selects the calibration kit.
Queries the calibration kit.

Parameter

Name	Type	Range	Default
--	Keyword	CK106A CK106E CUSTom	CK106A

Return Format

The query returns CK106A, CK106E, or CUST.

Example

The following command selects the calibration kit CK106A.

```
:CALibration:CKIT:LABel CK106A
```

The following command returns CK106A.

```
:CALibration:CKIT:LABel?
```

:CALibration:CKIT:LENGth**Syntax**

```
:CALibration:CKIT:LENGth <length>
```

```
:CALibration:CKIT:LENGth?
```

Description

Sets the offset length of the current calibration standard.

Queries the offset length of the current calibration standard.

Parameter

Name	Type	Range	Default
<length>	Consecutive Real Number	0.00 m to 100 Gm	0.00 m

Return Format

The query returns the offset length in scientific notation.

Example

The following command sets the offset length of the current calibration standard to 0.002 m.

```
:CALibration:CKIT:LENGth 0.002
```

The following query returns 2.000000000e-03.

```
:CALibration:CKIT:LENGth?
```

:CALibration:CKIT:LOSS**Syntax**

```
:CALibration:CKIT:LOSS <LOSS>
```

```
:CALibration:CKIT:LOSS?
```

Description

Sets the loss for the Through standard.

Queries the loss for the Through standard.

Parameter

Name	Type	Range	Default
<LOSS>	Consecutive Real Number	0.00 dB to 100G dB	0.00 dB

Remarks

The unit of the return value is dB.

Return Format

The query returns the loss for the Through standard in scientific notation in scientific notation.

Example

The following command sets the loss for the Through standard to 2 dB.

```
:CALibration:CKIT:LOSS 2
```

The following query returns 2.000000000e+00.

```
:CALibration:CKIT:LOSS?
```

:CALibration:CKIT:TYPE**Syntax**

```
:CALibration:CKIT:TYPE OPEN|SHORT|LOAD|THROUGH
```

```
:CALibration:CKIT:TYPE?
```

Description

Selects the calibration kit type.

Queries the calibration kit type.

Parameter

Name	Type	Range	Default
--	Keyword	OPEN SHORT LOAD THROUGH	OPEN

Remarks

The parameters indicate Open, Short, Load, and Through calibration types respectively.

Return Format

The following query returns OPEN, SHOR, LOAD, or THRU.

Example

The following command selects THROUGH as the calibration kit type.

```
:CALibration:CKIT:TYPE THROUGH
```

The following query returns THRU.

```
:CALibration:CKIT:TYPE?
```

:CALibration:CKIT:Z0**Syntax**

```
:CALibration:CKIT:Z0 <Z0>
```

```
:CALibration:CKIT:Z0
```

Description

Sets the value of the parameter R for the Load standard.

Queries the value of the parameter R for the Load standard.

Parameter

Name	Type	Range	Default
<Z0>	Consecutive Real Number	-100 G Ω to 100 G Ω	50 Ω

Remarks

The unit of the return value is Ω .

Return Format

The query returns the value of the parameter R for the Load standard in scientific notation.

Example

The following command sets the value of the parameter R for the Load standard to 50 Ω .

```
:CALibration:CKIT:Z0 50
```

The following query returns 5.000000000e+01.

```
:CALibration:CKIT:Z0?
```

:CALibration:CLEAr**Syntax**

```
:CALibration:CLEAr
```

Description

Clears the saved calibration coefficients.

:CALibration:DTF:ABORt**Syntax**

```
:CALibration:DTF:ABORt
```

Description

Aborts the calibration for DTF measurement.

:CALibration:DTF:LOAD**Syntax**

```
:CALibration:DTF:LOAD
```

Description

Performs the Load calibration for DTF measurement.

:CALibration:DTF:OPEN**Syntax**

```
:CALibration:DTF:OPEN
```

Description

Performs the Open calibration for DTF measurement.

:CALibration:DTF:SAVE**Syntax**

```
:CALibration:DTF:SAVE
```

Description

Saves the calibration coefficients for DTF measurement.

:CALibration:DTF:SHORT**Syntax**

:CALibration:DTF:SHORT

Description

Performs the Short calibration for DTF measurement.

:CALibration:S11:ABORT**Syntax**

:CALibration:S11:ABORT

Description

Aborts the calibration for S11 measurement.

:CALibration:S11:LOAD**Syntax**

:CALibration:S11:LOAD

Description

Performs the Load calibration for S11 measurement.

:CALibration:S11:OPEN**Syntax**

:CALibration:S11:OPEN

Description

Performs the Open calibration for S11 measurement.

:CALibration:S11:SAVE**Syntax**

:CALibration:S11:SAVE

Description

Saves the calibration coefficients for S11 measurement.

:CALibration:S11:SHORT**Syntax**

:CALibration:S11:SHORT

Description

Performs the Short calibration for S11 measurement.

:CALibration:S21:ABORt**Syntax**

:CALibration:S21:ABORt

Description

Aborts calibration for S21.

:CALibration:S21:SAVE**Syntax**

:CALibration:S21:SAVE

Description

Saves the calibration coefficients for S21 measurement.

:CALibration:S21:THROugh**Syntax**

:CALibration:S21:THROugh

Description

Performs the Through calibration for S21 measurement.

:CONFigure Command

Command List:

- ◆ [:CONFigure](#)

:CONFigure

Syntax

:CONFigure S11|S21|DTF
:CONFigure?

Description

Sets the current measurement function to S11, S21, or DTF.
Queries the current measurement function.

Parameter

Name	Type	Range	Default
--	Keyword	S11 S21 DTF	--

Return Format

The query returns S11, S21, or DTF.

:DISPlay Commands

Command List:

- ◆ [:DISPlay:TRACe<n>:FORMat](#)
- ◆ [:DISPlay:TRACe<n>:SOURce](#)
- ◆ [:DISPlay:TRACe<n>:Y\[:SCALe\]:AUTO](#)
- ◆ [:DISPlay:TRACe<n>:Y\[:SCALe\]:PDIVision](#)
- ◆ [:DISPlay:TRACe<n>:Y\[:SCALe\]:RLEVEL](#)
- ◆ [:DISPlay:TRACe<n>:Y\[:SCALe\]:RPOSITION](#)
- ◆ [:DISPlay:TRACe:Y\[:SCALe\]:AUTO:ALL](#)
- ◆ [:DISPlay:WINDow:FORMat](#)
- ◆ [:DISPlay:WINDow:SElect](#)
- ◆ [:DISPlay:WINDow:TRACe:Y\[:SCALe\]:RLEVEL](#)

:DISPlay:TRACe<n>:FORMat

Syntax

```
:DISPlay:TRACe<n>:FORMat <para>
:DISPlay:TRACe<n>:FORMat?
```

Description

Sets the display format of the specified trace in the current measurement function.
Queries the display format of the specified trace in the current measurement function.

Parameter

Name	Type	Range	Default
<n>	Discrete	DTF: 1 2 S11/S21: 1 2 3 4	--
<para>	Keyword	For DTF: TRACE1: TLOG TLINear TRACE2: MLINear SWR RLOSs For S11: MLOGarithmic PHASe GDELay SLINear SLOGarithmic SCOMplex SMITh SADMittance PLINear PLOGarithmic POLar MLINear SWR REAL IMAGinary UPHase PPHase For S21: MLOGarithmic PHASe GDELay MLINear UPHase PPHase	For DTF: TRACE1: TLIN TRACE2: SWR For S11: MLOGarithmic For S21: MLOGarithmic

Return Format

For DTF, the query returns TLOG or TLIN for Trace 1; the query returns MLIN, SWR, or RLOS for Trace 2.
For S11, the query returns MLOG, PHAS, GDEL, SLIN, SLOG, SCOM, SMIT, SADM, PLIN, PLOG, POL, MLIN, SWR, REAL, IMAG, UPH, or PPH.
For S21, the query returns MLOG, PHAS, GDEL, MLIN, UPH, or PPH.

Example

In DTF, the following command sets the display format of Trace 1 to TLOG.
:DISPlay:TRACe1:FORMat TLOG

The following query returns TLOG.
:DISPlay:TRACe1:FORMat?

In S11, the following command sets the display format of Trace 1 to MLOGarithmic.
:DISPlay:TRACe1:FORMat MLOGarithmic|

The following query returns MLOG.
:DISPlay:TRACe1:FORMat?

In S21, the following command sets the display format of Trace 1 to MLOGarithmic.
:DISPlay:TRACe1:FORMat MLOGarithmic|

The following query returns MLOG.
:DISPlay:TRACe1:FORMat?

:DISPlay:TRACe<n>:SOURce

Syntax

```
:DISPlay:TRACe<n>:SOURce DATA|MEMory|BOTH|OFF
:DISPlay:TRACe<n>:SOURce?
```

Description

Sets the data source of the specified trace.
Queries the data source of the specified trace.

Parameter

Name	Type	Range	Default
<n>	Discrete	1 2 3 4	--
--	Keyword	DATA MEMory BOTH OFF	DATA

Return Format

The query returns DATA, MEM, BOTH, or OFF.

Example

The following command sets the data source of Trace 1 to DATA.

```
:DISPlay:TRACe1:SOURce DATA
```

The following query returns DATA.

```
:DISPlay:TRACe1:SOURce?
```

:DISPlay:TRACe<n>:Y[:SCALE]:AUTO

Syntax

```
:DISPlay:TRACe<n>:Y[:SCALE]:AUTO
```

Description

Auto sets the Y-axis reference and scale.

:DISPlay:TRACe<n>:Y[:SCALE]:PDIVision

Syntax

```
:DISPlay:TRACe<n>:Y[:SCALE]:PDIVision <rel>
:DISPlay:TRACe<n>:Y[:SCALE]:PDIVision?
```

Description

Sets the Y-axis scale of the specified trace.
Queries the Y-axis scale of the specified trace.

Parameter

Name	Type	Range	Default
<n>	Discrete	1 to 4	--
<rel>	Consecutive Real Number	Refer to "Remarks"	Refer to "Remarks"

Remarks

When you select a different trace format, the range of the Y-axis scale and its default value is different.

Trace Format	Default	Range	Unit
Log Mag	10	100f to 100G	dB
Lin Mag	100	1a to 100G	N/A

Phase	90	1a to 100G	degree (°)
Group Delay	10	1a to 100G	ns
Real	200	1a to 100G	N/A
Imaginary	200	1a to 100G	N/A
SWR	1	1a to 100G	N/A
Smith	1	0.03 to 20	N/A
Polar	1	0.03 to 20	N/A
Expand Phase	90	1a to 100G	degree (°)
Positive Phase	90	1a to 100G	degree (°)
Return Loss (DTF)	10	100f to 100G	dB
Log Mag(DTF)	10	100f to 100G	dB
Lin Mag(DTF)	0.1	1a to 100G	N/A

Return Format

The query returns the Y-axis value of the selected trace in scientific notation.

Example

The following command sets the Y-axis value of Trace 1 to 2.5 dB when the trace format is Log Mag.
:DISPlay:TRACe1:Y:SCALE:PDIVision 2.5

The following query returns 2.500000000e+00.
:DISPlay:TRACe1:Y:SCALE:PDIVision?

:DISPlay:TRACe<n>:Y[:SCALE]:RLEVEL

Syntax

:DISPlay:TRACe<n>:Y[:SCALE]:RLEVEL <real>
:DISPlay:TRACe<n>:Y[:SCALE]:RLEVEL?

Description

Sets the reference value of the selected trace.
Sets the reference value of the selected trace.

Parameter

Name	Type	Range	Default
<n>	Discrete	1 2 3 4	--
<real>	Consecutive Real Number	Refer to "Remarks"	Refer to "Remarks"

Remarks

When the trace format is "Smith" or "Polar", the reference value is unavailable.

When you select other trace formats, the reference value of the selected trace is shown in the following table.

Trace Format	Default	Range	Unit
Log Mag	0	-500G to 500G	dB
Lin Mag	0	-500G to 500G	N/A
Phase	0	-500G to 500G	degree (°)
Group Delay	0	-500G to 500G	ns
Real	0	-500G to 500G	N/A
Imaginary	0	-500G to 500G	N/A
SWR	1.0	-500G to 500G	N/A
Expand Phase	0	-500G to 500G	degree (°)
Positive Phase	180	-500G to 500G	degree (°)
Return Loss(DTF)	0	-500G to 500G	dB
Log Mag(DTF)	-100	-500G to 500G	dB

Lin Mag(DTF)	0	-500G to 500G	N/A
---------------------	---	---------------	-----

Return Format

The query returns the reference value of the selected trace in scientific notation.

Example

The following command sets the reference value of Trace 1 to 1.5.

```
:DISPlay:TRACe1:Y:SCALE:RLEVEL 1.5
```

The following query returns 1.500000000e+00.

```
:DISPlay:TRACe1:Y[:SCALE]:RLEVEL?
```

:DISPlay:TRACe<n>:Y[:SCALE]:RPOSITION**Syntax**

```
:DISPlay:TRACe<n>:Y[:SCALE]:RPOSITION <real>
```

```
:DISPlay:TRACe<n>:Y[:SCALE]:RPOSITION?
```

Description

Sets the Y-axis reference position of the selected trace.

Queries the Y-axis reference position of the selected trace.

Parameter

Name	Type	Range	Default
<n>	Discrete	1 2 3 4	--
<real>	Integer	0 to 10	Refer to "Remarks"

Remarks

The default values of the reference position for different trace formats are as follows:

- When the trace format is Lin Mag, SWR, Lin Mag(DTF), or Log Mag(DTF), the default value of the reference position is 0.
- When the trace format is Log Mag, Phase, Group Delay, Real, Imaginary, Expand Phase, Positive Phase, or Return Loss(DTF), the default value of the reference position is 5.

When the format is "Smith" or "Polar", the reference position is unavailable.

Return Format

The query returns the Y-axis reference position of the selected trace in integer.

Example

The following command sets the Y-axis reference position of Trace 1 to 3.

```
:DISPlay:TRACe1:Y:RPOSITION 3
```

The following query returns 3.

```
:DISPlay:TRACe1:Y:RPOSITION?
```

:DISPlay:TRACe:Y[:SCALE]:AUTO:ALL**Syntax**

```
:DISPlay:TRACe:Y[:SCALE]:AUTO:ALL
```

Description

Auto adjusts the Y-axis reference and scale of all the selected traces.

:DISPlay:WINDow:FORMat

Syntax

:DISPlay:WINDow:FORMat SINGLE|LRWindow|UDWindow|LRDWindow|UDRWindow|QUAD
 :DISPlay:WINDow:FORMat?

Description

Sets the trace window layout of the current mode.
 Queries the trace window layout of the current mode.

Parameter

Name	Type	Range	Default
--	Keyword	SINGLE LRWindow UDWindow LRDWindow UDRWindow QUAD	S11: QUAD S21/DTF: UDWindow

Remarks

SINGLE: single window.
 LRWindow: left and right windows.
 UDWindow: top and bottom windows.
 LRD Window: left, right, and bottom windows
 UDR Window: top, bottom, and right windows.
 QUAD: four windows.

Return Format

The query returns the window layout.

Example

The following command sets the trace window layout of the current mode to QUAD.
 :DISPlay:WINDow:FORMat QUAD

The following query returns QUAD.
 :DISPlay:WINDow:FORMat?

:DISPlay:WINDow:SElect

Syntax

:DISPlay:WINDow:SElect <trace>
 :DISPlay:WINDow:SElect?

Description

Selects a trace window.
 Queries the selected trace window.

Parameter

Name	Type	Range	Default
<trace>	Discrete	1 2 3 4	1

Return Format

The query returns an integer.

Example

The following command selects Trace 3 window.
 :DISPlay:WINDow:SElect 3

The following query returns 3.
:DISPlay:WINDow:SElect?

:DISPlay:WINDow:TRACe:Y[:SCALe]:RLEVel

Syntax

:DISPlay:WINDow:TRACe:Y[:SCALe]:RLEVel < RLEVel >
:DISPlay:WINDow:TRACe:Y[:SCALe]:RLEVel?

Description

Sets the reference level.
Queries the reference level.

Parameter

Name	Type	Range	Default
RLEVel	Consecutive Real Number	-170 dBm to 30 dBm	-10 dBm

Return Format

The query returns the reference level in scientific notation.

Example

The following command sets the reference level to 15 dB.
:DISPlay:WINDow:TRACe:Y:RLEVel15

The following query returns 1.500000000e+01.
:DISPlay:WINDow:TRACe:Y:RLEVel?

IEEE 488.2 Common Commands

IEEE 488.2 common commands are used to operate or query the status registers. For the structure of the status register, refer to "[:STATUS Commands](#)".

Command List:

- ◆ [*CLS](#)
- ◆ [*ESE](#)
- ◆ [*ESR?](#)
- ◆ [*IDN?](#)
- ◆ [*OPC](#)
- ◆ [*RCL](#)
- ◆ [*RST](#)
- ◆ [*SAV](#)
- ◆ [*SRE](#)
- ◆ [*STB?](#)
- ◆ [*TRG](#)
- ◆ [*TST?](#)
- ◆ [*WAI](#)

CLS*Syntax**

*CLS

Description

Clears all the event registers and status byte registers.

ESE*Syntax**

*ESE <value>

*ESE?

Description

Sets the enable register for the standard event status register.

Queries the enable register for the standard event status register.

Parameter

Name	Type	Range	Default
<value>	Integer	Refer to "Remarks"	0

Remarks

Bit 2, bit 3, bit 4, and bit 7 are reserved; you can set their values but they will not affect the system. Bit 1 and bit 6 are not used and are always treated as 0; therefore, the range of <value> are the decimal numbers corresponding to the binary numbers ranging from 00000000 (0 in decimal) to 11111111 (255 in decimal) and of which bit 1 and bit 6 are 0.

Return Format

The query returns an integer. The integer equals to the binary-weighted sum of all the bits set in the register. For example, the query returns 144 if bit 4 (16 in decimal) and bit 7 (128 in decimal) are enabled.

Example

The following command sets the enable register for the standard event status register to 16.

*ESE 16

The following query returns 16.

*ESE?

ESR?*Syntax**

*ESR?

Description

Queries and clears the event register for the standard event status register.

Remarks

Bit 1 and bit 6 in the standard event status register are not in use, and are regarded as 0. The query returns a decimal value that corresponds to the binary values ranging from 00000000 (0 in decimal) to 11111111 (255 in decimal) and of which bit 1 and bit 6 are 0.

Return Format

The query returns an integer. The integer equals to the binary-weighted sum of all the bits set in the register. For example, the query returns 144 if bit 4 (16 in decimal) and bit 7 (128 in decimal) are enabled.

Example

The following query returns 24 (bit 3 and bit 4 have been set).
*ESR?

IDN?*Syntax**

*IDN?

Description

Queries the ID string of the instrument.

Return Format

The query returns the ID string in the following format:
Rigol Technologies,<model>,<serial number>,XX.XX.XX
<model>: instrument model
<serial number>: serial number of the instrument
XX.XX.XX: software version of the instrument

Example

The following query returns Rigol Technologies,RSA5065N,RSA5F222900001,00.03.00.
*IDN?

OPC*Syntax**

*OPC
*OPC?

Description

Sets bit 0 (Operation Complete, OPC) in the standard event status register to 1 after the current operation is finished.

Queries whether the current operation is finished.

Return Format

The query returns 1 after the current operation is finished; otherwise, the query returns 0.

RCL*Syntax**

*RCL <integer>

Description

Recalls the selected register.

Parameter

Name	Type	Range	Default
<integer>	Integer	1 to 16	--

Example

The following command recalls Register 1.

```
*RCL 1
```

RST*Syntax**

```
*RST
```

Description

Restores the instrument to its factory default settings.

SAV*Syntax**

```
*SAV <integer>
```

Description

Saves the current instrument state to the selected register.

Parameter

Name	Type	Range	Default
<integer>	Integer	1 to 16	--

Example

The following command saves the current instrument state to Register 1.

```
*SAV 1
```

SRE*Syntax**

```
*SRE <value>
```

```
*SRE?
```

Description

Sets the enable register for the status byte register.

Queries the enable register for the status byte register.

Parameter

Name	Type	Range	Default
<value>	Integer	Refer to " Remarks "	0

Remarks

Bit 0 and bit 1 are not used and are always treated as 0; therefore, the range of <value> are the decimal numbers corresponding to the binary numbers ranging from 00000000 (0 in decimal) to 11111111 (255 in decimal) and of which bit 0 and bit 1 are 0.

Return Format

The query returns an integer. The integer equals to the binary-weighted sum of all the bits set in the register. For example, the query returns 144 if bit 4 (16 in decimal) and bit 7 (128 in decimal) are enabled.

Example

The following command sets the enable register for the status byte register to 16.

*SRE 16

The following query returns 16.

*SRE?

*STB?

Syntax

*STB?

Description

Queries the event register for the status byte register.

Remarks

Bit 0 and bit 1 in the status byte register are not in use, and are regarded as 0. The query returns a decimal value that corresponds to the binary values ranging from 00000000 (0 in decimal) to 11111111 (255 in decimal) and of which bit 0 and bit 1 are 0.

Return Format

The query returns an integer. The integer equals to the binary-weighted sum of all the bits set in the register. For example, the query returns 144 if bit 4 (16 in decimal) and bit 7 (128 in decimal) are enabled.

Example

The following query returns 24 (bit 3 and bit 4 have been set).

*STB?

*TRG

Syntax

*TRG

Description

Triggers a sweep or measurement immediately.

*TST?

Syntax

*TST?

Description

Queries whether the self-check operation is finished.

Remarks

The query returns 0 or 1. A zero is returned if the test is successful, 1 if it fails.

*WAI

Syntax

*WAI

Description

Waits for all the pending operations to complete before executing any additional commands.

:INITiate Commands

Command List:

- ◆ [:INITiate:CONTInuous](#)
- ◆ [:INITiate:IMMEDIATE](#)

:INITiate:CONTInuous

Syntax

```
:INITiate:CONTInuous OFF|ON|0|1
```

```
:INITiate:CONTInuous?
```

Description

Sets the sweep type to Continuous or Single.
Queries the current sweep type.

Parameter

Name	Type	Range	Default
--	Bool	OFF ON 0 1	ON 1

Remarks

ON|1: continuous sweep.

OFF|0: single sweep.

Return Format

The query returns 0 or 1.

Example

The following command sets the sweep type to Continuous.

```
:INITiate:CONTInuous ON or :INITiate:CONTInuous 1
```

The following query returns 1.

```
:INITiate:CONTInuous?
```

:INITiate:IMMEDIATE

Syntax

```
:INITiate:IMMEDIATE
```

Description

Sets the sweep type to Single.

:INSTrument Commands

Command List:

- ◆ [:INSTrument\[:SElect\]](#)
- ◆ [:INSTrument:NSElect](#)

:INSTrument[:SElect] :INSTrument:NSElect

Syntax

```
:INSTrument[:SElect] SA|RTSA|VSA|EMI|VNA
:INSTrument:NSElect 1|2|3|4|5
:INSTrument[:SElect]?
:INSTrument:NSElect?
```

Description

Selects the working mode of the instrument.
Queries the working mode of the instrument.

Parameter

Name	Type	Range	Default
--	Discrete	1 2 3 4 5	1
--	Keyword	SA RTSA VSA EMI VNA	SA

Remarks

The above parameters 1|2|3|4|5 correspond to SA|RTSA|VSA|EMI|VNA, respectively.
After running the command of switching the working mode, we recommend you perform the next operation after a delay of 8 s.

Example

The following command sets the working mode of the instrument to VNA.
:INSTrument:NSElect 5
:INSTrument:SElect VNA

The following query returns 5 or VNA.
:INSTrument:NSElect? or :INSTrument:SElect?

:MMEMory Commands

Command List:

- ◆ [:MMEMory:DELeTe](#)
- ◆ [:MMEMory:LOAD:STATe](#)
- ◆ [:MMEMory:LOAD:TRACe](#)
- ◆ [:MMEMory:STORe:SCReen](#)
- ◆ [:MMEMory:STORe:STATe](#)
- ◆ [:MMEMory:STORe:TRACe](#)

Remarks:

The mode name in the path specified in this manual is "VNA" mode.

:MMEMory:DELeTe

Syntax

:MMEMory:DELeTe <file_name>

Description

Deletes a specified file.

Parameter

Name	Type	Range	Default
<file_name>	ASCII String	--	--

Remarks

<file_name> should contain the path and the filename.

This operation fails if the file with the specified filename does not exist.

Example

The following command deletes the "state1.sta" file from the "/vna/state" folder.

```
:MMEMory:DELeTe /vna/state/state1.sta
```

:MMEMory:LOAD:STATe

Syntax

:MMEMory:LOAD:STATe <file_name>

Description

Loads the specified state file (.sta).

Parameter

Name	Type	Range	Default
<file_name>	ASCII String	--	--

Remarks

This operation fails if the file with the specified filename does not exist.

Example

The following command loads the state file (state1.sta) to the instrument.

```
:MMEMory:LOAD:STATe state1.sta
```

:MMEMory:LOAD:TRACe

Syntax

:MMEMory:LOAD:TRACe <label>,<file_name>

Description

Loads the specified trace+state file (.trs).

Parameter

Name	Type	Range	Default
<label>	Keyword	TRACE1 TRACE2 TRACE3 TRACE4	--
<file_name>	ASCII String	--	--

Remarks

This operation fails if the file with the specified filename does not exist.

Example

The following command loads the state of the file tracestate2.trs to the instrument and loads the trace data to Trace2.

```
:MMEMory:LOAD:TRACe TRACE2,tracestate2.trs
```

:MMEMory:STORe:SCReen**Syntax**

```
:MMEMory:STORe:SCReen <file_name>
```

Description

Saves the current screen image with the specified filename suffixed with ".jpg", ".png/", or ".bmp" to the default path ("/mode name"/screen).

Parameter

Name	Type	Range	Default
<file_name>	ASCII String	--	--

Remarks

If the specified file already exists, overwrite it.

If a suffix (.jpg/.png/.bmp) is added to the filename, you can save the current screen image with a different format based on its different suffix.

If no suffix is added to the filename, then by default, the current screen image is saved in the currently selected format.

Example

The following command saves the current screen image with the filename "screen.jpg" to the folder (/vna/screen).

```
:MMEMory:STORe:SCReen screen.jpg
```

:MMEMory:STORe:STATe**Syntax**

```
:MMEMory:STORe:STATe <file_name>
```

Description

Saves the current instrument state with the specified filename suffixed with ".sta" to the default path ("/mode name"/state).

Parameter

Name	Type	Range	Default
<file_name>	ASCII String	--	--

Remarks

If the specified file already exists, overwrite it.

Example

The following command saves the current instrument state with the filename "state.sta" to the folder

(/vna/state).
:MMEMory:STORe:STATe state

:MMEMory:STORe:TRACe

Syntax

:MMEMory:STORe:TRACe <label>,<file_name>

Description

Saves the specified trace+state file with filename suffixed with ".trs" to the default path ("/mode name"/tracestate).

Parameter

Name	Type	Range	Default
<label>	Keyword	TRACE1 TRACE2 TRACE3 TRACE4	--
<file_name>	ASCII String	--	--

Remarks

If the specified file already exists, overwrite it.

Example

The following command saves the current instrument state and Trace 1 with the filename "mystate.trs" to the folder (/vna/tracestate).

```
:MMEMory:STORe:TRACe TRACE1,mystate
```

:OUTPut Command

Command List:

- ◆ [:OUTPut\[:EXternal\]\[:STATe\]?](#)

:OUTPut[:EXternal][:STATe]?

Syntax

:OUTPut[:EXternal][:STATe]?

Description

Queries the on/off status of TG.

Return Format

The query returns 0 or 1.

[[:SENSe] Commands

Command List:

- ◆ [\[:SENSe\]:AVERage:COUNT](#)
- ◆ [\[:SENSe\]:BANDwidth|BWIDth\[:RESolution\]](#)
- ◆ [\[:SENSe\]:BANDwidth|BWIDth:SHAPE](#)
- ◆ [\[:SENSe\]:CALibration:DTF:DIStance:STOP](#)
- ◆ [\[:SENSe\]:CALibration:DTF:LENGth:UNIT](#)
- ◆ [\[:SENSe\]:CALibration:DTF:LOSS:COAX](#)
- ◆ [\[:SENSe\]:CALibration:DTF:VELOCITY](#)
- ◆ [\[:SENSe\]:CALibration:EXTension:DTF:LENGth:UNIT](#)
- ◆ [\[:SENSe\]:CALibration:EXTension:DTF:PORT1:LENGth](#)
- ◆ [\[:SENSe\]:CALibration:EXTension:DTF:PORT1:LOSS:COAX](#)
- ◆ [\[:SENSe\]:CALibration:EXTension:DTF:PORT1:TIME](#)
- ◆ [\[:SENSe\]:CALibration:EXTension:DTF:PORT1:VELOCITY](#)
- ◆ [\[:SENSe\]:CALibration:EXTension:DTF:STATE](#)
- ◆ [\[:SENSe\]:CALibration:EXTension:S11:LENGth:UNIT](#)
- ◆ [\[:SENSe\]:CALibration:EXTension:S11:PORT1:LENGth](#)
- ◆ [\[:SENSe\]:CALibration:EXTension:S11:PORT1:LOSS:COAX](#)
- ◆ [\[:SENSe\]:CALibration:EXTension:S11:PORT1:TIME](#)
- ◆ [\[:SENSe\]:CALibration:EXTension:S11:PORT1:VELOCITY](#)
- ◆ [\[:SENSe\]:CALibration:EXTension:S11:STATE](#)
- ◆ [\[:SENSe\]:CALibration:EXTension:S21:LENGth:UNIT](#)
- ◆ [\[:SENSe\]:CALibration:EXTension:S21:PORT1:LENGth](#)
- ◆ [\[:SENSe\]:CALibration:EXTension:S21:PORT1:LOSS:COAX](#)
- ◆ [\[:SENSe\]:CALibration:EXTension:S21:PORT1:TIME](#)
- ◆ [\[:SENSe\]:CALibration:EXTension:S21:PORT1:VELOCITY](#)
- ◆ [\[:SENSe\]:CALibration:EXTension:S21:PORT2:LENGth](#)
- ◆ [\[:SENSe\]:CALibration:EXTension:S21:PORT2:LOSS:COAX](#)
- ◆ [\[:SENSe\]:CALibration:EXTension:S21:PORT2:TIME](#)
- ◆ [\[:SENSe\]:CALibration:EXTension:S21:PORT2:VELOCITY](#)
- ◆ [\[:SENSe\]:CALibration:EXTension:S21:STATE](#)
- ◆ [:INPut:IMPedance](#)
- ◆ [\[:SENSe\]:CORRection:IMPedance\[:INPut\]\[:MAGNitude\]](#)
- ◆ [\[:SENSe\]:FREQuency:CENTer](#)
- ◆ [\[:SENSe\]:FREQuency:CENTer:STEP:AUTO](#)
- ◆ [\[:SENSe\]:FREQuency:CENTer:STEP\[:INCRement\]](#)
- ◆ [\[:SENSe\]:FREQuency:SPAN](#)
- ◆ [\[:SENSe\]:FREQuency:SPAN:FULL](#)

- ◆ [\[:SENSe\]:FREQuency:START](#)
- ◆ [\[:SENSe\]:FREQuency:STOP](#)
- ◆ [\[:SENSe\]:SWEep:POINts](#)
- ◆ [\[:SENSe\]:SWEep:TIME](#)
- ◆ [\[:SENSe\]:SWEep:TIME:AUTO](#)

[:SENSe]:AVERAge:COUNT

Syntax

```
[:SENSe]:AVERAge:COUNT <integer>
[:SENSe]:AVERAge:COUNT?
```

Description

Sets the trace average count of the current measurement.
Queries the trace average count of the current measurement.

Parameter

Name	Type	Range	Default
<integer>	Integer	1 to 10,000	100

Return Format

The query returns the average count in integer.

Example

The following command sets the average count to 100.
:SENSe:AVERAge:COUNT 100

The following query returns 100.
:SENSe:AVERAge:COUNT?

[:SENSe]:BANDwidth | BWIDth[:RESolution]

Syntax

```
[:SENSe]:BANDwidth|BWIDth[:RESolution] <freq>
[:SENSe]:BANDwidth|BWIDth[:RESolution]?
```

Description

Sets the IF BW value.
Queries the IF BW value.

Parameter

Name	Type	Range	Default
<freq>	Discrete	1 kHz to 10 MHz (at 1-3-10 step)	1 kHz

Remarks

The available IF BW values are from 1 kHz to 10 MHz, at 1-3-10 step. After IF BW is selected by users, the system will compare it with the available values of IF BW. The IF BW value that is closest to the set value will prevail.

Return Format

The query returns the IF BW value in scientific notation.

Example

The following command sets IF BW to 1000 Hz.
:SENSe:BANDwidth:RESolution 1000

The following query returns 1.000000000e+03.
:SENSe:BANDwidth:RESolution?

[[:SENSe]:BANDwidth | BWIDth:SHAPE**Syntax**

[[:SENSe]:BANDwidth|BWIDth:SHAPE RECTangular|HANNing|GAUSSian|FLATtop|HAMMing
[:SENSe]:BANDwidth|BWIDth:SHAPE?

Description

Sets the FFT window for DTF measurement.
Queries the FFT window for DTF measurement.

Parameter

Name	Type	Range	Default
--	Keyword	RECTangular HANNing GAUSSian FLATtop HAMMing	RECTangular

Return Format

The query returns RECT, HANN, GAUS, FLAT, or HAMM.

Example

The following command sets FFT window to HAMMing.
:SENSe:BANDwidth:SHAPE HAMMing

The following query returns HAMM.
:SENSe:BANDwidth:SHAPE?

[[:SENSe]:CALibration:DTF:DISTance:STOP**Syntax**

[[:SENSe]:CALibration:DTF:DISTance:STOP <distance>
[:SENSe]:CALibration:DTF:DISTance:STOP?

Description

Sets the stop distance for DTF measurement.
Queries the stop distance for DTF measurement.

Parameter

Name	Type	Range	Default
<distance>	Consecutive Real Number	0.231 m to 150 Gm	6.72 m

Remarks

The parameters related to the stop distance include Span, Sweep Points, and Velocity Factor. Their relationship is shown in the following formula:

$$\text{Stop Distance} = \frac{(\text{Sweep Points} - 1) * \text{Velocity Factor} * 1.5 * 10^8}{\text{Span}}$$

Return Format

The query returns the stop distance in scientific notation.

Example

The following command sets the stop distance to 5 m.
`:SENSe:CALibration:DTF:DISTance:STOP 5`

The following query returns 5.000000000e+00.
`:SENSe:CALibration:DTF:DISTance:STOP?`

[[:SENSe]:CALibration:DTF:LENGth:UNIT**Syntax**

`[[:SENSe]:CALibration:DTF:LENGth:UNIT METers|FEET`
`[[:SENSe]:CALibration:DTF:LENGth:UNIT?`

Description

Sets the length unit for DTF measurement.
 Queries the length unit for DTF measurement.

Parameter

Name	Type	Range	Default
--	Keyword	METers FEET	METers

Return Format

The query returns MET or FEET.

Example

The following command sets the length unit for DTF measurement to FEET.
`:SENSe:CALibration:DTF:LENGth:UNIT FEET`

The following query returns FEET.
`:SENSe:CALibration:DTF:LENGth:UNIT?`

[[:SENSe]:CALibration:DTF:LOSS:COAX**Syntax**

`[[:SENSe]:CALibration:DTF:LOSS:COAX <loss>`
`[[:SENSe]:CALibration:DTF:LOSS:COAX?`

Description

Sets the cable loss for DTF measurement.
 Queries the cable loss for DTF measurement.

Parameter

Name	Type	Range	Default
<loss>	Consecutive Real Number	0.00 dB/m to 5.00 dB/m	0.00 dB/m

Return Format

The query returns the cable loss in scientific notation.

Example

The following command sets the cable loss for DTF measurement to 2 dB/m.
`:SENSe:CALibration:DTF:LOSS:COAX 2`

The following query returns 2.000000000e+00.
`:SENSe:CALibration:DTF:LOSS:COAX?`

[[:SENSe]:CALibration:DTF:VELOCITY

Syntax

```
[[:SENSe]:CALibration:DTF:VELOCITY <velocity>
[:SENSe]:CALibration:DTF:VELOCITY?
```

Description

Sets the velocity factor for DTF measurement.
Queries the velocity factor for DTF measurement.

Parameter

Name	Type	Range	Default
<velocity>	Consecutive Real Number	0.1 to 1	0.66

Return Format

The query returns velocity factor for DTF measurement in scientific notation.

Example

The following command sets the velocity factor to 0.5.

```
:SENSe:CALibration:DTF:VELOCITY 0.5
```

The following query returns 5.000000000e-01.

```
:SENSe:CALibration:DTF:VELOCITY?
```

[[:SENSe]:CALibration:EXTension:DTF:LENGth:UNIT

Syntax

```
[[:SENSe]:CALibration:EXTension:DTF:LENGth:UNIT METers|FEET
[:SENSe]:CALibration:EXTension:DTF:LENGth:UNIT?
```

Description

Sets the length unit for the port extension of DTF.
Queries the length unit for the port extension of DTF.

Parameter

Name	Type	Range	Default
--	Keyword	METers FEET	METers

Return Format

The query returns MET or FEET.

Example

The following command sets the length unit for the port extension of DTF to METers.

```
:SENSe:CALibration:EXTension:DTF:LENGth:UNIT METers
```

The following query returns MET.

```
:SENSe:CALibration:EXTension:DTF:LENGth:UNIT?
```

[[:SENSe]:CALibration:EXTension:DTF:PORT1:LENGth

Syntax

```
[[:SENSe]:CALibration:EXTension:DTF:PORT1:LENGth <length>
[:SENSe]:CALibration:EXTension:DTF:PORT1:LENGth?
```

Description

Sets the length of Port 1 extension for DTF.
Queries the length of Port 1 extension for DTF.

Parameter

Name	Type	Range	Default
<length>	Consecutive Real Number	-3.00 Gm to 3.00 Gm	0.00 cm

Remarks

The unit is meter or feet, which is determined by the length unit of Port 1 extension for DTF.

Return Format

The query returns the length of Port 1 extension for DTF in scientific notation.

Example

The following command sets the length of Port 1 extension for DTF to 10 m.

```
:SENSe:CALibration:EXTension:DTF:PORT1:LENGth 10
```

The following query returns 1.000000000e+01.

```
:SENSe:CALibration:EXTension:DTF:PORT1:LENGth?
```

[:SENSe]:CALibration:EXTension:DTF:PORT1:LOSS:COAX**Syntax**

```
[ :SENSe ]:CALibration:EXTension:DTF:PORT1:LOSS:COAX <loss>
```

```
[ :SENSe ]:CALibration:EXTension:DTF:PORT1:LOSS:COAX?
```

Description

Sets the cable loss of Port 1 extension for DTF.
Queries the cable loss of Port 1 extension for DTF.

Parameter

Name	Type	Range	Default
<loss>	Consecutive Real Number	0.00 dB/m to 5.00 dB/m	0.00 dB/m

Return Format

The query returns the cable loss of Port 1 extension for DTF in scientific notation.

Example

The following command sets the cable loss of Port 1 extension for DTF to 1 dB/m.

```
:SENSe:CALibration:EXTension:DTF:PORT1:LOSS:COAX 1
```

The following query returns 1.000000000e+00.

```
:SENSe:CALibration:EXTension:DTF:PORT1:LOSS:COAX?
```

[:SENSe]:CALibration:EXTension:DTF:PORT1:TIME**Syntax**

```
[ :SENSe ]:CALibration:EXTension:DTF:PORT1:TIME <time>
```

```
[ :SENSe ]:CALibration:EXTension:DTF:PORT1:TIME?
```

Description

Sets the delay time of Port 1 extension for DTF.
Queries the delay time of Port 1 extension for DTF.

Parameter

Name	Type	Range	Default
<time>	Consecutive Real Number	-10.00 s to 10.00 s	0 s

Remarks

The unit is s.

Return Format

The query returns the delay time of Port 1 extension for DTF in scientific notation.

Example

The following command sets the delay time of Port 1 extension for DTF to 1 s.
:SENSe:CALibration:EXTension:DTF:PORT1:TIME 1

The following query returns 1.000000000e+00.
:SENSe:CALibration:EXTension:DTF:PORT1:TIME?

[[:SENSe]:CALibration:EXTension:DTF:PORT1:VELOCITY**Syntax**

[[:SENSe]:CALibration:EXTension:DTF:PORT1:VELOCITY <velocity>
[:SENSe]:CALibration:EXTension:DTF:PORT1:VELOCITY?

Description

Sets the velocity factor of Port 1 extension for DTF.
Queries the velocity factor of Port 1 extension for DTF.

Parameter

Name	Type	Range	Default
<velocity>	Consecutive Real Number	0.1 to 1	0.66

Return Format

The query returns the velocity factor of Port 1 extension for DTF in scientific notation.

Example

The following command sets the velocity factor of Port 1 extension for DTF to 0.5.
:SENSe:CALibration:EXTension:DTF:PORT1:VELOCITY 0.5

The following query returns 5.000000000e-01.
:SENSe:CALibration:EXTension:DTF:PORT1:VELOCITY?

[[:SENSe]:CALibration:EXTension:DTF:STATE**Syntax**

[[:SENSe]:CALibration:EXTension:DTF:STATE OFF|ON|0|1
[:SENSe]:CALibration:EXTension:DTF:STATE?

Description

Enables or disables the port extension for DTF.
Queries the on/off status of the port extension for DTF.

Parameter

Name	Type	Range	Default
--	Bool	OFF ON 0 1	ON 1

Return Format

The query returns 0 or 1.

Example

The following command enables the port extension for DTF.

```
:SENSe:CALibration:EXTension:DTF:STAtE ON or :SENSe:CALibration:EXTension:DTF:STAtE 1
```

The following query returns 1.

```
:SENSe:CALibration:EXTension:DTF:STAtE?
```

[[:SENSe]:CALibration:EXTension:S11:LENGth:UNIT**Syntax**

```
[[:SENSe]:CALibration:EXTension:S11:LENGth:UNIT METers|FEET
```

```
[[:SENSe]:CALibration:EXTension:S11:LENGth:UNIT?
```

Description

Sets the length unit for the port extension of S11.

Queries the length unit for the port extension of S11.

Parameter

Name	Type	Range	Default
--	Keyword	METers FEET	METers

Return Format

The query returns MET or FEET.

Example

The following command sets the length unit for the port extension of S11 to FEET.

```
:SENSe:CALibration:EXTension:S11:LENGth:UNIT FEET
```

The following query returns FEET.

```
:SENSe:CALibration:EXTension:S11:LENGth:UNIT?
```

[[:SENSe]:CALibration:EXTension:S11:PORT1:LENGth**Syntax**

```
[[:SENSe]:CALibration:EXTension:S11:PORT1:LENGth <length>
```

```
[[:SENSe]:CALibration:EXTension:S11:PORT1:LENGth?
```

Description

Sets the length of Port 1 extension for S11.

Queries the length of Port 1 extension for S11.

Parameter

Name	Type	Range	Default
<length>	Consecutive Real Number	-3.00 Gm to 3.00 Gm	0.00 cm

Remarks

The unit is meter or feet, which is determined by the length unit for the port extension of S11.

Return Format

The query returns the length of Port 1 extension for S11 in scientific notation.

Example

The following command sets the length of Port 1 extension for S11 to 10 m.

```
:SENSe:CALibration:EXTension:S11:PORT1:LENGth 10
```

The following query returns 1.000000000e+01

```
:SENSe:CALibration:EXTension:S11:PORT1:LENGth?
```

[[:SENSe]:CALibration:EXTension:S11:PORT1:LOSS:COAX**Syntax**

```
[[:SENSe]:CALibration:EXTension:S11:PORT1:LOSS:COAX <loss>
```

```
[[:SENSe]:CALibration:EXTension:S11:PORT1:LOSS:COAX?
```

Description

Sets the cable loss of Port 1 extension for S11.

Queries the cable loss of Port 1 extension for S11.

Parameter

Name	Type	Range	Default
<loss>	Consecutive Real Number	0.00 dB/m to 5.00 dB/m	0.00 dB/m

Return Format

The query returns the cable loss of Port 1 extension for S11.

Example

The following command sets the cable loss of Port 1 extension for S11 to 1 dB/m.

```
:SENSe:CALibration:EXTension:S11:PORT1:LOSS:COAX 1
```

The following query returns 1.000000000e+00.

```
:SENSe:CALibration:EXTension:S11:PORT1:LOSS:COAX?
```

[[:SENSe]:CALibration:EXTension:S11:PORT1:TIME**Syntax**

```
[[:SENSe]:CALibration:EXTension:S11:PORT1:TIME <time>
```

```
[[:SENSe]:CALibration:EXTension:S11:PORT1:TIME?
```

Description

Sets the delay time of Port 1 extension for S11.

Queries the delay time of Port 1 extension for S11.

Parameter

Name	Type	Range	Default
<time>	Consecutive Real Number	-10.00 s to 10.00 s	0 s

Remarks

The unit is s.

Return Format

The query returns the delay time of Port 1 extension for S11 in scientific notation.

Example

The following command sets the delay time of Port 1 extension for S11 to 1 s.

```
:SENSe:CALibration:EXTension:S11:PORT1:TIME 1
```

The following query returns 1.000000000e+00.
:SENSe:CALibration:EXTension:S11:PORT1:TIME?

[[:SENSe]:CALibration:EXTension:S11:PORT1:VELOCITY

Syntax

```
[[:SENSe]:CALibration:EXTension:S11:PORT1:VELOCITY <velocity>
[:SENSe]:CALibration:EXTension:S11:PORT1:VELOCITY?
```

Description

Sets the velocity factor of Port 1 extension for S11.
Queries the velocity factor of Port 1 extension for S11.

Parameter

Name	Type	Range	Default
<velocity>	Consecutive Real Number	0.1 to 1	0.66

Return Format

The query returns the velocity factor of Port 1 extension for S11 in scientific notation.

Example

The following command sets the velocity factor of Port 1 extension for S11 to 0.5.
:SENSe:CALibration:EXTension:S11:PORT1:VELOCITY 0.5

The following query returns 5.000000000e-01.
:SENSe:CALibration:EXTension:S11:PORT1:VELOCITY?

[[:SENSe]:CALibration:EXTension:S11:STATE

Syntax

```
[[:SENSe]:CALibration:EXTension:S11:STATE OFF|ON|0|1
[:SENSe]:CALibration:EXTension:S11:STATE?
```

Description

Enables or disables the port extension for S11.
Queries the on/off status of the port extension for S11.

Parameter

Name	Type	Range	Default
--	Bool	OFF ON 0 1	ON 1

Return Format

The query returns 0 or 1.

Example

The following command enables the port extension for S11.
:SENSe:CALibration:EXTension:S11:STATE ON or :SENSe:CALibration:EXTension:S11:STATE 1

The following query returns 1.
:SENSe:CALibration:EXTension:S11:STATE?

[[:SENSe]:CALibration:EXTension:S21:LENGth:UNIT

Syntax

[[:SENSe]:CALibration:EXTension:S21:LENGth:UNIT METers|FEET
[:SENSe]:CALibration:EXTension:S21:LENGth:UNIT?

Description

Sets the length unit for the port extension of S21.
Queries the length unit for the port extension of S21.

Parameter

Name	Type	Range	Default
--	Keyword	METers FEET	METers

Return Format

The query returns MET or FEET.

Example

The following command sets the length unit for the port extension of S21 to METers.
[:SENSe]:CALibration:EXTension:S21:LENGth:UNIT METers
The following query returns MET.
[:SENSe]:CALibration:EXTension:S21:LENGth:UNIT?

[[:SENSe]:CALibration:EXTension:S21:PORT1:LENGth

Syntax

[[:SENSe]:CALibration:EXTension:S21:PORT1:LENGth <length>
[:SENSe]:CALibration:EXTension:S21:PORT1:LENGth?

Description

Sets the length of Port 1 extension for S21.
Queries the length of Port 1 extension for S21.

Parameter

Name	Type	Range	Default
<length>	Consecutive Real Number	-3.00 Gm to 3.00 Gm	0.00 cm

Remarks

The unit is meter or feet, which is determined by the length unit of Port 1 extension for S21.

Return Format

The query returns the length of Port 1 extension for S21 in scientific notation.

Example

The following command sets the length of Port 1 extension for S21 to 10 m.
[:SENSe]:CALibration:EXTension:S21:PORT1:LENGth 10

The following query returns 1.000000000e+01.
[:SENSe]:CALibration:EXTension:S21:PORT1:LENGth?

[[:SENSe]:CALibration:EXTension:S21:PORT1:LOSS:COAX

Syntax

```
[[:SENSe]:CALibration:EXTension:S21:PORT1:LOSS:COAX <loss>
[:SENSe]:CALibration:EXTension:S21:PORT1:LOSS:COAX?
```

Description

Sets the cable loss of Port 1 extension for S21.
Queries the cable loss of Port 1 extension for S21.

Parameter

Name	Type	Range	Default
<loss>	Consecutive Real Number	0.00 dB/m to 5.00 dB/m	0.00 dB/m

Return Format

The query returns the cable loss of Port 1 extension for S21 in scientific notation.

Example

The following command sets the cable loss of Port 1 extension for S21 to 1 dB/m.
:SENSe:CALibration:EXTension:S21:PORT1:LOSS:COAX 1

The following query returns 1.000000000e+00.
:SENSe:CALibration:EXTension:S21:PORT1:LOSS:COAX?

[[:SENSe]:CALibration:EXTension:S21:PORT1:TIME

Syntax

```
[[:SENSe]:CALibration:EXTension:S21:PORT1:TIME <time>
[:SENSe]:CALibration:EXTension:S21:PORT1:TIME?
```

Description

Sets the delay time of Port 1 extension for S21.
Queries the delay time of Port 1 extension for S21.

Parameter

Name	Type	Range	Default
<time>	Consecutive Real Number	-10.00 s to 10.00 s	0 s

Remarks

The unit is s.

Return Format

The query returns the delay time of Port 1 extension for S21 in scientific notation.

Example

The following command sets the delay time of Port 1 extension for S21 to 1 s.
:SENSe:CALibration:EXTension:S21:PORT1:TIME 1

The following query returns 1.000000000e+00.
:SENSe:CALibration:EXTension:S21:PORT1:TIME?

[[:SENSe]:CALibration:EXTension:S21:PORT1:VELOCITY

Syntax

```
[[:SENSe]:CALibration:EXTension:S21:PORT1:VELOCITY <velocity>
[:SENSe]:CALibration:EXTension:S21:PORT1:VELOCITY?
```

Description

Sets the velocity factor of Port 1 extension for S21.
Queries the velocity factor of Port 1 extension for S21.

Parameter

Name	Type	Range	Default
<velocity>	Consecutive Real Number	0.1 to 1	0.66

Return Format

The query returns the velocity factor of Port 1 extension for S21 in scientific notation.

Example

The following command sets the velocity factor of Port 1 extension for S21 to 0.5.
[:SENSe]:CALibration:EXTension:S21:PORT1:VELOCITY 0.5

The following query returns 5.000000000e-01.
[:SENSe]:CALibration:EXTension:S21:PORT1:VELOCITY?

[[:SENSe]:CALibration:EXTension:S21:PORT2:LENGTh

Syntax

```
[[:SENSe]:CALibration:EXTension:S21:PORT2:LENGTh <length>
[:SENSe]:CALibration:EXTension:S21:PORT2:LENGTh?
```

Description

Sets the length of Port 2 extension for S21.
Queries the length of Port 2 extension for S21.

Parameter

Name	Type	Range	Default
<length>	Consecutive Real Number	-3.00 Gm to 3.00 Gm	0.00 cm

Remarks

The unit is meter or feet, which is determined by the length unit of Port 2 extension for S21.

Return Format

The query returns the length of Port 2 extension for S21 in scientific notation.

Example

The following command sets the length of Port 2 extension for S21 to 10 m.
[:SENSe]:CALibration:EXTension:S21:PORT2:LENGTh 10

The following query returns 1.000000000e+01.
[:SENSe]:CALibration:EXTension:S21:PORT2:LENGTh?

[[:SENSe]:CALibration:EXTension:S21:PORT2:LOSS:COAX

Syntax

```
:SENSe:CALibration:EXTension:S21:PORT2:LOSS:COAX <loss>
:SENSe:CALibration:EXTension:S21:PORT2:LOSS:COAX?
```

Description

Sets the cable loss of Port 2 extension for S21.
Queries the cable loss of Port 2 extension for S21.

Parameter

Name	Type	Range	Default
<loss>	Consecutive Real Number	0.00 dB/m to 5.00 dB/m	0.00 dB/m

Return Format

The query returns the cable loss of Port 2 extension for S21 in scientific notation.

Example

The following command sets the cable loss of Port 2 extension for S21 to 1 dB/m.
:SENSe:CALibration:EXTension:S21:PORT2:LOSS:COAX 1

The following query returns 1.000000000e+00.
:SENSe:CALibration:EXTension:S21:PORT2:LOSS:COAX?

[[:SENSe]:CALibration:EXTension:S21:PORT2:TIME

Syntax

```
[[:SENSe]:CALibration:EXTension:S21:PORT2:TIME <time>
[:SENSe]:CALibration:EXTension:S21:PORT2:TIME?
```

Description

Sets the delay time of Port 2 extension for S21.
Queries the delay time of Port 2 extension for S21.

Parameter

Name	Type	Range	Default
<time>	Consecutive Real Number	-10.00 s to 10.00 s	0 s

Remarks

The unit is s.

Return Format

The query returns the delay time of Port 2 extension for S21 in scientific notation.

Example

The following command sets the delay time of Port 2 extension for S21 to 1 s.
:SENSe:CALibration:EXTension:S21:PORT1:TIME 1

The following query returns 1.000000000e+00.
:SENSe:CALibration:EXTension:S21:PORT1:TIME?

[[:SENSe]:CALibration:EXTension:S21:PORT2:VELOCITY**Syntax**

```
[[:SENSe]:CALibration:EXTension:S21:PORT2:VELOCITY <velocity>
[:SENSe]:CALibration:EXTension:S21:PORT2:VELOCITY?
```

Description

Sets the velocity factor of Port 2 extension for S21.
 Queries the velocity factor of Port 2 extension for S21.

Parameter

Name	Type	Range	Default
<velocity>	Consecutive Real Number	0.1 to 1	0.66

Return Format

The query returns the velocity factor of Port 2 extension for S21 in scientific notation.

Example

The following command sets the velocity factor of Port 2 extension for S21 to 0.5.

```
:SENSe:CALibration:EXTension:S21:PORT2:VELOCITY 0.5
```

The following query returns 5.000000000e-01.

```
:SENSe:CALibration:EXTension:S21:PORT2:VELOCITY?
```

[[:SENSe]:CALibration:EXTension:S21:STATE**Syntax**

```
[[:SENSe]:CALibration:EXTension:S21:STATE OFF|ON|0|1
[:SENSe]:CALibration:EXTension:S21:STATE?
```

Description

Enables or disables the port extension for S21.
 Queries the on/off status of the port extension for S21.

Parameter

Name	Type	Range	Default
--	Bool	OFF ON 0 1	ON 1

Return Format

The query returns 0 or 1.

Example

The following command enables the port extension for S21.

```
:SENSe:CALibration:EXTension:S21:STATE ON or :SENSe:CALibration:EXTension:S21:STATE 1
```

The following query returns 1.

```
:SENSe:CALibration:EXTension:S21:STATE?
```

:INPut:IMPedance**[[:SENSe]:CORREction:IMPedance[:INPut]][:MAGNitude]****Syntax**

```
:INPut:IMPedance 50|75
:INPut:IMPedance?
```

```
[[:SENSe]:CORRection:IMPedance[:INPut][:MAGNitude] 50|75
[:SENSe]:CORRection:IMPedance[:INPut][:MAGNitude]?
```

Description

Sets the input impedance. The unit is Ω .
Queries the input impedance.

Parameter

Name	Type	Range	Default
--	Discrete	50 75	50

Remarks

If the output impedance of the system under measurement is 75 Ω , you should use a 75 Ω to 50 Ω adapter (option) supplied by RIGOL to connect the analyzer with the system under test, and then set the input impedance to 75 Ω .

Return Format

The query returns 50 or 75.

Example

The following command sets the input impedance is 75 Ω .

```
:INPut:IMPedance 75 or :SENSe:CORRection:IMPedance:INPut:MAGNitude 75
```

The following query returns 75.

```
:INPut:IMPedance? or :SENSe:CORRection:IMPedance:INPut:MAGNitude?
```

[:SENSe]:FREQuency:CENTer

Syntax

```
[[:SENSe]:FREQuency:CENTer <freq>
[:SENSe]:FREQuency:CENTer?
```

Description

Sets the center frequency.
Queries the center frequency.

Parameter

Name	Type	Range	Default
<freq>	Consecutive Real Number	(100 kHz + 5 Hz) to (Fmax - 5 Hz)	(Fmax - 10 MHz)/2

Remarks

The maximum measurement frequency Fmax is determined by the instrument model. For RSA5065N, Fmax is 6.5 GHz; for RSA5032N, Fmax is 3.2 GHz; for RSA3045N, Fmax is 4.5 GHz; for RSA3030N, Fmax is 3 GHz; for RSA3015N, Fmax is 1.5 GHz.

Return Format

The query returns the center frequency in scientific notation. The unit is Hz.

Example

The following command sets the center frequency to 1 MHz.

```
:SENSe:FREQuency:CENTer 1000000
```

The following query returns 1.000000000e+06.

```
:SENSe:FREQuency:CENTer?
```

[[:SENSe]:FREQuency:CENTer:STEP:AUTO**Syntax**

```
[[:SENSe]:FREQuency:CENTer:STEP:AUTO OFF|ON|0|1
[:SENSe]:FREQuency:CENTer:STEP:AUTO?
```

Description

Sets the CF mode.

Queries the on/off status of the CF mode.

Parameter

Name	Type	Range	Default
--	Bool	OFF ON 0 1	ON 1

Remarks

ON|1: sets the CF mode to Auto.

OFF|0: sets the CF mode to Manual.

Return Format

The query returns 0 or 1.

Example

The following command sets the CF mode to Auto.

```
:SENSe:FREQuency:CENTer:STEP:AUTO ON
```

The following query returns 1.

```
:SENSe:FREQuency:CENTer:STEP:AUTO?
```

[[:SENSe]:FREQuency:CENTer:STEP[:INCRement]**Syntax**

```
[[:SENSe]:FREQuency:CENTer:STEP[:INCRement] <freq>
[:SENSe]:FREQuency:CENTer:STEP[:INCRement]?
```

Description

Sets the CF step.

Queries the CF step.

Parameter

Name	Type	Range	Default
<freq>	Consecutive Real Number	-Fmax to Fmax	Fspan/10

Return Format

The query returns the CF step in scientific notation. The unit is Hz.

Example

The following command sets the CF step to 1 MHz.

```
:SENSe:FREQuency:CENTer STEP 1000000
```

The following query returns 1.000000000e+06.

```
:SENSe:FREQuency:CENTer STEP?
```

[[:SENSe]:FREQuency:SPAN

Syntax

```
[[:SENSe]:FREQuency:SPAN <freq>
[:SENSe]:FREQuency:SPAN?
```

Description

Sets the span.
Queries the span.

Parameter

Name	Type	Range	Default
<freq>	Consecutive Real Number	10 Hz to (Fmax - 100 kHz)	Fmax – 10 MHz

Remarks

Fmax is determined by the model. For RSA5065N, Fmax is 6.5 GHz; for RSA5032N, Fmax is 3.2 GHz; for RSA3045N, Fmax is 4.5 GHz; for RSA3030N, Fmax is 3 GHz; for RSA3015N, Fmax is 1.5 GHz.

Return Format

The query returns the span in scientific notation. The unit is Hz.

Example

The following command sets the span to 20 MHz.
:SENSe:FREQuency:SPAN 20000000

The following query returns 2.000000000e+07.
:SENSe:FREQuency:SPAN?

[[:SENSe]:FREQuency:SPAN:FULL

Syntax

```
[[:SENSe]:FREQuency:SPAN:FULL
```

Description

Sets the maximum span (full span).

[[:SENSe]:FREQuency:START

Syntax

```
[[:SENSe]:FREQuency:START <freq>
[:SENSe]:FREQuency:START?
```

Description

Sets the start frequency.
Queries the start frequency.

Parameter

Name	Type	Range	Default
<freq>	Consecutive Real Number	100 kHz to (Fmax – 10 Hz)	10 MHz

Remarks

The recommended value for the start frequency is determined by IF BW. When you select a value for IF BW, the system will automatically test the start frequency.

- If the start frequency detected is smaller than the recommended start frequency value, the

- recommended start frequency prevails.
- If the start frequency detected is greater than the recommended start frequency value, the system will take your current setting as the start frequency.

The following table shows the relationship between the recommended value and the IF BW for different measurement items.

Relationship between Recommended Start Frequency and IF BW

IF BW	S11 Start Freq	S21 Start Freq	DTF Start Freq
1 kHz	10 MHz	100 kHz	1 MHz
3 kHz	10 MHz	100 kHz	2 MHz
10 kHz	10 MHz	100 kHz	5 MHz
30 kHz	10 MHz	100 kHz	10 MHz
100 kHz	20 MHz	100 kHz	20 MHz
300 kHz	50 MHz	100 kHz	50 MHz
1 MHz	70 MHz	300 kHz	70 MHz
3 MHz	100 MHz	1 MHz	100 MHz
10 MHz	200 MHz	2 MHz	200 MHz

Return Format

The query returns the start frequency in scientific notation. The unit is Hz.

Example

The following command sets the start frequency to 100 MHz.

```
:SENSe:FREQuency:STARt 100000000
```

The following query returns 1.000000000e+08.

```
:SENSe:FREQuency:STARt?
```

[:SENSe]:FREQuency:STOP

Syntax

```
[:SENSe]:FREQuency:STOP <freq>
```

```
[:SENSe]:FREQuency:STOP?
```

Description

Sets the stop frequency.

Queries the stop frequency.

Parameter

Name	Type	Range	Default
<freq>	Consecutive Real Number	(100 kHz + 10 Hz) to Fmax	Fmax

Remarks

- Fmax is determined by the model. For RSA5065N, Fmax is 6.5 GHz; for RSA5032N, Fmax is 3.2 GHz; for RSA3045N, Fmax is 4.5 GHz; for RSA3030N, Fmax is 3 GHz; for RSA3015N, Fmax is 1.5 GHz.
- When you modify the stop frequency, the center frequency and start frequency will be modified automatically if the span remains to be unchanged.

Return Format

The query returns the stop frequency in scientific notation. The unit is Hz.

Example

The following command sets the stop frequency to 10 MHz.

```
:SENSe:FREQuency:STOP 10000000
```

The following query returns 1.000000000e+07.
:SENSe:FREQuency:STOP?

[[:SENSe]:SWEep:POINTs

Syntax

```
[[:SENSe]:SWEep:POINTs <integer>
[:SENSe]:SWEep:POINTs?
```

Description

Sets the number of sweep points.
Queries the number of sweep points.

Parameter

Name	Type	Range	Default
<integer>	Integer	101 to 10,001	S11/S21: 201

Remarks:

In DTF, the **Sweep Points** menu is grayed out and disabled. You are not allowed to set it. It will be set automatically according to the Span, Stop Distance, Velocity Factor, and etc.

Return Format

The query returns the number of sweep points in integer.

Example

The following command sets the number of sweep points to 650.
:SENSe:SWEep:POINTs 650

The following query returns 650.
:SENSe:SWEep:POINTs?

[[:SENSe]:SWEep:TIME

Syntax

```
[[:SENSe]:SWEep:TIME <time>
[:SENSe]:SWEep:TIME?
```

Description

Sets the sweep time.
Queries the sweep time.

Parameter

Name	Type	Range	Default
<time>	Consecutive Real Number	1 ms to 4,000 s	S11/S21: 1.09194 s DTF: 2.12730 s

Return Format

The query returns the sweep time in scientific notation. The unit is s.

Example

The following command sets the sweep time to 100 ms.
:SENSe:SWEep:TIME 0.1

The following query returns 1.000000000e-01.
:SENSe:SWEep:TIME?

[[:SENSe]:SWEep:TIME:AUTO

Syntax

[[:SENSe]:SWEep:TIME:AUTO OFF|ON|0|1

[[:SENSe]:SWEep:TIME:AUTO?

Description

Enables or disables the auto setting of the sweep time.

Queries whether the auto setting of the sweep time is enabled or not.

Parameter

Name	Type	Range	Default
--	Bool	OFF ON 0 1	ON 1

Remarks

ON|1: enables the auto setting of sweep time.

OFF|0: indicates manual setting of sweep time.

Return Format

The query returns 0 or 1.

Example

The following command enables the auto setting of the sweep time.

:SENSe:SWEep:TIME:AUTO ON or :SENSe:SWEep:TIME:AUTO 1

The following query returns 1.

:SENSe:SWEep:TIME:AUTO?

:SOURce Commands

Command List:

- ◆ [:SOURce\[:EXternal\]:POWER\[:LEVel\]\[:IMMediate\]\[:AMPLitude\]](#)

:SOURce[:EXternal]:POWER[:LEVel][:IMMediate][:AMPLitude]

Syntax

```
:SOURce[:EXternal]:POWER[:LEVel][:IMMediate][:AMPLitude] <ampl>
:SOURce[:EXternal]:POWER[:LEVel][:IMMediate][:AMPLitude]?
```

Description

Sets the output amplitude of the tracking generator.
Queries the output amplitude of the tracking generator.

Parameter

Name	Type	Range	Default
<ampl>	Consecutive Real Number	-40 dBm to 0 dBm	-10 dBm

Return Format

The query returns the output amplitude in scientific notation.

Example

The following command sets the output amplitude to -10 dB.
:SOURce:EXternal:POWER:LEVel:IMMediate:AMPLitude -10

The following query returns -1.000000000e+01.
:SOURce:EXternal:POWER:LEVel:IMMediate:AMPLitude?

:STATus Commands

The :STATus commands and [IEEE 488.2 Common Commands](#) are used to operate or query the status registers. The structure of the status register is shown in the following figure. The STATus commands are used to set and query the questionable status register and operation status register. IEEE488.2 common commands can be used to operate on the standard event status register and status byte register.

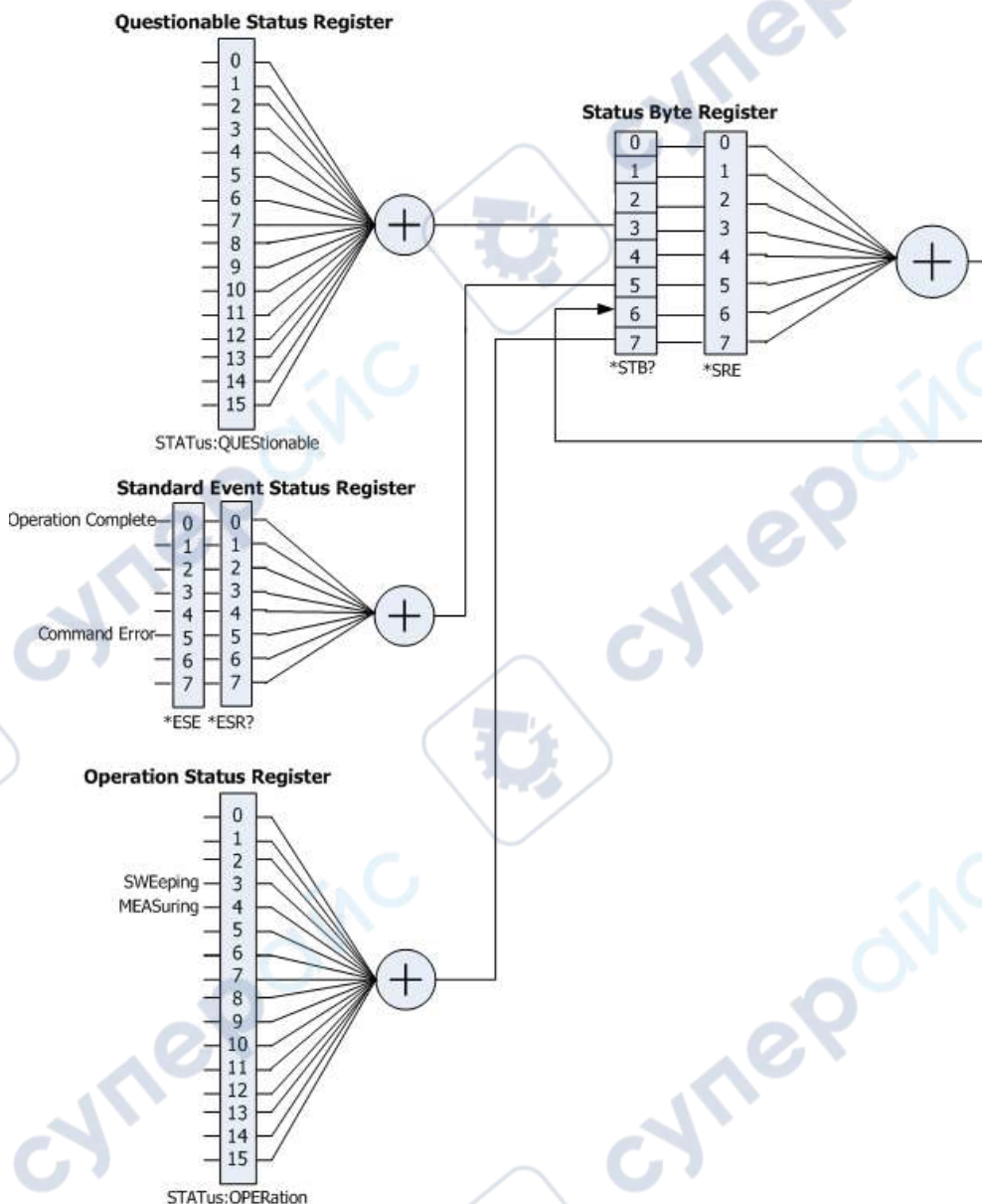

Command List:

- ◆ [:STATus:OPERation:CONDition?](#)
- ◆ [:STATus:OPERation:ENABLE](#)
- ◆ [:STATus:OPERation\[:EVENT\]?](#)
- ◆ [:STATus:PRESet](#)
- ◆ [:STATus:QUEStionable:CONDition?](#)
- ◆ [:STATus:QUEStionable:ENABLE](#)
- ◆ [:STATus:QUEStionable\[:EVENT\]?](#)

:STATus:OPERation:CONDition?

Syntax

:STATus:OPERation:CONDition?

Description

Queries the condition register of the operation status register.

Return Format

The query returns the condition register in integer. For example, 24.

:STATus:OPERation:ENABle

Syntax

:STATus:OPERation:ENABle <integer>

:STATus:OPERation:ENABle?

Description

Sets the enable register of the operation status register.

Queries the enable register of the operation status register.

Parameter

Name	Type	Range	Default
<integer>	Integer	Refer to " Remarks "	0

Remarks

The definition of the Operation Status Register is shown in the following table. Bit 0-2, bit 5-7, bit 13, and bit 14 are reserved. You can set their values but they will not affect the system. Bit 15 and bit 12-8 are not used and are always treated as 0. Therefore, the parameter <integer> can be any decimal value that corresponds to the binary-weighted sum of the bits that range from 0000000000000000 (0 in decimal) to 1111111111111111 (32,767 in decimal) and of which bit 15 and bit 12-8 are 0.

Bit	Value	Description
0	1	Reserved
1	2	Reserved
2	4	Reserved
3	8	SWEEping
4	16	MEASuring
5	32	Reserved
6	64	Reserved
7	128	Reserved
8	0	Not Used
9	0	Not Used
10	0	Not Used
11	0	Not Used
12	0	Not Used
13	8192	Reserved
14	16384	Reserved
15	0	Not Used

Return Format

The query returns the enable register of the Operation Status Register in integer.

Example

The following command sets the enable register of the Operation Status Register to 100.

```
:STATus:OPERation:ENABLE 100
```

The following query returns 100.

```
:STATus:OPERation:ENABLE?
```

:STATus:OPERation[:EVENT]?**Syntax**

```
:STATus:OPERation[:EVENT]?
```

Description

Queries the event register of the Operation Status Register.

Return Format

The query returns the event register in integer. For example, 24.

:STATus:PRESet**Syntax**

```
:STATus:PRESet
```

Description

Clears the enable register of the Operation Status Register and Questionable Status Register.

:STATus:QUESTionable:CONDition?**Syntax**

```
:STATus:QUESTionable:CONDition?
```

Description

Queries the condition register of the Questionable Status Register.

Return Format

Queries the condition register of the questionable status register in integer. For example, 0.

:STATus:QUESTionable:ENABLE**Syntax**

```
:STATus:QUESTionable:ENABLE <integer>
```

```
:STATus:QUESTionable:ENABLE?
```

Description

Sets the enable register of the Questionable Status Register.

Queries the enable register of the Questionable Status Register.

Parameter

Name	Type	Range	Default
<integer>	Integer	Refer to "Remarks"	0

Remarks

The definition of the Questionable Status Register is shown in the following table. Bit 0-8, bit 13, and bit 14 are reserved. You can set their values but they will not affect the system. Bit 15, bit 12-9 are not used and they are always treated as 0. Therefore, the parameter <integer> can be any decimal value that corresponds to the binary-weighted sum of the bits that range from 0000000000000000 (0 in decimal) to 1111111111111111 (32,767 in decimal) and of which bit 15 and bit 12-9 are 0.

Bit	Value	Description
0	1	Reserved
1	2	Reserved
2	4	Reserved
3	8	Reserved
4	16	Reserved
5	32	Reserved
6	64	Reserved
7	128	Reserved
8	256	Reserved
9	0	Not Used
10	0	Not Used
11	0	Not Used
12	0	Not Used
13	8192	Reserved
14	16384	Reserved
15	0	Not Used

Return Format

Queries the enable register of the questionable status register in integer.

Example

The following command sets the enable register of the Questionable Status Register to 100.

```
:STATus:QUESTionable:ENABle 100
```

The following query returns 100.

```
:STATus:QUESTionable:ENABle?
```

:STATus:QUESTionable[:EVENT]?**Syntax**

```
:STATus:QUESTionable[:EVENT]?
```

Description

Queries the event register of the Questionable Status Register.

Return Format

Queries the event register of the Questionable Status Register in integer. For example, 0.

:SYSTem Commands

Command List:

- ◆ [:SYSTem:BEEPer:STATe](#)
- ◆ [:SYSTem:COMMunicate:LAN\[:SELF\]:APPLy](#)
- ◆ [:SYSTem:COMMunicate:LAN\[:SELF\]:AUToip:STATe](#)
- ◆ [:SYSTem:COMMunicate:LAN\[:SELF\]:DHCP:STATe](#)
- ◆ [:SYSTem:COMMunicate:LAN\[:SELF\]:IP:ADDResS](#)
- ◆ [:SYSTem:COMMunicate:LAN\[:SELF\]:IP:DNSBack](#)
- ◆ [:SYSTem:COMMunicate:LAN\[:SELF\]:IP:DNSPreferred](#)
- ◆ [:SYSTem:COMMunicate:LAN\[:SELF\]:IP:DNSServer](#)
- ◆ [:SYSTem:COMMunicate:LAN\[:SELF\]:IP:GATeway](#)
- ◆ [:SYSTem:COMMunicate:LAN\[:SELF\]:IP:SUBMask](#)
- ◆ [:SYSTem:COMMunicate:LAN\[:SELF\]:MANuip:STATe](#)
- ◆ [:SYSTem:COMMunicate:LAN\[:SELF\]:MDNS:STATe](#)
- ◆ [:SYSTem:COMMunicate:LAN\[:SELF\]:RESet](#)
- ◆ [:SYSTem:CONFigure:INFormation?](#)
- ◆ [:SYSTem:DATE](#)
- ◆ [:SYSTem:FSWitch\[:STATe\]](#)
- ◆ [:SYSTem:LANGuage](#)
- ◆ [:SYSTem:LKEY](#)
- ◆ [:SYSTem:OPTion:STATe?](#)
- ◆ [:SYSTem:PON:TYPE](#)
- ◆ [:SYSTem:PRESet](#)
- ◆ [:SYSTem:PRESet:SAVE](#)
- ◆ [:SYSTem:PRESet:TYPE](#)
- ◆ [:SYSTem:PRESet:USER:SAVE](#)
- ◆ [:SYSTem:SCPI:DISPlay](#)
- ◆ [:SYSTem:SECurity:CLEar](#)
- ◆ [:SYSTem:SHOW](#)
- ◆ [:SYSTem:TIME](#)

:SYSTem:BEEPer:STATe

Syntax

```
:SYSTem:BEEPer:STATe OFF|ON|0|1
:SYSTem:BEEPer:STATe?
```

Description

Turns on or off the beeper.
Queries the on/off status of the beeper.

Parameter

Name	Type	Range	Default
--	Bool	OFF ON 0 1	OFF 0

Return Format

The query returns 0 or 1.

Example

The following command turns on the beeper.
:SYSTem:BEEPer:STATe ON or :SYSTem:BEEPer:STATe 1

The following query returns 1.
:SYSTem:BEEPer:STATe?

:SYSTem:COMMunicate:LAN[:SELF]:APPLY

Syntax

```
:SYSTem:COMMunicate:LAN[:SELF]:APPLY
```

Description

Applies the LAN interface parameter settings.

:SYSTem:COMMunicate:LAN[:SELF]:AUTOip:STATe

Syntax

```
:SYSTem:COMMunicate:LAN[:SELF]:AUTOip:STATe OFF|ON|0|1
:SYSTem:COMMunicate:LAN[:SELF]:AUTOip:STATe?
```

Description

Enables or disables the auto IP setting mode.
Queries the status of the auto IP setting mode.

Parameter

Name	Type	Range	Default
--	Bool	OFF ON 0 1	OFF 0

Remarks

The analyzer attempts to acquire the IP address configuration according to the sequence of DHCP, Auto IP, and Manual IP. These three modes cannot be disabled at the same time.

ON|1: enables the auto IP mode.

OFF|0: disables the auto IP mode and selects DHCP configuration mode.

Return Format

The query returns 0 or 1.

Example

The following command enables the auto IP setting mode.

```
:SYSTem:COMMunicate:LAN:SELF:AUTOip:STATe ON or :SYSTem:COMMunicate:LAN:SELF:AUTOip:STATe 1
```

The following query returns 1.

```
:SYSTem:COMMunicate:LAN:SELF:AUTOip:STATe?
```

:SYSTem:COMMunicate:LAN[:SELF]:DHCP:STATe**Syntax**

```
:SYSTem:COMMunicate:LAN[:SELF]:DHCP:STATe OFF|ON|0|1
:SYSTem:COMMunicate:LAN[:SELF]:DHCP:STATe?
```

Description

Enables or disables the DHCP configuration mode.
Queries the status of the DHCP configuration mode.

Parameter

Name	Type	Range	Default
--	Bool	OFF ON 0 1	ON 1

Remarks

The analyzer attempts to acquire the IP address configuration according to the sequence of DHCP, Auto IP, and Manual IP. These three modes cannot be disabled at the same time.

ON|1: enables the DHCP configuration mode.

OFF|0: disables the DHCP configuration mode and selects the auto IP mode.

Return Format

The query returns 0 or 1.

Example

The following command enables the DHCP configuration mode.

```
:SYSTem:COMMunicate:LAN:SELF:DHCP:STATe ON or :SYSTem:COMMunicate:LAN:SELF:DHCP:STATe 1
```

The following query returns 1.

```
:SYSTem:COMMunicate:LAN:SELF:DHCP:STATe?
```

:SYSTem:COMMunicate:LAN[:SELF]:IP:ADDRess**Syntax**

```
:SYSTem:COMMunicate:LAN[:SELF]:IP:ADDRess <ip_address>
:SYSTem:COMMunicate:LAN[:SELF]:IP:ADDRess?
```

Description

Sets the IP address.
Queries the IP address.

Parameter

Name	Type	Range	Default
<ip_address>	ASCII String	Refer to "Remarks"	--

Remarks

The format of <ip_address> is "nnn.nnn.nnn.nnn". The range for the first segment (nnn) of the address is from 1 to 223 (except 127); and the range for the other three segments is from 0 to 255.

This command is only valid in manual IP setting mode.

Return Format

The query returns the current IP address in the format of "nnn.nnn.nnn.nnn".

Example

The following command sets the IP address to "172.16.3.199".

```
:SYSTEM:COMMunicate:LAN:SELF:IP:ADDRess 172.16.3.199
```

The following query returns 172.16.3.199.

```
:SYSTEM:COMMunicate:LAN:SELF:IP:ADDRess?
```

:SYSTEM:COMMunicate:LAN[:SELF]:IP:DNSBack

Syntax

```
:SYSTEM:COMMunicate:LAN[:SELF]:IP:DNSBack <ip_address>
```

```
:SYSTEM:COMMunicate:LAN[:SELF]:IP:DNSBack?
```

Description

Sets the backup address for the DNS.

Queries the backup address for the DNS.

Parameter

Name	Type	Range	Default
<ip_address>	ASCII String	Refer to "Remarks"	--

Remarks

The format of <ip_address> is "nnn.nnn.nnn.nnn". The range for the first segment (nnn) of the address is from 1 to 223 (except 127); and the range for the other three segments is from 0 to 255.

This command is only valid in manual DNS setting mode.

Return Format

The query returns the current backup DNS address in the format of "nnn.nnn.nnn.nnn".

Example

The following command sets the backup address of DNS to "172.16.2.2".

```
:SYSTEM:COMMunicate:LAN:SELF:IP:DNSBack 172.16.2.2
```

The following query returns 172.16.2.2.

```
:SYSTEM:COMMunicate:LAN:SELF:IP:DNSBack?
```

:SYSTEM:COMMunicate:LAN[:SELF]:IP:DNSPreferred :SYSTEM:COMMunicate:LAN[:SELF]:IP:DNSServer

Syntax

```
:SYSTEM:COMMunicate:LAN[:SELF]:IP:DNSPreferred <ip_address>
```

```
:SYSTEM:COMMunicate:LAN[:SELF]:IP:DNSPreferred?
```

```
:SYSTEM:COMMunicate:LAN[:SELF]:IP:DNSServer <ip_address>
```

```
:SYSTEM:COMMunicate:LAN[:SELF]:IP:DNSServer?
```

Description

Sets the preferred address for the DNS.

Queries the preferred address for the DNS.

Parameter

Name	Type	Range	Default
<ip_address>	ASCII String	Refer to "Remarks"	--

Remarks

The format of <ip_address> is "nnn.nnn.nnn.nnn". The range for the first segment (nnn) of the address is from 1 to 223 (except 127); and the range for the other three segments is from 0 to 255.

This command is only valid in manual DNS setting mode.

Return Format

The query returns the currently preferred DNS address in the format of "nnn.nnn.nnn.nnn".

Example

The following command sets the preferred DNS address to "172.16.2.2".

```
:SYSTem:COMMunicate:LAN:SELF:IP:DNSPreferred 172.16.2.2
```

```
:SYSTem:COMMunicate:LAN:SELF:IP:DNSServer 172.16.2.2
```

The following query returns 172.16.2.2.

```
:SYSTem:COMMunicate:LAN:SELF:IP:DNSPreferred?
```

```
:SYSTem:COMMunicate:LAN:SELF:IP:DNSServer?
```

:SYSTem:COMMunicate:LAN[:SELF]:IP:GATeway**Syntax**

```
:SYSTem:COMMunicate:LAN[:SELF]:IP:GATeway <ip_address>
```

```
:SYSTem:COMMunicate:LAN[:SELF]:IP:GATeway?
```

Description

Sets the default gateway.

Queries the default gateway.

Parameter

Name	Type	Range	Default
<ip_address>	ASCII String	Refer to "Remarks"	--

Remarks

The format of <ip_address> is "nnn.nnn.nnn.nnn". The range for the first segment (nnn) of the address is from 1 to 223 (except 127); and the range for the other three segments is from 0 to 255.

This command is only valid in manual IP setting mode.

Return Format

The query returns the current default gateway in the format of "nnn.nnn.nnn.nnn".

Example

The following command sets the default gateway to "172.16.3.1".

```
:SYSTem:COMMunicate:LAN:SELF:IP:GATeway 172.16.3.1
```

The following query returns 172.16.3.1.

```
:SYSTem:COMMunicate:LAN:SELF:IP:GATeway?
```

:SYSTem:COMMunicate:LAN[:SELF]:IP:SUBMask

Syntax

```
:SYSTem:COMMunicate:LAN[:SELF]:IP:SUBMask<ip_address>
:SYSTem:COMMunicate:LAN[:SELF]:IP:SUBMask?
```

Description

Sets the subnet mask.
Queries the subnet mask.

Parameter

Name	Type	Range	Default
<ip_address>	ASCII String	Refer to "Remarks"	--

Remarks

The format of <ip_address> is "nnn.nnn.nnn.nnn". The range for the first segment (nnn) is from 0 to 255. This command is only valid in manual IP setting mode.

Return Format

The query returns the current subnet mask in the format of "nnn.nnn.nnn.nnn".

Example

The following command sets the subnet mask to "255.255.255.0".
:SYSTem:COMMunicate:LAN:SELF:IP:SUBMask 255.255.255.0

The following query returns 255.255.255.0.
:SYSTem:COMMunicate:LAN:SELF:IP:SUBMask?

:SYSTem:COMMunicate:LAN[:SELF]:MANuip:STATe

Syntax

```
:SYSTem:COMMunicate:LAN[:SELF]:MANuip:STATe OFF|ON|0|1
:SYSTem:COMMunicate:LAN[:SELF]:MANuip:STATe?
```

Description

Enables or disables the manual IP setting mode.
Queries the status of the manual IP setting mode.

Parameter

Name	Type	Range	Default
--	Bool	OFF ON 0 1	OFF 0

Remarks

The analyzer attempts to acquire the IP address configuration according to the sequence of DHCP, Auto IP, and Manual IP. These three modes cannot be disabled at the same time.

ON|1: enables the manual IP mode.

OFF|0: disables the manual IP mode and selects the DHCP mode.

Return Format

The query returns 0 or 1.

Example

The following command enables the manual IP setting mode.

```
:SYSTem:COMMunicate:LAN:SELF:MANuip:STATe ON or :SYSTem:COMMunicate:LAN:SELF:MANuip:STATe
1
```

The following query returns 1.

```
:SYSTem:COMMunicate:LAN:SELF:MANuip:STATe?
```

:SYSTem:COMMunicate:LAN[:SELF]:MDNS:STATe

Syntax

```
:SYSTem:COMMunicate:LAN[:SELF]:MDNS:STATe OFF|ON|0|1
:SYSTem:COMMunicate:LAN[:SELF]:MDNS:STATe?
```

Description

Enables or disables the state of the network information sending.
Queries the on/off status of the network information sending.

Parameter

Name	Type	Range	Default
--	Bool	OFF ON 0 1	OFF 0

Remarks

ON|1: The state of the network information sending is turned on.
ON|0: The state of the network information sending is turned off.

Return Format

The query returns 0 or 1.

Example

The following command sets the state of the network information sending to "on".

```
:SYSTem:COMMunicate:LAN:SELF:MDNS:STATe ON or :SYSTem:COMMunicate:LAN:SELF:MDNS:STATe 1
```

The following query returns 1.

```
:SYSTem:COMMunicate:LAN:SELF:MDNS:STATe?
```

:SYSTem:COMMunicate:LAN[:SELF]:RESet

Syntax

```
:SYSTem:COMMunicate:LAN[:SELF]:RESet
```

Description

Resets the LAN setting: enable the DHCP, disable Auto IP and the Manual IP.

:SYSTem:CONFigure:INFormation?

Syntax

```
:SYSTem:CONFigure:INFormation?
```

Description

Queries the system information of the spectrum analyzer.

Remarks

The system information includes the model, serial number, software and hardware version number, and firmware version number.

Return Format

The query returns the system information. For example,

Model:RSA5065N
 SN: RSA5F222900001
 Main Board:00.01.03
 CPU:00.01.00
 SPU:00.01.06
 WPU:00.01.02
 BOOT:00.01.00
 OS:00.01.00
 Firmware:00.03.00

Note: When you use RSA5065-TG/RSA5032-TG, the query also returns information about "TG Board".

:SYSTem:DATE

Syntax

```
:SYSTem:DATE <year>,<month>,<day>
:SYSTem:DATE?
```

Description

Sets the date of the instrument.
 Queries the date of the instrument.

Parameter

Name	Type	Range	Default
<year>	ASCII String	2000 to 2099	--
<month>	ASCII String	01 to 12	--
<day>	ASCII String	01 to 31	--

Return Format

The query returns the current date in the format of "YYYY,MM,DD".

Example

The following command sets the date of the instrument to 2017/11/16.
 :SYSTem:DATE 2017,11,16

The following query returns 2017,11,16
 :SYSTem:DATE?

:SYSTem:FSWitch[:STATe]

Syntax

```
:SYSTem:FSWitch[:STATe] OFF|ON|0|1
:SYSTem:FSWitch[:STATe]?
```

Description

Sets the power switch on the front panel to be turned on or off.
 Queries whether the power switch on the front panel is turned on or off.

Parameter

Name	Type	Range	Default
--	Bool	OFF ON 0 1	ON 1

Return Format

The query returns 0 or 1.

Example

The following command sets the power switch on the front panel is turned off.

```
:SYSTem:FSWitch:STATe OFF or :SYSTem:FSWitch:STATe 0
```

The following query returns 0.

```
:SYSTem:FSWitch:STATe?
```

:SYSTem:LANGUage**Syntax**

```
:SYSTem:LANGUage ENGLISH|CHINEse
```

```
:SYSTem:LANGUage?
```

Description

Sets the language of the instrument.

Queries the language of the instrument.

Parameter

Name	Type	Range	Default
--	Keyword	ENGLISH CHINEse	ENGLISH

Return Format

The query returns ENGL or CHIN.

Example

The following command sets the language to English.

```
:SYSTem:LANGUage ENGLISH
```

The following query returns ENGL.

```
:SYSTem:LANGUage?
```

:SYSTem:LKEY**Syntax**

```
:SYSTem:LKEY <option info>@<license info>
```

Description

Installs and activates the specified option.

Parameter

Name	Type	Range	Default
<option info>	ASCII String	--	--
<license info>	ASCII String	--	--

Remarks

The parameter <option info> indicates the order number of the option. <license info> indicates the serial number of the option.

Example

The following command installs the option RSA5000-PA.

```
:SYSTem:LKEY
```

RSA5000-PA@8AD12B8EBC5DF492D1D4289B7CBA5B6150BF6F5D752D645C36D74530B05F39B49C461B2
3A50D6C94A34E06782AC4380070B0D1A86BA84E02768391FFD70C2103

:SYSTem:OPTion:STATe?

Syntax

:SYSTem:OPTion:STATe? <option name>

Description

Queries whether an option is activated or not.

Parameter

Name	Type	Range	Default
<option name>	ASCII String	--	--

Return Format

The query returns 0 (not activated) or 1 (activated).

Example

The following command queries whether the option RSA5000-PA is activated.

```
:SYSTem:OPTion:STATe? RSA5000-PA
```

:SYSTem:PON:TYPE

Syntax

```
:SYSTem:PON:TYPE PRESet|LAST
```

```
:SYSTem:PON:TYPE?
```

Description

Selects the setting type the instrument recalls at power-on.

Queries what setting type the instrument recalls at power-on.

Parameter

Name	Type	Range	Default
--	Keyword	PRESet LAST	PRESet

Remarks

PRESet: indicates preset settings, including factory mode and 6 user-defined settings.

LAST: indicates the last setting.

Return Format

The query returns PRES or LAST.

Example

The following command sets the instrument to recall the last setting.

```
:SYSTem:PON:TYPE LAST
```

The following query returns LAST.

```
:SYSTem:PON:TYPE?
```

:SYSTem:PRESet

Syntax

:SYSTem:PRESet

Description

Recalls the preset settings of the system and recovers the system to the state specified by the [:SYSTem:PRESet:TYPE](#) command.

:SYSTem:PRESet:SAVE

Syntax

:SYSTem:PRESet:SAVE USER1|USER2|USER3|USER4|USER5|USER6

Description

Saves the specified user setting.

Parameter

Name	Type	Range	Default
--	Keyword	USER1 USER2 USER3 USER4 USER5 USER6	--

:SYSTem:PRESet:TYPE

Syntax

:SYSTem:PRESet:TYPE FACTory|USER1|USER2|USER3|USER4|USER5|USER6
:SYSTem:PRESet:TYPE?

Description

Selects the preset type of the system to be the factory mode or any one of the items from User1 to User6. Queries the preset type of the system.

Parameter

Name	Type	Range	Default
--	Keyword	FACTory USER1 USER2 USER3 USER4 USER5 USER6	FACTory

Return Format

The query returns FACT, USER1, USER2, USER3, USER4, USER5, or USER6.

Example

The following command sets the preset type of the system to User5.
:SYSTem:PRESet:TYPE USER5

The following query returns USER5.
:SYSTem:PRESet:TYPE?

:SYSTem:PRESet:USER:SAVE

Syntax

:SYSTem:PRESet:USER:SAVE

Description

Saves the current user setting.

Remarks

If the current preset type is "FACTory", save the current user setting to User1. If the current preset type is "User1 through User6", save the current user setting to the specified user.

:SYSTem:SCPI:DISPlay**Syntax**

```
:SYSTem:SCPI:DISPlay OFF|ON|0|1
:SYSTem:SCPI:DISPlay?
```

Description

Enables or disables the SCPI display.
Queries the setting status of the SCPI display.

Parameter

Name	Type	Range	Default
--	Bool	OFF ON 0 1	OFF 0

Remarks

When you use the SCPI commands to control the instrument remotely, turning on the SCPI Display will go to the specified menu of the corresponding command; turning off the SCPI Display will not go to the specified menu.

Return Format

The query returns 0 or 1.

Example

The following command enables the SCPI display.
:SYSTem:SCPI:DISPlay 1 or :SYSTem:SCPI:DISPlay ON

The following query returns 1.
:SYSTem:SCPI:DISPlay?

:SYSTem:SECurity:CLEar**Syntax**

```
:SYSTem:SECurity:CLEar
```

Description

Clears all the data that you set safely.

Remarks

Deletes all the files that you have saved, deletes all the configuration files, and executes the factory resetting operation.

:SYSTem:SHOW**Syntax**

```
:SYSTem:SHOW OFF|SYSTem|OPTion|LICense
:SYSTem:SHOW?
```

Description

Displays the system-related information.

Queries the system-related information.

Parameter

Name	Type	Range	Default
--	Keyword	OFF SYSTem OPTion LICense	OFF

Remarks

OFF: turns off the system information display.

SYSTem: displays the system information.

OPTion: displays the option information.

LICense: displays the registration information.

Return Format

The query returns OFF, SYST, OPT, or LIC.

Example

The following command displays the system information.

```
:SYSTem:SHOW SYSTem
```

The following query returns SYST.

```
:SYSTem:SHOW?
```

:SYSTem:TIME

Syntax

```
:SYSTem:TIME <hour>,<minute>,<second>
```

```
:SYSTem:TIME?
```

Description

Sets the system time of the instrument.

Queries the system time of the instrument.

Parameter

Name	Type	Range	Default
<hour>	ASCII String	00 to 23	--
<minute>	ASCII String	00 to 59	--
<second>	ASCII String	00 to 59	--

Return Format

The query returns the current system time in the format of "HH,MM,SS".

Example

The following command sets the system time to "15:10:30".

```
:SYSTem:TIME 15,10,30
```

The following query returns 15,10,30.

```
:SYSTem:TIME?
```

:TRACe Commands

Command List:

- ◆ [:TRACe<n>:DATA?](#)
- ◆ [:TRACe<n>:DATA:MEMory?](#)
- ◆ [:TRACe<n>:MATH:TYPE](#)
- ◆ [:TRACe<n>:MODE](#)
- ◆ [:TRACe<n>:TYPE](#)
- ◆ [:TRACe<n>:UPDate:STATe](#)

:TRACe<n>:DATA?

Syntax

:TRACe<n>:DATA?

Description

Queries the data of the specified trace.

Parameter

Name	Type	Range	Default
<n>	Discrete	1 2 3 4	--

Remarks

The returned value of the specified trace includes the real and imaginary parts, whatever the trace format.

Example

The following command returns the data of Trace 1 in the (Real+Imag) format, shown in the following:
(1.776848172E-03,4.068690594E-03)(2.462049746E-03,4.538272688E-03)...

```
:TRACe1:DATA?
```

:TRACe<n>:DATA:MEMory?

Syntax

:TRACe<n>:DATA:MEMory?

Description

Queries the memory data of the specified trace.

Parameter

Name	Type	Range	Default
<n>	Discrete	1 2 3 4	--

Remarks

The returned value of the specified trace includes the real and imaginary parts, whatever the trace format.

Example

The following command returns the memory data of Trace 1 in the (Real+Imag) format, shown in the following:

```
(1.776848172E-03,4.068690594E-03)(2.462049746E-03,4.538272688E-03)...
```

```
:TRACe<n>:DATA:MEMory?
```

:TRACe<n>:MATH:TYPE**Syntax**

```
:TRACe<n>:MATH:TYPE DIVide|MULTIply|SUBTract|ADD|OFF
:TRACe<n>:MATH:TYPE?
```

Description

Sets the trace math operation type.
Queries the trace math operation type.

Parameter

Name	Type	Range	Default
<n>	Discrete	1 2 3 4	--
--	Keyword	DIVide MULTIply SUBTract ADD OFF	OFF

Remarks

The trace math operation types are mutually exclusive. That is, when you apply one type of math operation to a certain trace, the last selected math operation will be disabled.

DIVide: Data/Memory, measurement data divided by data in the memory trace.

MULTIply: Data*Memory, measurement data multiplied by data in the memory trace.

SUBTract: Data – Memory, measurement data subtracted by data in the memory trace.

ADD: Data + Memory, measurement data added data in the memory trace.

OFF: disables the math function.

Return Format

The query returns DIV, MULT, SUBT, ADD, or OFF.

Example

The following command sets the trace math operation type to DIVide.

```
:TRACe1:MATH:TYPE DIVide
```

The following query returns DIV.

```
:TRACe1:MATH:TYPE?
```

**:TRACe<n>:MODE
:TRACe<n>:TYPE****Syntax**

```
:TRACe<n>:MODE WRITe|AVERAge|MAXHold|MINHold
:TRACe<n>:TYPE WRITe|AVERAge|MAXHold|MINHold
:TRACe<n>:MODE?
:TRACe<n>:TYPE?
```

Description

Sets the type of the specified trace.
Queries the type of the specified trace.

Parameter

Name	Type	Range	Default
<n>	Discrete	1 2 3 4	--
--	Keyword	WRITe AVERAge MAXHold MINHold	WRITe

Remarks

WRITe: indicates Clear Write. Set the trace data to a minimum value, and display the real-time sweep data of each point on the trace.

AVERage: indicates Average. Display an average trace, which is represented by averaging the data of each point on the trace.

MAXHold: indicates Max Hold. Maintain and display a max hold trace, which represents the maximum data value on a point-by-point basis. When a new maximum value is generated, data will be updated, and the newly updated maximum value prevails.

MINHold: indicates Min Hold. Maintain and display a min hold trace, which represents the minimum data value on a point-by-point basis. When a new minimum value is generated, data will be updated, and the newly updated minimum value prevails.

Return Format

The query returns WRIT, AVER, MAXH, or MINH.

Example

The following command sets the type of Trace 1 to Clear Write.

```
:TRACe1:MODE WRITe
:TRACe1:TYPE WRITe
```

The following command returns WRIT.

```
:TRACe1:MODE?
:TRACe1:TYPE?
```

:TRACe<n>:UPDate:STATe

Syntax

```
:TRACe<n>:UPDate:STATe OFF|ON|0|1
:TRACe<n>:UPDate:STATe?
```

Description

Enables or disables the update of the specified trace.
Queries the on/off update status of the specified trace.

Parameter

Name	Type	Range	Default
<n>	Discrete	1 2 3 4	--
--	Bool	OFF ON 0 1	ON 1

Return Format

The query returns 1 or 0.

Example

The following command enables the update of Trace 1.

```
:TRACe1:UPDate:STATe ON or :TRACe1:UPDate:STATe 1
```

The following query returns 1.

```
:TRACe1:UPDate:STATe?
```

:TRIGger Commands

Command List:

- ◆ [:TRIGger\[:SEQuence\]:ATRigger](#)
- ◆ [:TRIGger\[:SEQuence\]:ATRigger:STATe](#)
- ◆ [:TRIGger\[:SEQuence\]:EXTErnal<n>:DELAy](#)
- ◆ [:TRIGger\[:SEQuence\]:EXTErnal<n>:DELAy:STATe](#)
- ◆ [:TRIGger\[:SEQuence\]:EXTErnal<n>:SLOPe](#)
- ◆ [:TRIGger\[:SEQuence\]:HOLDoff](#)
- ◆ [:TRIGger\[:SEQuence\]:HOLDoff:STATe](#)
- ◆ [:TRIGger\[:SEQuence\]:SOURce](#)
- ◆ [:TRIGger2:MODE](#)

:TRIGger[:SEQuence]:ATRigger

Syntax

```
:TRIGger[:SEQuence]:ATRigger <time>
:TRIGger[:SEQuence]:ATRigger?
```

Description

Sets the time that the analyzer will wait for the trigger to be initiated automatically.
Queries the time that the analyzer will wait for the trigger to be initiated automatically.

Parameter

Name	Type	Range	Default
<time>	Consecutive Real Number	1 ms to 100 s	100 ms

Remarks

This command is only valid when the auto triggering function is enabled.

Return Format

The query returns the time value in scientific notation. The unit is s.

Example

The following command sets the time to 10 ms.

```
:TRIGger:SEQuence:ATRigger 0.01
```

The following query returns 1.000000000e-02.

```
:TRIGger:SEQuence:ATRigger?
```

:TRIGger[:SEQuence]:ATRigger:STATe

Syntax

```
:TRIGger[:SEQuence]:ATRigger:STATe OFF|ON|0|1
:TRIGger[:SEQuence]:ATRigger:STATe?
```

Description

Enables or disables the auto trigger function.
Queries the setting status of auto trigger function.

Parameter

Name	Type	Range	Default
--	Bool	OFF ON 0 1	OFF 0

Return Format

The query returns 1 or 0.

Example

The following command enables the auto trigger function.

```
:TRIGger:SEQuence:ATRigger:STATe ON or :TRIGger:SEQuence:ATRigger:STATe 1
```

The following query returns 1.

```
:TRIGger:SEQuence:ATRigger:STATe?
```

:TRIGger[:SEQuence]:EXTernal<n>:DELay**Syntax**

```
:TRIGger[:SEQuence]:EXTernal<n>:DELay <time>
```

```
:TRIGger[:SEQuence]:EXTernal<n>:DELay?
```

Description

Sets the delay time for the external trigger.

Queries the delay time for the external trigger.

Parameter

Name	Type	Range	Default
<n>	Discrete	1 2	--
<time>	Consecutive Real Number	0 us to 500 ms	1 μ s

Remarks

When the parameter n is set to 1, it indicates External Trigger 1; when set to 2, it indicates External Trigger 2.

This command is only valid when the external trigger delay function is enabled.

Return Format

The query returns the delay time for the external trigger in scientific notation. The unit is s.

Example

The following command sets the delay time for External Trigger 1 to 100 ms.

```
:TRIGger:SEQuence:EXTernal1:DELay 0.1
```

The following query returns 1.000000000e-01.

```
:TRIGger:SEQuence:EXTernal1:DELay?
```

:TRIGger[:SEQuence]:EXTernal<n>:DELay:STATe**Syntax**

```
:TRIGger[:SEQuence]:EXTernal<n>:DELay:STATe OFF|ON|0|1
```

```
:TRIGger[:SEQuence]:EXTernal<n>:DELay:STATe?
```

Description

Enables or disables the external trigger delay function.

Queries the setting state of the external trigger delay function.

Parameter

Name	Type	Range	Default
<n>	Discrete	1 2	--
--	Bool	OFF ON 0 1	OFF 0

Remarks

When the parameter n is set to 1, it indicates External Trigger 1; when set to 2, it indicates External Trigger 2.

Return Format

The query returns 1 or 0.

Example

The following command enables the delay function of External Trigger 1.

```
:TRIGger:SEQuence:EXTErnal1:DELAy:STATe ON or :TRIGger:SEQuence:EXTErnal1:DELAy:STATe 1
```

The following query returns 1.

```
:TRIGger:SEQuence:EXTErnal1:DELAy:STATe?
```

:TRIGger[:SEQuence]:EXTErnal<n>:SLOPe**Syntax**

```
:TRIGger[:SEQuence]:EXTErnal<n>:SLOPe POSitive|NEGative
```

```
:TRIGger[:SEQuence]:EXTErnal<n>:SLOPe?
```

Description

Sets the trigger edge for the external trigger.

Queries the trigger edge for the external trigger.

Parameter

Name	Type	Range	Default
<n>	Discrete	1 2	--
--	Keyword	POSitive NEGative	POSitive

Remarks

When the parameter n is set to 1, it indicates External Trigger 1; when set to 2, it indicates External Trigger 2.

POSitive: indicates the rising edge.

NEGative: indicates the falling edge.

Return Format

The query returns POS or NEG.

Example

The following command sets the trigger edge of External Trigger 1 to be Positive.

```
:TRIGger:SEQuence:EXTErnal1:SLOPe POSitive
```

The following query returns POS.

```
:TRIGger:SEQuence:EXTErnal1:SLOPe?
```

:TRIGger[:SEQuence]:HOLDoff

Syntax

```
:TRIGger[:SEQuence]:HOLDoff <time>
:TRIGger[:SEQuence]:HOLDoff?
```

Description

Sets the trigger holdoff time.
Queries the trigger holdoff time.

Parameter

Name	Type	Range	Default
<time>	Consecutive Real Number	0 us to 500 ms	100 ms

Remarks

This command is only valid when the trigger holdoff function is enabled.

Return Format

The query returns the trigger holdoff time in scientific notation. The unit is s.

Example

The following command sets the trigger holdoff time to 100 ms.
:TRIGger:SEQuence:HOLDoff 0.1

The following query returns 1.000000000e-01.
:TRIGger:SEQuence:HOLDoff?

:TRIGger[:SEQuence]:HOLDoff:STATe

Syntax

```
:TRIGger[:SEQuence]:HOLDoff:STATe OFF|ON|0|1
:TRIGger[:SEQuence]:HOLDoff:STATe?
```

Description

Turns on or off the trigger holdoff function.
Queries the status of the trigger holdoff function.

Parameter

Name	Type	Range	Default
--	Bool	OFF ON 0 1	OFF 0

Return Format

The query returns 1 or 0.

Example

The following command enables the trigger holdoff function.
:TRIGger:SEQuence:HOLDoff:STATe ON or :TRIGger:SEQuence:HOLDoff:STATe 1

The following query returns 1.
:TRIGger:SEQuence:HOLDoff:STATe?

:TRIGger[:SEQuence]:SOURce

Syntax

```
:TRIGger[:SEQuence]:SOURce EXTernal1|EXTernal2|IMMEDIATE
:TRIGger[:SEQuence]:SOURce?
```

Description

Sets the trigger source.
Queries the trigger source.

Parameter

Name	Type	Range	Default
--	Keyword	EXTernal1 EXTernal2 IMMEDIATE	IMMEDIATE

Remarks

EXTernal1: indicates External Trigger 1.
EXTernal2: indicates External Trigger 2.
IMMEDIATE: indicates the free-run trigger.

Return Format

The query returns EXT1, EXT2, or IMM.

Example

The following command sets the trigger source to free-run trigger.
:TRIGger:SEQuence:SOURce IMMEDIATE

The following query returns IMM.
:TRIGger:SEQuence:SOURce?

:TRIGger2:MODE

Syntax

```
:TRIGger2:MODE IN|OUT|0|1
:TRIGger2:MODE?
```

Description

Sets the interface type of External Trigger 2.
Queries the interface type of External Trigger 2.

Parameter

Name	Type	Range	Default
--	Bool	IN OUT 0 1	IN 0

Remarks

IN|0: indicates the input interface.
OUT|1: indicates the output interface.

Return Format

The query returns 0 or 1.

Example

The following command sets External Trigger 2 to be the input interface.
:TRIGger2:MODE IN

The following query returns 0.
:TRIGger2:MODE?



Chapter 3 Appendix

Appendix A: Default Settings

Sending the [*RST](#) command can restore the instrument to default settings, as shown in the table below.

Parameter Name	VNA Parameter
FREQ	
Center Freq	(Fmax – 10 MHz)/2
Start Freq	10 MHz
Stop Freq	Fmax
CF Step	Fspan/10
CF Step Mode	Auto
SPAN	
Span	Fmax – 10 MHz
AMPT	
Ref Value	When trace format is Lin Mag, Lin Mag(DTF), Log Mag, Phase, Group Delay, Real, Imaginary, Expand Phase, or Return Loss(DTF), the reference value is 0. When trace format is SWR, the reference value is 1.0. When trace format is Positive Phase, the reference value is 180. When trace format is Log Mag(DTF), the reference value is -100.
Ref Position	When trace format is Lin Mag, SWR, Lin Mag(DTF), or Log Mag(DTF), the reference position is 0. When trace format is Log Mag, Phase, Group Delay, Real, Imaginary, Expand Phase, Positive Phase, or Return Loss(DTF), the reference position is 5.
Scale/Div	When the trace format is Lin Mag(DTF), the scale/div value is 0.1. When the trace format is SWR, Smith, or Polar, the scale/div value is 1. When the trace format is Log Mag, Group Delay, Return Loss(DTF), or Log Mag(DTF), the scale/div value is 10. When the trace format is Phase, Positive Phase, or Expand Phase, the scale/div value is 90. When the trace format is Lin Mag, the scale/div value is 100. When the trace format is Real or Imaginary, the scale/div value is 200.
BW	
IF BW	1 kHz
Trigger	
Trigger Source	Free Run
Slope	POS
Delay State	Off
Delay Time	1.00000 us
Hold-off State	Off
Hold-off Time	100.000 ms
Auto Trig State	Off
Auto Trig	100.000 ms
Trace	
Selected Trace	Trace 1
Trace Type	Clear Write
Trace Update	On
Trace Display	Data
Trace Format	S11: Smith Lin/Phase S21: Log Mag DTF: Lin Mag(DTF)
Math Function	Off
Window Layout	Four Window (S11); UD Window (S21/DTF)
Meas	

Measurement Function	S11
Meas Setup (S11)	
Avg Number	100
Reference Level	0.00 dBm
Aperture Step Width	10
Port Extension	Off
Port 1 Delay	0.00 ns
Unit	meter
Port 1 Length	0.00 cm
Port 1 Velocity Factor	0.66
Port 1 Specific Loss	0.00 dB/m
Cal Kits	CK106A
Meas Setup (S21)	
Avg Number	100
Ref Value	-10.00 dBm
Aperture Step Width	10
Port Extension	Off
Unit	meter
Port 1 Delay	0.00 ns
Port 1 Length	0.00 cm
Port 1 Velocity Factor	0.66
Port 1 Specific Loss	0.00 dB/m
Port 2 Delay	0.00 ns
Port 2 Length	0.00 cm
Port 2 Velocity Factor	0.66
Port 2 Specific Loss	0.00 dB/m
Cal Kits	CK106A
Meas Setup (DTF)	
Avg Number	100
Ref Value	0.00 dBm
Port Extension	Off
Port Delay	0.00 ns
Unit	meter
Port Length	0.00 cm
Port Velocity Factor	0.66
Port Specific Loss	0.00 dB/m
Cal Kits	CK106A
Stop Distance	6.72 m
Velocity Factor	0.66
Cable Loss	0.00 dB/m
FFT Window	Rectangular
Marker	
Selected Marker	Marker 1
Marker Type	Position
Reference Marker	Marker 2
Marker Frequency	(Fmax - 10 MHz)/2
Marker Distance	3.36 m
Line State	Off
Marker Table	Off

Peak	
Cont Peak	Off
System^[1]	
Power On	Preset
Preset Type	Default
LAN Setting Mode	DHCP
HDMI Output	Off
HDMI Resolution	1280*720 60Hz
LCD Switch	On
LCD Backlight	100%
Power Switch	Default
Beep Switch	Off
SCPI Display	On
User Key	Off
Language	English

Note^[1]: Not affected by Preset settings.

Appendix B: Warranty

RIGOL TECHNOLOGIES CO., LTD. (hereinafter referred to as **RIGOL**) warrants that the product will be free from defects in materials and workmanship within the warranty period. If a product proves defective within the warranty period, **RIGOL** guarantees free replacement or repair for the defective product.

To get repair service, please contact with your nearest **RIGOL** sales or service office.

There is no other warranty, expressed or implied, except such as is expressly set forth herein or other applicable warranty card. There is no implied warranty of merchantability or fitness for a particular purpose. Under no circumstances shall **RIGOL** be liable for any consequential, indirect, ensuing, or special damages for any breach of warranty in any case.