

DC power supply

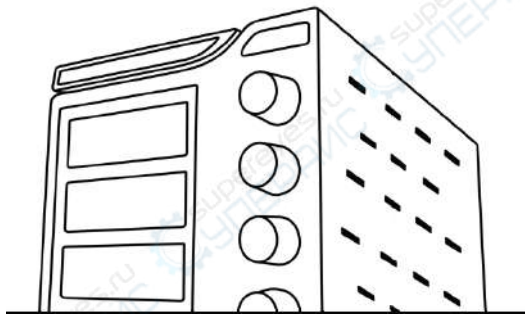

Product specifications

Table of Contents

Safety summary	1
Chapter I Overview	3
Chapter II Operating specifications	11
Chapter III Maintenance	15
Chapter IV Performance indicators	17
Chapter V Declaration of toxic and hazardous substances in the product	19
Chapter VI Warranty service	26
Warranty card	29
Attached page (305a function add-on)	30

Performance indicators are subject to change without prior notice.

Safety summary

.This section contains important safety instructions that must be followed by operating power and storage environments. In order to ensure your safety, please read the following instructions before operation to ensure that the power supply in the best working environment.

Safety guide

General



- .do not place heavy objects on the casing.
 - ...To avoid severe impact or improper disposal cause damage to the machine
 - ..Measures to prevent electrostatic discharge should be taken when connecting the instrument.
 - Do not block or isolate the fan vent.
 - Please do not open the machine unless your are a professional.
-

Power supply



- AC input voltage: 220V.10%.50Hz (110V input or 100V/220V manual switching)
- The ground wire of the source line needs to be connected to the ground to avoid electric shock

.Fuse



- Ensure to use the correct fuse model before the startup.
- ...To prevent fire, the fuse conforming to the model and rated value should be replaced.
- Before replacing the fuse, firstly cut the power to troubleshoot the causes for damaging the fuse.

Cleaning machine

- .Firstly cut the power before cleaning.
 - ...Wet the soft cloth with the warm Detergent and water. Do not spray the detergent directly.
 - do not use chemical or cleaning agent containing abrasive products, such as
-

		Benzene, toluene, xylene and acetone.
Operating environment	<ul style="list-style-type: none"> ●Applicatio place.: indoor, prevent direct sunlight, dust and strong magnetic field ● Relative humidity.: <80% ● Elevation.: <2000m ● Temperature.: 5.- 40. 	
.Storing environment	<ul style="list-style-type: none"> ● Position.: indoor ● Relative humidity.: <60% ● Temperature.: 5.- 30. 	

Chapter I Overview

This series is a single output DC regulated power supply with LED digital display. It may display voltage, current and power simultaneously. It is portable and small and the voltage and current may be adjusted continuously.

1.1 Functional features

- LED digital display may virtually display the power output voltage, current and power
- automatic switching regulator and flow regulator
- The control is more flexible with output control switch
- Over-voltage, over-current, over-power and over-temperature protection. The protection threshold may be set with the special computer software.
- The convenient and fast operation interface
- The temperature control fan speed instrument is low in noise; the fan is long in life.

- Voltage value can be set in advance under Output turn off state, which is convenient to operate

1.2. Front and rear panel

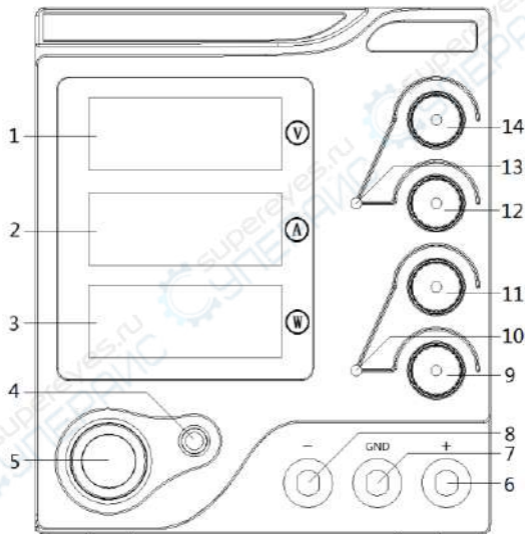

Diagram of front panel

1. Voltage display: the current output voltage (unit: V) will be displayed when opening the power output. The output status will be off when cutting down the output.

2. Current display: current output current will be displayed when opening the power output (unit A). the table of display status is shown as follows when the power supply is in the protection status (no display when cutting the power supply)

Status	Display contents
Over-voltage protection	.OVP.
Over-current protection	.OCP.
Over-power protection	.OPP.
Over-temperature protection	.OTP.

- 3. Power display:** the current output power will be displayed when opening the power output (unit: W); off. will be displayed when cutting the power output.
- 4. Output ON/OFF key:** it may directly control the power output on/off status. The green indicates the output status is on; red indicates the current output status is off.
- 5. Power switch:** it is used to open or close the power. The status is on after pressing the switch.
- 6. Output positive:** power output positive (+)
- 7. Ground terminal:** The safety ground wire terminal is connected with the power supply shell.
- 8. Output negative:** power output negative (-)
- 9. Current adjustment:** fine adjustment of the current in constant current, adjust the constant current with coarse adjusting current knob.

10. Constant current indicator: if the light is on, it indicates the power is in the steady current status.

11. Coarse adjustment of current: it is used to coarsely adjust the current upon constant current, and adjust the steady current with the fine adjustment current knob.

12. Fine adjustment of voltage: it is used to finely adjust the voltage upon constant voltage and adjust the constant voltage with the coarse adjustment voltage knob.

13. CA stabilizing pressure indicator: if the indicator is on, it indicates the power supply is in the stable voltage working status.

14. Coarse adjustment of voltage: it is used to coarsely adjust the voltage upon constant voltage and adjust the constant voltage with the fine adjustment voltage knob.

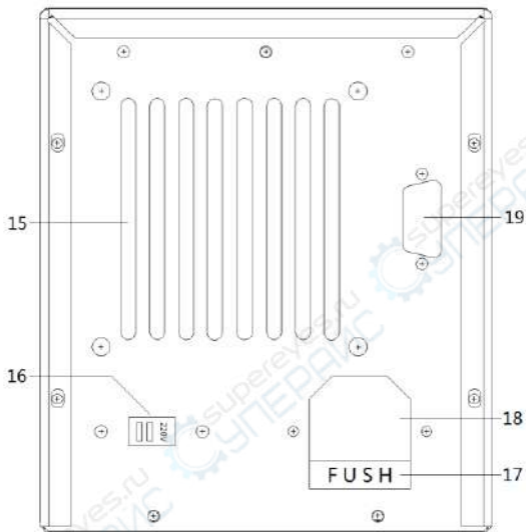

Diagram of rear panel

15. Cooling fan vent: It is used for power supply air cooling. According to current output consumption, intelligently adjust the fan speed,

effectively reduce the fan noise and prolong the fan noise.

16. Input power switch: AC110V/220V input switch (default no switch).

17. Fuse seat: the power fuse is installed inside and may be replaced with screwdriver.

18. Power input socket: AC power input

19. RS232 serial port seat: it may be communicated with the control CPU of the power supply via the interface, read the power output or set the relevant protection threshold (default no communication interface);

1.3. First use

1.3.1. Connecting power

(1) input power demand

.The details of input power should refer to chapter IV Performance Indicators.

(2) check the fuse

The proper fuse has been installed when the instrument is delivered. Please use the correct fuse model before startup.

(3) .Connect power supply line of instruments

Use the power cord supplied by the attachment to connect the instrument to the AC power supply.



In order to avoid electric shock, please confirm that the instrument has been properly grounded.

1.3.2. Power-on check

Press the power switch front panel, connect the power. The back light of .ON/OFF. key displays the red. The power output is in the off status. Press .ON/OFF. key and the back light of .ON/OFF. key displays green. The power has opened output.

Hint: please restart after shutdown. Please guarantee the interval of two startups is larger than 5s.

1.3.3. Output check

The output check may ensure the instruments to correctly respond to the operation of front panel and output the rated value. The output check includes the voltage output of channel load and the current output of short circuit.

(1) Output switch

To open the power output, press .on/off. key and the back light will turn to green. And then press the key to close the output and the back light will turn to red.

(2) voltage output check

- a. When the instrument is in empty load, open the power key and confirm the constant current of current knob is 0;

b. Press .ON/OFF. key and open the output. When the back light turns to green, the channel is in constant voltage output status (CV light is on). Check whether the voltage is adjusted to the maximum rated value from 0.

(3) Power output check

a. Open power key;

b. Adjust the power knob to make the power output voltage as 3-5V. and then press .ON/OFF. key to cut the output;

c. Use one wire to connect the output terminal of front panel;

d. Press .ON/OFF. key to open the voltage.

When the back light turns to green, the channel will be in constant current output status (CC indicator is on). Check whether the current is adjusted to the maximum rated value from 0.

Chapter II Operating specifications

Chapter II Operating specifications

2.1. Constant voltage output

The power supply provides two kinds of power output modes: constant voltage output (CV) and constant current output (CC).

Under CV mode, the output voltage will be directly controlled by two knobs of coarse and fine adjustment. Under CC mode, the output current will be controlled by two knobs of coarse and fine adjustment. For example, the voltage is set as 16V, the current is set as the maximum rated value and the access load is 8./300W. $16V/8. = 2A < \text{maximum rated value}$, so the constant voltage outputs 16v and 2A power supply.

Operation steps:

- (1) Connect the output lead: connect the instrument output terminal to the load in the mode as follows.

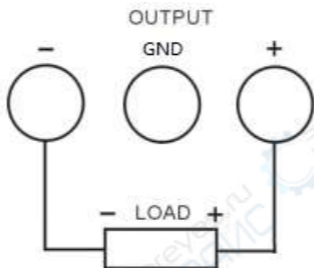

- (2) Open power supply: press the power key and the starting instrument will enter the working status.
- (3) Voltage setting: adjust two knobs of fine and coarse voltage adjustment and set the voltage as 16V.
- (4) Current setting: adjust two knobs of fine and coarse voltage adjustment to set the

constant current value as the maximum rated value.

- (5) Open output: press .ON/OFF. Key (backlight will turn green) and the instrument will work under the constant voltage output mode.

Hint: under CA mode, if the load changes cause the output current exceed the setting value, the instrument will be switched to CC mode according to the setting current, and the output voltage will be reduced proportionally. At this time, the current setting value will be increased and CV output will be recovered.

2.2. Constant current output

For example, the voltage is set as 16V. the current is set as the maximum rated value 5A (eTM-305). The access load is 1./300W. because $1..5A = 5V < 16V$ and $16V/1. = 16A > 5A$, the

channel constant current will output 5V and 5A power.

Operating steps:

- (1) Connect output lead: connect the instrument output terminal to load in the mode shown in the following figure.

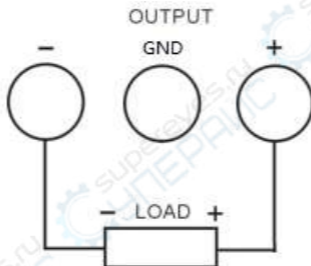

Incorrect connection may cause damage to the product or equipment connected to this product.

- (2) Open power supply: press the power key and the starting instrument will enter the working status.
- (3) Voltage setting: adjust two knobs of fine and coarse voltage adjustment and set the voltage as 16V.
- (4) Current setting: adjust two knobs of fine and coarse voltage adjustment to set the constant current value as the maximum rated value.
- (5) Open output: press .ON/OFF. Key (backlight will be green) and the instrument will work under the constant current output mode.

Hint: under CC mode, if the load changes cause the output voltage cause the setting value, the instrument will be switched to CV mode according to current voltage, and the output current will be reduced proportionally. At this

time, the voltage setting value may be increased and CC output will be recovered.

Chapter III Maintenance

3.1. Regular check

- In the product use process, in order to ensure the product to achieve the best working conditions, please do check regularly.
- Check the power supply power input socket is burned. Check the power supply output terminal is loose.

3.2. Replacement of fuse Steps

- (1) Take the power cord and take away the fuse box with a small screwdriver.

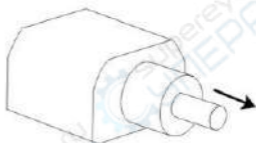
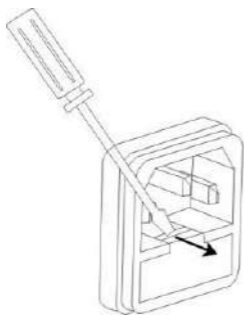

(2) Replace the fuse

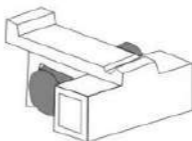
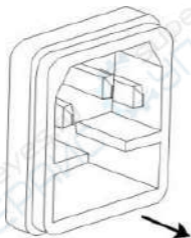

.Specifications for fuse:

220V: F5A/250V

110V: F10A/250V (F5A/250V :150W type)

Chapter IV Performance indicators

When using the specification, please ensure start up for above 10s.

4.1. Voltage output:

Output voltage: OV maximum rated voltage

Power effect: 0.1%+5mV

Load effect: 0.1%+5mV

Ripple noise: 30mVrms

4.2. Current output:

Output current: OV maximum rated voltage

Power effect: 0.01%+3mA

Load effect: 0.01%+20mA

Ripple noise: 10mArms

4.3. Display resolution

Voltage resolution: three-position: 10mV,
four-position: 1mV

Current resolution: three-position: 10mA,
four-position: 1mA

Power resolution: three-position: 10mW,
four-position: 1mW

4.4. Operating environment

. Indoor use

Elevation: .2000m

Environmental temperature: -10°C to 40°C

Relative humidity: 80%

4.5. Storage environment

Environmental temperature: -20°C to 80°C

Relative humidity: 80%

4.6. Power input

AC 220V $\pm 10\%$, 50Hz (110V input or
100V/220V manual switching)

4.7. Appendix:

Specifications	1
Qualification certificate	1
Power line	1
Clamp line	1

4.8. Product size

265(D) 125(W) 145(H) mm.

4.9. Weight

About 2kg

Chapter V Declaration of toxic and hazardous substances in the product

Part name	Toxic or hazardous substances or elements					
	(Pb) Lead	(Hg) Mercury	(Cd) Cadmium	(Cr(VI)) Six valence chromium	(PBB) Polybrominated biphenyl	(PBDE) Polybrominated Diphenyl Ethers
Printed circuit module	X	O	O	O	O	O
Transformer	X	O	O	O	O	O
Connector	X	O	O	O	O	O

ing line						
Hardwar ebox	X	O	O	O	O	O
Power line	X	O	O	O	O	O
Electric material	O	O	O	O	O	O
Rubber panel	O	O	O	O	O	O
Packing material	O	O	O	O	O	O

O: indicate the content of poisonous and harmful materials in the homogeneous materials is less than the limit specified in SJ/T11363-2006.

X: indicate the content of poisonous and harmful materials in the homogeneous materials exceeds the limit specified in SJ/T11363-2006.

Specifications: This table shows that the product may contain these substances. However, this information may be updated with the development of Technology. The causes for labeling .X.: the alternative technology and parts conforming to *Measures for the Administration of Pollution Control of Electronic Information Products* are not provided currently.

Chapter VI Warranty service

1. thank you for choosing this power. Our company will strictly implement the national .three warranty. policy. If the product quality problem is not caused by the artificial elements, you may repair, exchange or return the product against the invoice or .three warranty certificate.. If the project exceeds the warranty period, we only charge the expenses for replacing parts.

2. The following conditions are exempted from the warranty scope:

- (1) Exceeding the effective term of .three warranty.
- (2) Alter .three guarantee. certificate without authorization.
- (3) The improper use, maintenance and safeguarding of product cause the damages.
- (4) The natural disasters, grid fault or other force majeure causes the product damages.
- (5) The accessories are not in the warranty scope.
- (6) The product model or number on .three guarantee. certificate are not consistent with the physical commodity.

3. The products to be repaired should be packed and transported properly. In case of damage or missing in the transporting process, our company will not assume any responsibility.

4. The warranty card should affix the seal of after-sales unit and the date to ensure your rights.

.Warranty card

.The card is the product warranty card. Please
safe keep the card properly.

Product name (product model)	
.Purchase date	
.Sales unit	
.Customer name	
Customer address	
.Customer Tel.:	
.Fault description	

The display additional remarks of the model

305A “mA”、“mW”.The display panel add two indicator lights: include current unit “mA indicator light” and the power unit “mW indicator light” .

“mA indicator light”:when the display current less than 1 A,the light is red, and that mean the display panel numeric unit is mA.

“mW indicator light”:when the display power less than 1 Wythe light is red, and that mean the display panel numeric unit is mW.