

DC power supply

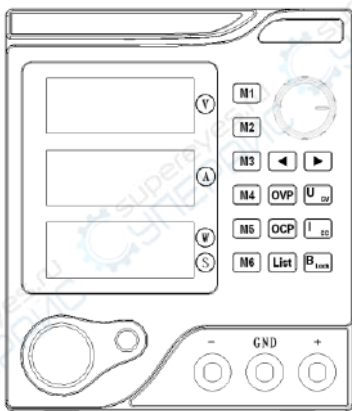

programmable power supply series product manual

Table of Contents

Safety summary.....	1
Chapter I Overview.....	3
Chapter II Operating specifications.....	11
Chapter III Maintenance.....	15
Chapter IV Performance indicators.....	17
Chapter V Declaration of toxic and hazardous substances in the product.....	19
Chapter VI Warranty service.....	20
Warranty card	22

Performance indicators are subject to change without prior notice.

Safety summary

This chapter contains important safety instructions that must be followed by operating power and storage environments. In order to ensure your safety, please read the following instructions before operation, to ensure that the power supply in the best working environment.

Safety guide

General
introduction



- Do not place heavy objects on the chassis.
 - Avoid serious impact or improper disposal, resulting in machine damage.
 - The measures to prevent electrostatic discharge should be taken when connecting instruments.
 - Do not block or isolate fan vents.
 - Do not open the machine unless it is a professional person.
-

Power
supply



- AC input voltage: 220V + 10%, 50Hz (110V input or 100V/220V manual switching)
- The grounding wire of power line should be connected to the grounding terminal to avoid electric shock.

Fuse



- Ensure the correct fuse type before starting.
- To prevent fire, replace the fuse which conforms to the model and rating.
- Cut off the power supply before replacing the fuse, and exclude the cause of the fuse damage.

Cleaning
machine

- Cut off the power before cleaning.
- Wet the soft cloth with the mild detergent and water. Do not spray the detergent directly.
- Do not use chemicals or detergents containing abrasive products, such as

	benzene, toluene, xylene and acetone.
Operating environment	<ul style="list-style-type: none"> ● Using place : indoor, prevent direct sunlight, dust and strong magnetic field. ● Relative humidity: <80% ● Altitude: <2000m ● Temperature: 5°C to 40°C
Storage environment	<ul style="list-style-type: none"> ● Position: indoor ● Relative humidity: <60% ● Temperature : 5°C to 30°C

Chapter I Overview

This series is a single output DC regulated power supply with LED digital display. It may display voltage, current and power simultaneously. It is portable and small and the voltage and current may be adjusted continuously.

1.1 Functional features

- LED digital display may virtually display the power output voltage, current and power, and decimal point automatically carry.
- Automatic switching of steady voltage and steady current.
- ON / OFF unique judgment switch
- Five powerful protection functions: over voltage, over current, over power, over temperature, short circuit
- six sets of shortcut parameter storage function
- List programmable sequence with hardware output.
- Four integral whole: Normal power supply, CNC power supply.
- Temperature control fan speed makes the instrument with noise low and fan

life longer.

- Under output shutdown state, the voltage value and current value can be set in advance, so that the operation is convenient.
- A key lock keyboard, to prevent misoperation.

1.2 Front and rear panel

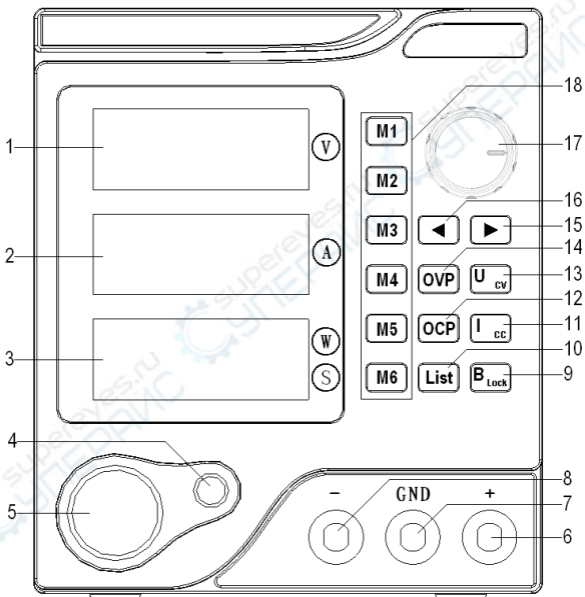

Front panel diagram

1. Voltage display: The current output voltage is displayed when the power output is turned on, unit: volts (V), and the voltage preset value is displayed when the output is turned off.

2. Current display: The current output current value is displayed when the power output is turned on, unit: Ampere (A), and the current preset value is displayed when the output is turned off.

3. Power / time / status display: The current output power value is displayed when the power output is turned on, unit: Watt (W); The time value is displayed when entering the shortcut parameter storage weaving time function, and the decimal point is fixed on the right side, unit: seconds (S); “OFF” is displayed when the power output is turned off; When the power supply enters the protection state, the status value is displayed as follows:

State	Display content
Over voltage protection	“OVP”
Over current protection	“OCP”
Over power protection	“OPP”
Over temperature protection	“OTP”

4. ON/OFF shutdown switch: It can directly control the output on-off state of power supply. Green means that the output state is open (ON); red indicates the current output state is OFF.

5. Power switch: It is used to turn on or turn off the power. The status is on after pressing the switch.

6. Output positive electrode: Power output positive (+) electrode;

7. Grounding terminal: The safety ground terminal is connected with power supply shell;

8. Output negative electrode: power output negative (-) electrode;

9. "B Lock" return / keyboard lock: under normal mode, short press to return to the main power interface; Long press 2S to lock keyboard, the operation of all function buttons of panel (excluding ON/OFF key) is invalid, at this time "B Lock" lamp is always bright.

10. "List" mode key: Long press 2S to enter or exit hardware List function mode, and "List" button light is always light under hardware List function mode; After entering the List function mode, the output turns off. When List function mode is in turn off output state, short press the shortcut key in the six sets of of "M1" to "M6" can select or delete the group shortcut parameter whether to execute loop output or not

. The corresponding button backlight of selected key parameters that need to be executed is always bright. The order in which the List output executes the shortcut parameter is the selected shortcut parameter from "M1" to "M6". Press the "ON/OFF" button to start the List function output.

11. "I CC" current setting key: In normal mode, short press to entry edit mode of setting value of power supply current, and the current data setting bit flashes. "I CC" light indicates that the current output of the power supply is in steady state;

12. "OCP" over-current setting key:

In normal mode, short press to entry edit mode of power over-current function. The data setting bit of current over-current value flicker display; in the over-current function edit mode, short

pressing this button again can switch over current function open state ON/OFF.

13. "U CV" voltage setting key: In normal mode, short press to entry edit mode of setting value of power voltage, and the current data set bit flicker display. "U CV" light indicates that the current output of the power supply is in the state of steady voltage;

14. "OVP" over-voltage setting key: In normal mode, short press to entry edit mode of power overvoltage function, and the current over-pressure data set bit flicker display; in the edit mode of overvoltage function, short press this button again, can switch over voltage function open state ON/OFF.

15. "→" Cursor right arrow key: In date editing mode, short press this button to make the flashing set bit move one bit to the right (if the

flashing set bit is already the lowest bit, it doesn't move).

16. "→" Cursor left arrow key:

In date editing mode, short press this button to make the flashing set bit move one bit to the left(if the flashing set bit is already the highest bit, it doesn't move).

17. Rotating shuttle button: In normal mode, rotating shuttle in any direction or press the button to enter into edit mode of voltage data; in editing mode of any date, the current date editing sit flicker display. After no editing operation 5S, the system automatically exits the edit mode and saves the final setting value, or through the "B Lock" button to save and exit the setting value directly.

In the data editing mode of any setting value, turn the shuttle clockwise, the value of flicker bit plus "1". If it over 10 after adding 1,

then carries to the high bit of the setting value. When the setting value exceeds the maximum rated value, the setting value is the maximum ratings.

In the data editing mode of any setting value, rotate the shuttle counter-clockwise, the value of flicker bit minus "1". If it less than zero after minus 1, then borrow bit from the high bit of the setting value. When the setting value is less than 0, the setting date is 0.

In the editing mode of shortcut parameters, press the jog key to cycle switch and edit the voltage value or current value or time value in the shortcut parameter; In the editing mode of other setting value, press the jog key, and the setting site of the date editing flash moves one bit to the left. When the blinking setting site is the highest bit of the current setting value, press this button to shift the flicker to the Lowest bit

of the current setting value, that is to say, the cycle moves.

18. "M1" ~ "M6" six sets of shortcut parameter storage key: In normal mode, short press to enter the preview / edit mode of the shortcut parameters. At this point, press the "B Lock" button to exit directly and save the settings value or after 5S no editing operation, the system timeout and quit this mode and save the setting value; Continuous short press two times, the voltage setting value and current setting value of the shortcut parameter key are set to the current output voltage and current parameter value needed by the power supply.

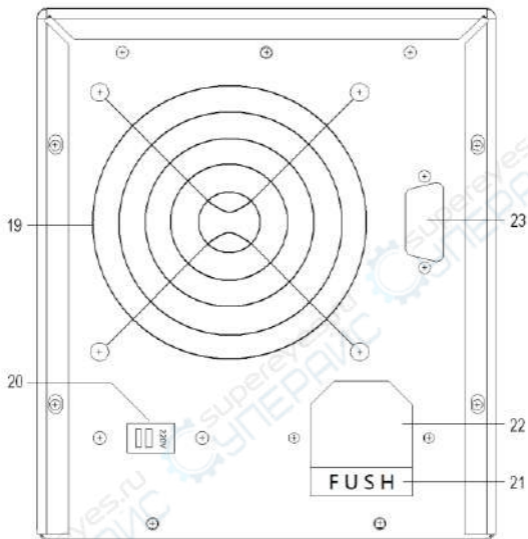

Rear panel diagram

19. Cooling fan vents:It is used for air cooling and heat dissipation of power supply. The fan speed can be intelligently adjusted according to the current output power consumption status,

which can effectively reduce the fan noise and prolong the service life of the fan.

20. Input power switch: AC110V/220V input switch (default without this switch).

21. Fuse holder: It is equipped with power fuse inside and can be prized up and replaced by a screwdriver.

22. Power input socket: AC input port.

23. RS232 serial port seat: This interface can be used to communicate with the control CPU of the power supply (default without the communication interface);

1.3 First use

1.3.1 Connect the power supply

(1) Input power requirements

Please refer to the fourth chapter performance index for details on the input power supply.

(2) Check the fuse

When the instrument is out of the factory, a suitable fuse has been installed. Make sure the correct fuse type is used before starting.

(3) Connect the instrument power cord

Please use the power line provided by the attachment to connect the instrument to the AC power supply.



In order to avoid electric shock, please confirm that the instrument has been properly grounded.

1.3.2 Battery check

Press the front panel power switch to turn on electricity. The backlight of the "ON/OFF" key displays red, and the power output is turned off. The backlight of the "ON/OFF" key displays green, and the power has turned on.

Note: if you restart after shutdown, please ensure

the two boot time interval is greater than 5S.

1.3.3 Output check

The output check ensures that the instrument can correctly respond to the front panel operation and output the rated value. The output check includes the voltage output of the channel without load and the current output during short circuit.

(1) Output switch

To turn on the power output, press the "ON/OFF" key, the back light turns green; press the key again will turn off the output, and the back lights turn red.

(2) voltage output check

- a. When the instrument is idle, turn on the power button and confirm the current setting steady current value is greater than 0V;
- b. Press the "ON/OFF" button to open the

output, until the back light becomes green, the channel is in the state of stable voltage output (CV light). Check whether the output voltage can be adjusted from 0V to maximum rating.

(3) current output check

- a. turn on the power button;
- b. Set the power supply output voltage is about 8V ;
- c. Use the output clamp wire to short circuit the front panel output terminals;
- d. Press the "ON/OFF" key to open the output, until the back light becomes green, and the channel is in the state of constant current output steady state output (CC light). Check whether the current can be adjusted from 0A to maximum rating.

Chapter II Operating specifications

2.1 Constant voltage output

The power supply provides two kinds of power output modes: constant voltage output (CV) and constant current output (CC). In the state of output cut off voltage value and current value can be set in advance. Under CV mode, the output voltage the output voltage value is set by the power supply. Under CC mode, the output current the output current value is set by the power supply. For example, the voltage is set as 16V, the current is set as the maximum rated value and the access load is $8./300W$. $16V/8. = 2A < \text{maximum rated value}$, so the constant voltage outputs 16v and 2A power supply.

Operation steps:

- (1) Connect the output lead: connect the output terminal of the instrument to the load as shown in the picture below.

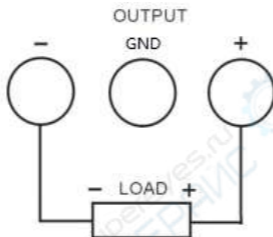

- (2) Turn on the power: Press the power button to turn on the instrument to enter the output state ("ON / OFF" button turns red).
- (3) Voltage setting: Press the "U CV" key to set the voltage to 16V.
- (4) Current setting: Press the "I CC" key to set the current value to the maximum rating.

- (5) Open the output: press the "ON/OFF" key (corresponding back light turn green), the instrument will work in the constant voltage output mode.

Note: in CV mode, if the output current exceeds the set value due to the load change, the instrument will switch to the CC mode according to the current value, and the output voltage will also be reduced proportionally. At this point, the current setting value can be increased to restore the CV output.

2.2 Constant current output

For example, the voltage is set to 16V, the current is set to 5A, and the access load is 1/300W. Because $1\Omega \times 5A = 5V < 16V$, and $16V/1\Omega = 16A > 5A$, so the constant current output are 5V、5A.

Operation steps:

- (1) Connect the output lead: connect the output terminal of the instrument to the load as shown in the picture below.

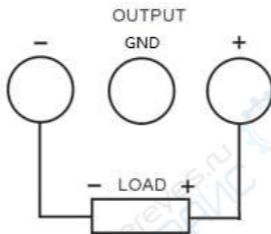

Incorrect connections may cause damage to the product or to the device connected to this product.

- (2) Turn on the power: Press the power button to turn on the instrument to enter the output state (The "ON/OFF" key back light is red).

- (3) Voltage setting: press the "U CV" key to set the voltage value to 16V.
- (4) Current setting: press the "I CC" key to set the current value to 5A.
- (5) Open the output: press the "ON/OFF" key (corresponding back light turn green), the instrument will work in the constant current output.

Note: in the CC mode, if the output voltage exceeds the set value due to the load change, the instrument will switch to the CV mode according to the current voltage value, and the output current will also be reduced proportionally. At this point, the voltage setting value can be increased to restore the CC output.

2.3 Hardware List output

For example: set the power output current value of 5A, the voltage value cycle output 6V

for 5 seconds, and then follow the 3V output voltage for 5 seconds, and then follow the 9V output voltage for 10 seconds, so output circularly the three voltages, the access load is $9/300W$, and $9V/9 = 1A < 5A$. When output circularly the voltage, the power supply is always in the state of constant voltage output. The voltage / time diagram is as follows:

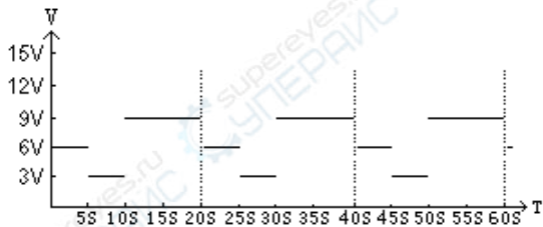

(V):Power output voltage (T) :Power operation time

Operation steps:

1. Turn on the power: Press the power button to turn on the instrument to enter the

output state (The "ON/OFF" key back light is red).

2. Press the "M1" key, turn the shuttle knob, and then with the left and right arrow keys to set the "M1" voltage value of 6V; And then press the shuttle knob to switch and edit current value, set to 5A; Press the shuttle knob to switch the editing time value, set to 5 seconds;

3. The same as step "2", setting the shortcut parameters corresponding to "M2" and "M3" respectively are (voltage value 3V, current value 5A, time value 5S), (voltage value 9V, current value 5A, time value 10S);

4. Long press the "List" mode key to enter the List edit mode, short press the "M1", "M2", "M3" key respectively to select the shortcut parameters that need to execute the loop output (The backlight of the M1-M3 key in the shortcut storage key is always bright. If there are other

shortcut parameters that their keys is always bright, then the short pressing is canceled);

5. Connecting the load, the output terminal of the instrument is connected with the load;

6. Open the output: press the "ON/OFF" key (corresponding back light turn green), the instrument will work in the hardware List output mode.

Chapter III Maintenance

3.1 Regular check

- During the use of the product, in order to ensure that the product can achieve its best working condition, please do regular inspection.
- Check if the power supply input socket is burned out. Check if the power supply output terminals are loose.

3.2 Replacement of the fuse

Steps:

- (1) Remove the power cord and remove the fuse box with a small screwdriver.

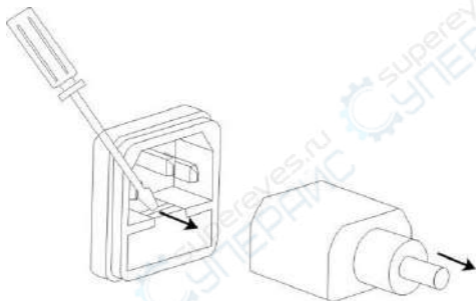

- (2) Replace the fuse.

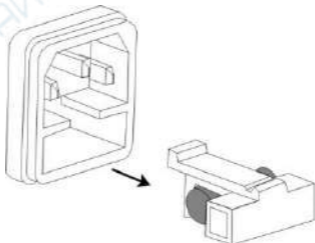

Fuse Specifications:

220V: F5A/250V

110V: F10A/250V(F5A/250V :150W model)

Chapter IV Performance indicators

When using this specification, please ensure that the boot more than 10s.

4.1 Voltage output:

Type	Program switching mode power supply	Programmable linear power supply
Output voltage	OV ~ Maximum rating	OV ~ Maximum rating
Power effect	$\leq 0.1\% + 5\text{mV}$	$\leq 0.01\% + 5\text{mV}$
Load effect	$\leq 0.1\% + 5\text{mV}$	$\leq 0.01\% + 5\text{mV}$
Ripple noise	$\leq 30\text{mVrms}$	$\leq 30\text{mVrms}$

4.2 Operating environment

Indoor use: Altitude: $\leq 2000\text{m}$

Ambient temperature: $5^{\circ}\text{C} - 40^{\circ}\text{C}$

Relative humidity: $\leq 80\%$

4.3 Storage environment

Ambient temperature: - 20 - 80°C

Relative humidity: $\leq 80\%$

4.4 Current output:

Type	Program switching mode power supply	Programmable linear power supply
Output current	OA ~ Maximum rating	OA ~ Maximum rating
Power effect	$\leq 0.1\% + 3\text{mA}$	$\leq 0.1\% + 3\text{mA}$
Load effect	$\leq 0.1\% + 20\text{mA}$	$\leq 0.02\% + 20\text{mA}$
Ripple noise	$\leq 10\text{mArms}$	$\leq 10\text{mArms}$

4.5 Display resolution

Type	Four-LED display
Voltage resolution	$< 10\text{V}: 10\text{mV}$ $\geq 100\text{V}: 0.1\text{V}$
Current	$< 10\text{A}: 1\text{mA}$

resolution	$\geq 10\text{A}$: 10mA
Power	$< 10\text{W}$: 1mW
resolution	$\geq 10\text{W}$: 10mW
	$\geq 100\text{W}$: 0.1W

4.6 Power input

AC220V \pm 10%, 50/60Hz (Or AC110V input or AC100V/220V manual switching)

4.7 Appendix:

Instructions	1
Qualification certificate	1
Power line	1
Clamp line	1
Serial Port Line	1

(Selection of model with communication interface)

4.8 Product size:

280(D) \times 130(W) \times 165(H)mm

4.9 Weight:

Type	Program switching mode power supply	Programmable linear power supply
Net weight	About 2 Kg	About 4.5 Kg

Chapter V Declaration of toxic and hazardous substances in products

Part name	Toxic and hazardous substances or elements in products					
	Lead(Pb)	Mercury(Hg)	Cadmium(Cd)	Hexavalent chromium(Cr(VI))	Polybrominated biphenyls(PBB)	Polybrominated diphenyl ethers (PBDE)
Printed circuit assembly	X	O	O	O	O	O

Transformer	X	O	O	O	O	O
Connecting line	X	O	O	O	O	O
DVB	X	O	O	O	O	O
Power line	X	O	O	O	O	O
Electronic materials	O	O	O	O	O	O
Plastic panel	O	O	O	O	O	O
Packing material	O	O	O	O	O	O

O: indicates that the contents of the toxic and hazardous substances in all homogeneous materials of this component are below the limit specified by SJ/T11363-2006 standard.

X: indicates that the toxic and hazardous substances at least one homogeneous material in the component exceed the limit specified by the SJ/T11363-2006 standard.

Specifications: This table shows that the product may contain these substances. However, this information may be updated with the development of Technology. The causes for labeling .X.: the alternative technology and parts conforming to *Measures for the Administration of Pollution Control of Electronic Information Products* are not provided currently.

Chapter VI Warranty service

1. Thank you for choosing this power. Our company will strictly implement the national .three warranty. policy. If the product quality problem is not caused by the artificial elements, you may repair, exchange or return the product with the invoice or three warranty certificate. If the

project exceeds the warranty period, we only charge the expenses for replacing parts.

2. Please pack the product carefully when send to fix the product. If the product are damaged or lost during shipment, the company will not be responsible for it.

3. The warranty card must make the after-sale unit stamp and mark the date to ensure your rights and interests.

4. The following conditions are exempted from the warranty scope:

- (1) Exceeding the effective term of three warranty.
- (2) Alter three guarantee certificate without authorization.

- (3) The improper use, maintenance and safeguarding of product cause the damages.
- (4) The natural disasters, grid fault or other force majeure causes the product damages.
- (5) The accessories are not in the warranty scope.
- (6) The product model or number on .three guarantee. certificate are not consistent with the physical commodity.

Warranty card

This card is a product warranty certificate, so please keep it well.

Product Name (Product Model)	
Purchase date	
Selling unit	
Customer name	
Customer address	
Customer phone	
Fault description	

Note: within 12 months of warranty to enjoy free warranty service (excluding accessories). The person who sends will pay the freight (only mainland customers).