

For more add-on packs please visit:

<http://learn.makeblock.com/en/mbot-add-on-packs/>

For more information, please scan the QR code
bellow with your smart device:



Six-Legged Robot

**If you have any questions or concerns about our products,
please do not hesitate to contact us!**

Makeblock Co., Ltd.

Technical support: www.makeblock.com/support

Tel: +86(0)755-26392228

Address: 4th Floor, Building C3, Nanshan iPark, No.1001 Xueyuan Avenue,
Nanshan District, Shenzhen, Guangdong Province, China 518055



+Makeblock



@Makeblock



@Makeblock

Index

mBot Add-on Pack Contents (1:1)	02
Construction Knowledge for the add-on pack	03
Six-Legged Robot - Beetle	06
Six-legged Robot - Mantis	19
Six-legged Robot - Crazy Frog	26

mBot Add-on Pack Contents (1:1)



M4 Nut



M4 Lock Nut



Plastic Spacer 4x7x3mm

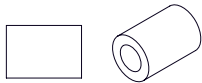

Plastic Spacer 4x7x10mm



Plastic Rivet



M4x8mm Screw

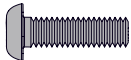

M4x14mm Screw

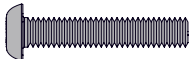

M4x22mm Screw



M4x30mm Screw



M4x35mm Screw



Any unknown parts can be checked here.

Construction Knowledge for the add-on pack

Control with App:

Makeblock App have added new control panels for Six-Legged Robot, so now you can control your Six-Legged Robot more quickly. To download Makeblock App please visit:

<http://learn.makeblock.com/en/makeblock-app/>

Construction Knowledge:

This add-on pack mainly consist of Beam0412 which is ideally for linkage structures building. Works with program and motion system, linkage structure that can create various interesting applications or awesome projects.

The construction includes some basic knowledges, get started here for skills if you are new for robots building.

How to use screwdriver and wrench:

NOTE: Screwdriver is not included in this add-on pack.



Tip

The small end of wrench is for nuts to fix motors to mBot. Please ensure to tighten the motors to your mBot.

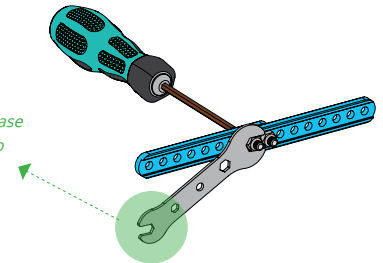

How to extend structure parts:

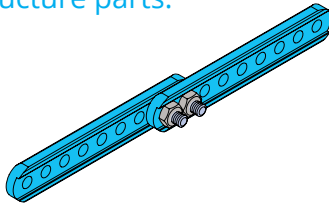

How to build motion parts with lock nuts (hinges):

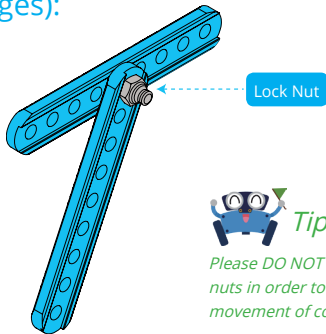

Tip

Please **DO NOT** over-torque lock nuts in order to ensure smooth movement of components

How to use plastic spacer:

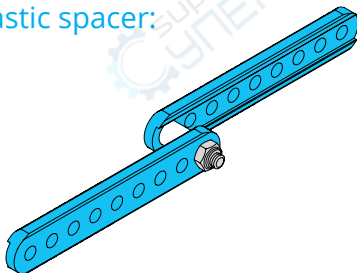

How to build motion parts with rivets:

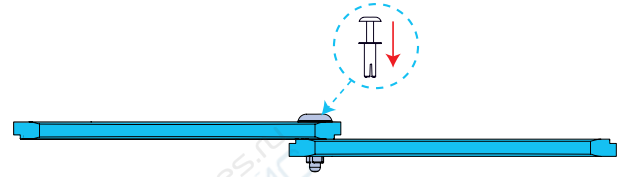

Tip

Skillful use of rivets could speed up your building, while lock nuts are better for reliability.

How to disassemble rivets:

Step 1: Push out the rivet with wrench body.

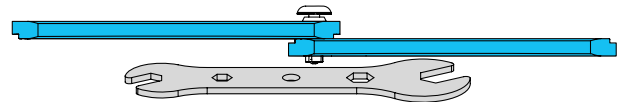

Step 2: Pull out the rivet from threaded hole with open end of wrench

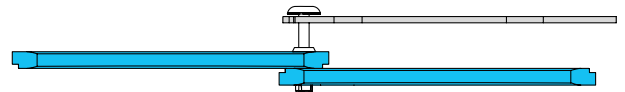

Six-Legged Robot - Beetle

mBot Class mBot Add-On Pack

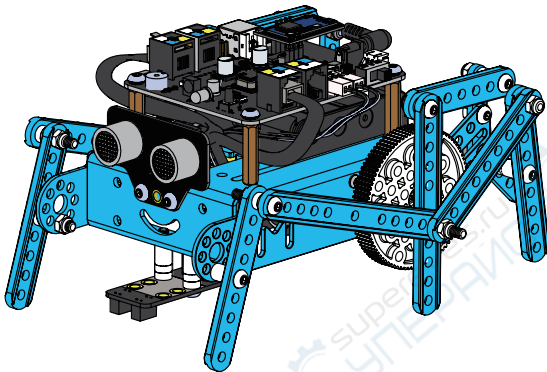

Six-Legged Robot - Beetle

Six-Legged Robot - Beetle

If your mBot already has an mCore case, please keep it for later construction.

Step 1

We default here to begin with a completed mBot built already. Please disassemble the front wheel, Me Line-follower Sensor, wheels and tires for later construction

Plastic Spacer 4×7×10mm	×2
Plastic Spacer 4×7×3mm	×4
M4×22mm Screw	×2
Me Line-follower Sensor	×1

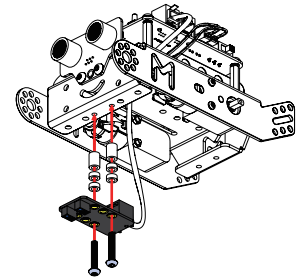

Step 2

Now let's build the left side of six-legged Beetle.

Plastic Spacer 4×7×10mm	×1
Beam 0412-076-Blue	×1
M4×22mm Screw	×1
M4 Lock Nut	×1

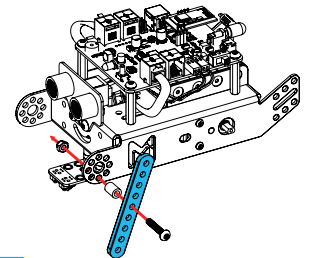

Tip
Beam 0412-076-Blue means
the beam dimension is
4mm x 12mm x 76 mm
(similarly hereinafter)

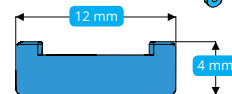

Step 3

M4×8mm Screw	×2
M4 Nut	×2
Plate 45°-Blue	×1

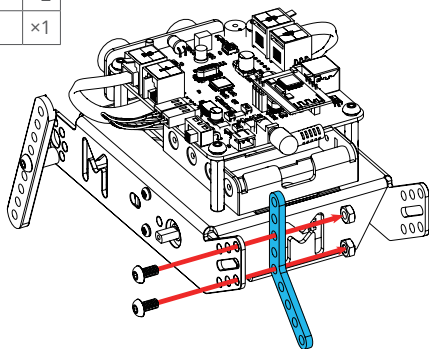

Step 4

Beam 0412-060-Blue	×1
M4×22mm Screw	×1
Plastic Spacer 4×7×10mm	×1
M4 Lock Nut	×1

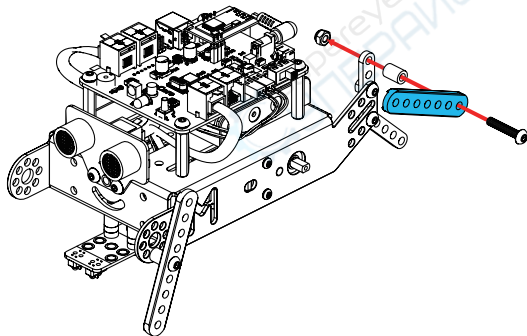

Step 5

This is the front view of wheel, please insert screw through the hole marked red.

M4×30mm Screw	×1
Beam 0412-092-Blue	×1

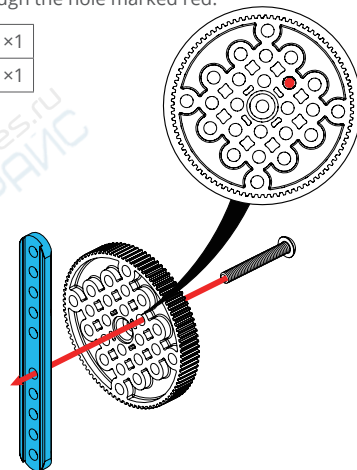

Step 6

Beam 0412-108-Blue	×1
--------------------	----

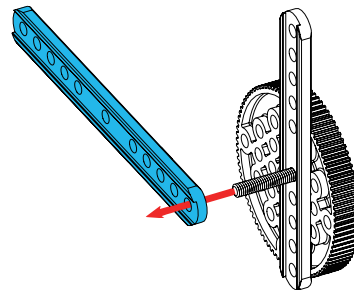

Step 7

M4 Lock Nut	×1
Beam 0412-076-Blue	×1

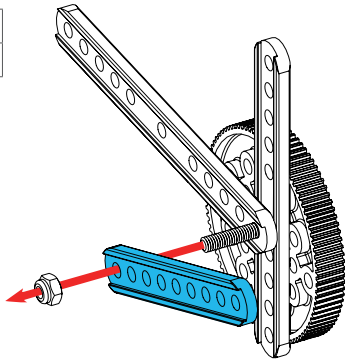

Step 8

Plastic Spacer 4×7×3mm	×1
M4×14mm Screw	×1
Beam 0412-076-Blue	×1
M4 Lock Nut	×1

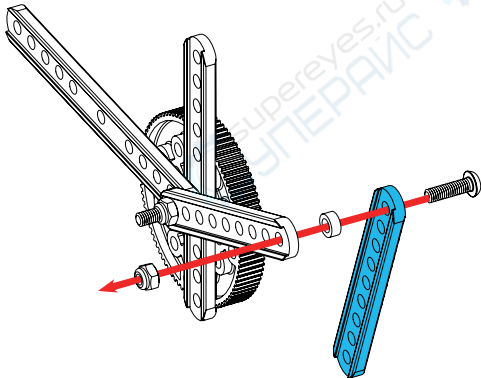

Step 9

Please fix the self-drilling screw on motor through the center of wheel. The self-drilling screw here is the M2.2 x 9mm self-drilling screw of mBot.

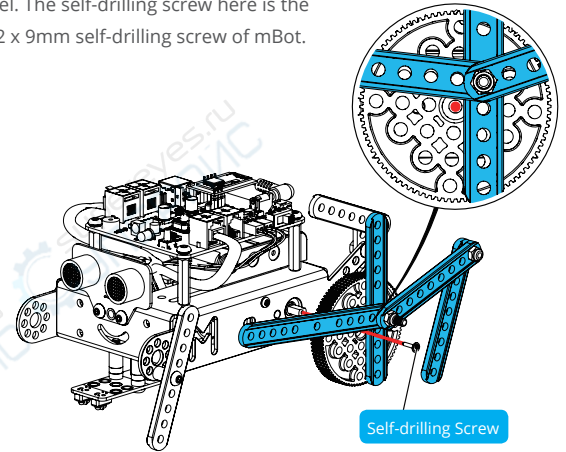

Step 10

Plastic Spacer 4×7×10mm	×1
M4×35mm Screw	×1
M4 Lock Nut	×1

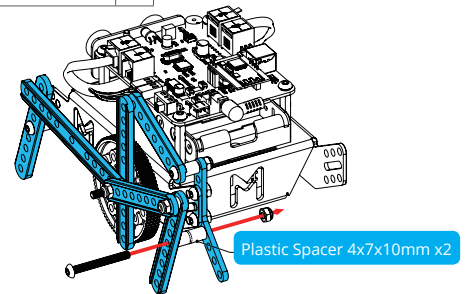

Step 11

Plastic Spacer 4×7×3mm	×1
M4×14mm Screw	×1
M4 Lock Nut	×1

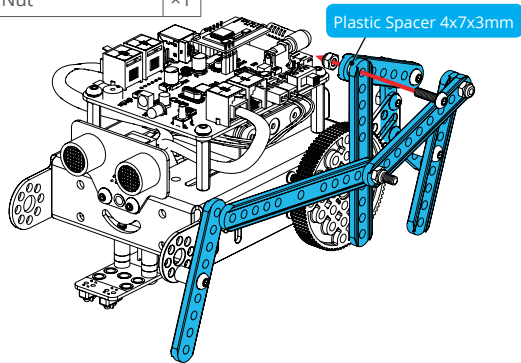

Step 12

Plastic Spacer 4×7×3mm	×2
M4×22mm Screw	×1
M4 Lock Nut	×1

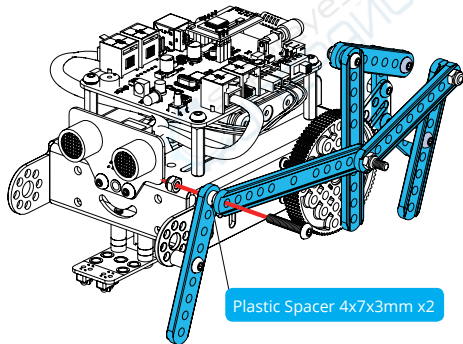

Step 13

Now let's build the right side of Beetle.

Plastic Spacer 4×7×10mm	×1
Beam 0412-076-Blue	×1
M4×22mm Screw	×1
M4 Lock Nut	×1

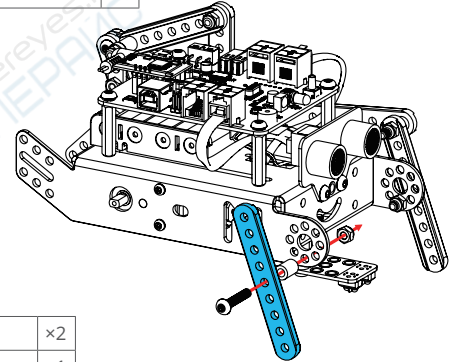

Step 14

M4×8mm Screw	×2
Plate 45°-Blue	×1
M4 Nut	×2

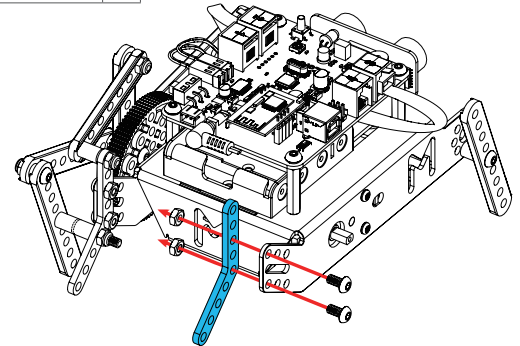

Step 15

Plastic Spacer 4×7×10mm	×1
M4×22mm Screw	×1
Beam 0412-060-Blue	×1
M4 Lock Nut	×1

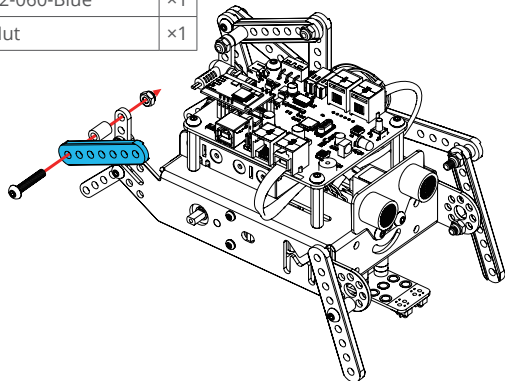

Step 17

Beam 0412-108-Blue	×1
--------------------	----

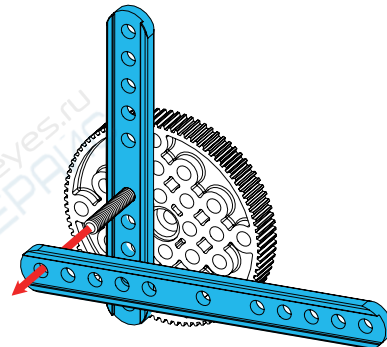

Step 16

This is the front view of wheel , please insert screw through the hole marked red.

M4×30mm Screw	×1
Beam 0412-092-Blue	×1

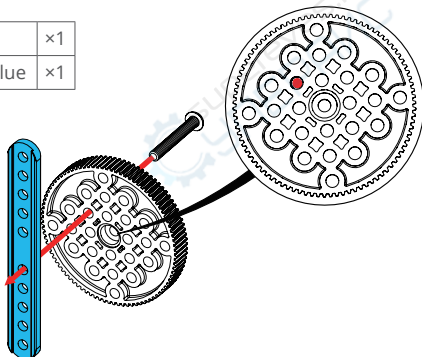

Step 18

M4 Lock Nut	×1
Beam 0412-076-Blue	×1

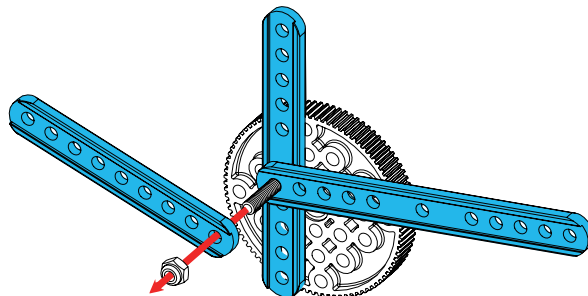

Step 19

Plastic Spacer 4×7×3mm	×1
M4×14mm Screw	×1
Beam 0412-076-Blue	×1
M4 Lock Nut	×1

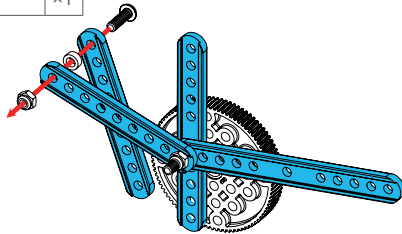

Step 20

Please fix the self-drilling screw on motor through the center of wheel. The self-drilling screw here is the M2.2 x 9mm self-drilling screw of mBot.

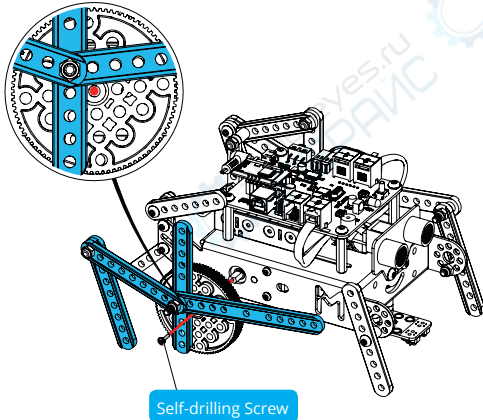

Step 21

Plastic Spacer 4×7×10mm	×2
M4×35mm Screw	×1
M4 Lock Nut	×1

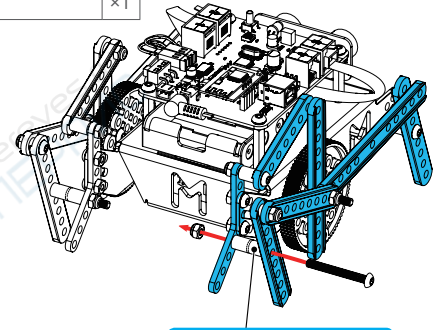

Plastic Spacer 4x7x10mm x2

Step 22

Plastic Spacer 4×7×3mm	×1
M4×14mm Screw	×1
M4 Lock Nut	×1

Plastic Spacer 4x7x3mm

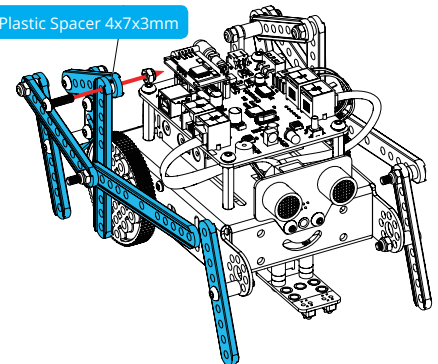

Step 23

Plastic Spacer 4×7×3mm	×2
M4×22mm Screw	×1
M4 Lock Nut	×1

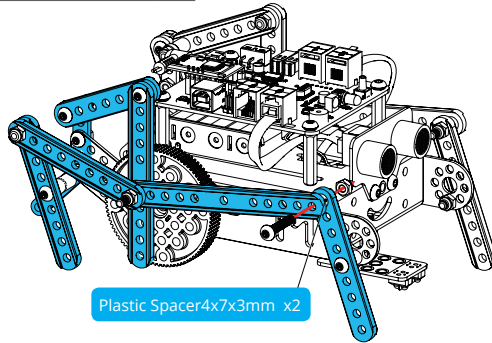

Good job !

You have finished the construction. Now you can control your Beetle according to the constructions on page 3.

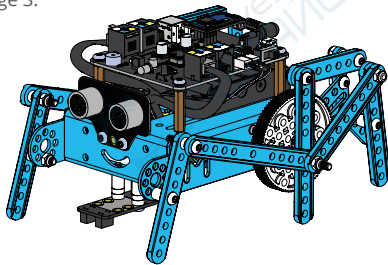

Six-Legged Robot - Mantis

mBot Class mBot Add-On Pack

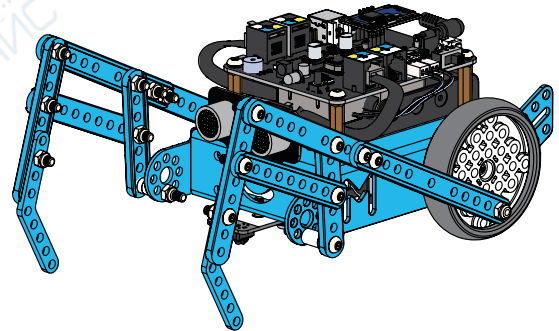

Six-Legged Robot - Mantis

Six-Legged Robot - Mantis

If your mBot already has an mCore case, please keep it for later construction.

Step 1

We default here to begin with a completed mBot built already. Please disassemble and keep the wheels and tires for later construction.

M4×22mm Screw	×1
Plastic Spacer 4×7×3mm	×2
M4 Lock Nut	×1
Beam 0412-108-Blue	×1

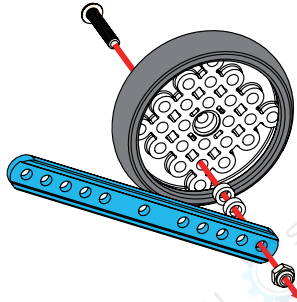

Step 2

M4×14mm Screw	×3
M4 Lock Nut	×1
M4 Nut	×2
Beam 0412-092-Blue	×1
Beam 0412-060-Blue	×1

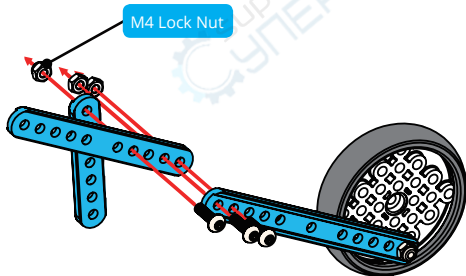

Step 3

Please fix the self-drilling screw on motor through the center of wheel. The self-drilling screw here is the M2.2 x 9mm self-drilling screw of mBot.

Plastic Spacer 4×7×10mm	×1
Plastic Spacer 4×7×3mm	×2
M4×30mm Screw	×1
M4 Lock Nut	×1

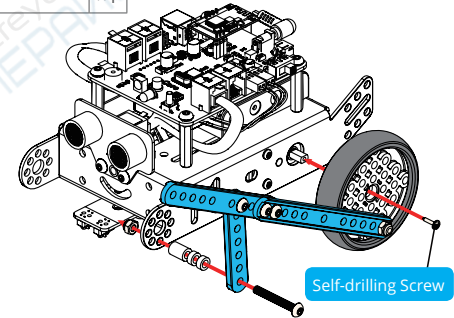

Step 4

M4×14mm Screw	×1
M4 Lock Nut	×1
Beam 0412-076-Blue	×1

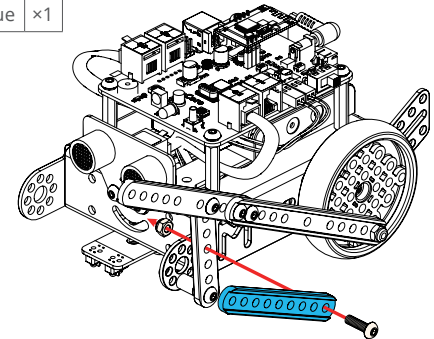

Step 5

M4×14mm Screw	×2
M4 Lock Nut	×2
Beam 0412-076-Blue	×1

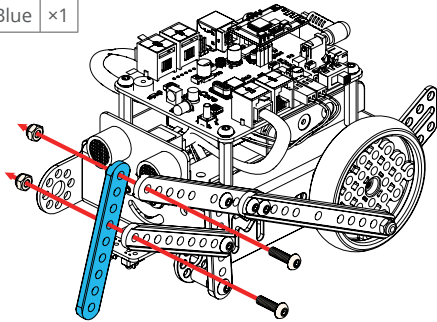

Step 6

M4×14mm Screw	×1
M4 Lock Nut	×1
Plate 45°-Blue	×1

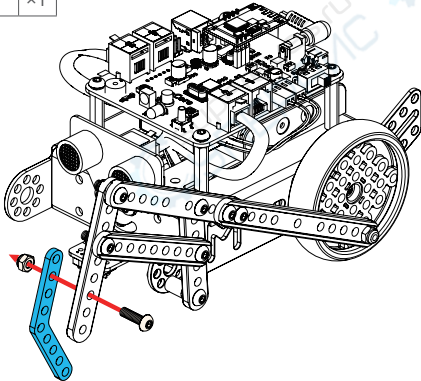

Step 7

Now let's build the right side of Mantis.

M4×22mm Screw	×1
Plastic Spacer 4×7×3mm	×2
M4 Lock Nut	×1
Beam 0412-108-Blue	×1

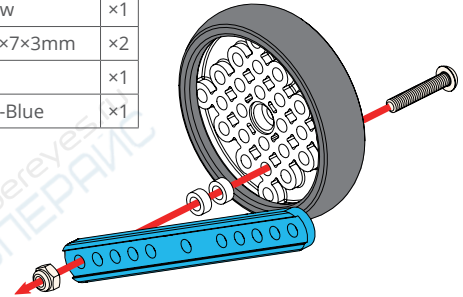

Step 8

M4×14mm Screw	×3
M4 Lock Nut	×1
M4 Nut	×2
Beam 0412-092-Blue	×1
Beam 0412-060-Blue	×1

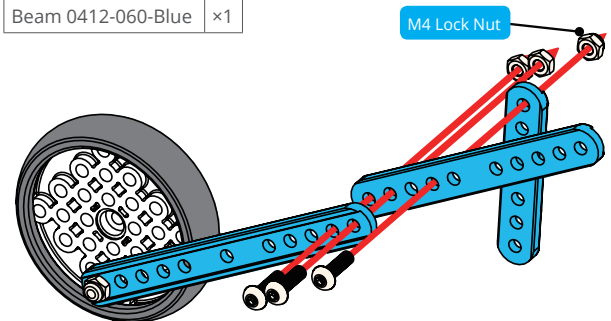

Step 9

Please fix the self-drilling screw on motor through the center of wheel.
The self-drilling screw here is the M2.2 x 9mm self-drilling screw of mBot.

Plastic Spacer 4×7×10mm	×1
Plastic Spacer 4×7×3mm	×2
M4×30mm Screw	×1
M4 Lock Nut	×1

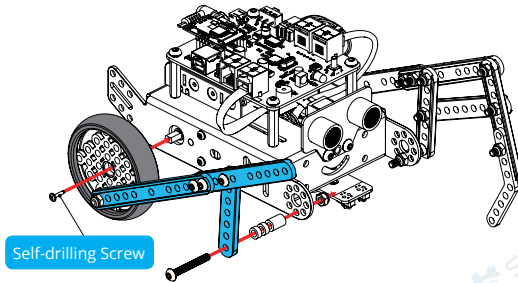

Step 10

M4×14mm Screw	×1
M4 Lock Nut	×1
Beam 0412-076-Blue	×1

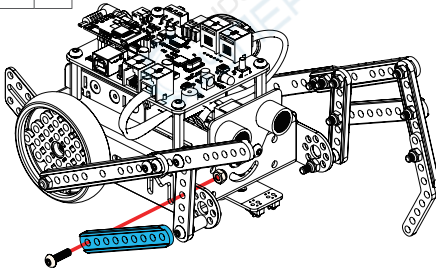

Step 11

M4×14mm Screw	×2
M4 Lock Nut	×2
Beam 0412-076-Blue	×1

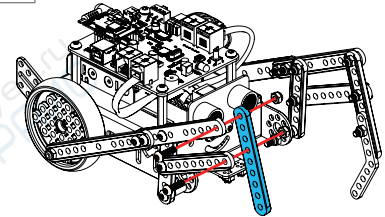

Step 12

M4×14mm Screw	×1
M4 Lock Nut	×1
Plate 45°-Blue	×1

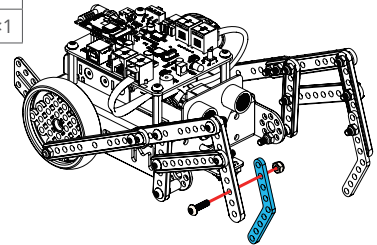

Good job !

You have finished the construction.
Now you can control your Mantis according to the constructions on page 3.

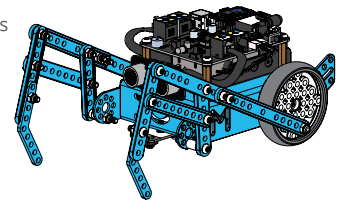

Six-legged Robot - Crazy Frog

mBot Class mBot Add-On Pack

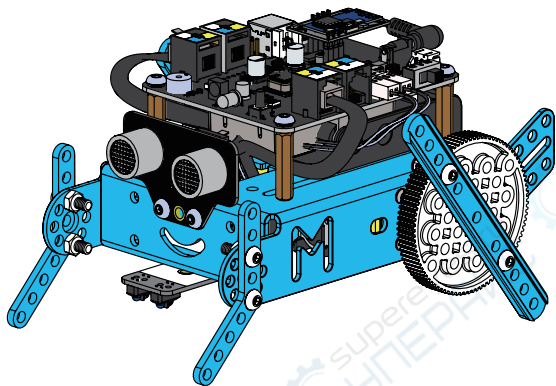

Six-legged Robot - Crazy Frog

Six-legged Robot - Crazy Frog

If your mBot already has an mCore case, please keep it for later construction.

Step 1

Please disassemble the tires for later construction.

M4×14mm Screw	×2
Beam 0412-108-Blue	×1
M4 Lock Nut	×2

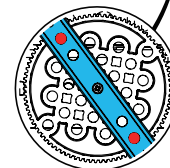
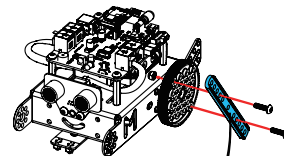

This is the front view of wheel , please insert screw through the hole marked red and fit lock nuts.

Step 2

Plate 45°-Blue	×1
M4×14mm Screw	×2
M4 Nut	×2



Tip
Rivets and plastic spacers
4x7x3 mm are equivalent of
screws and nuts for construction

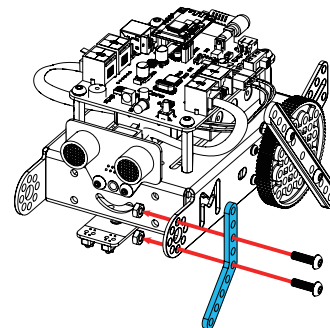

Step 3

Now let's build the right side of Crazy Frog.

M4×14mm Screw	×2
Beam 0412-108-Blue	×1
M4 Lock Nut	×2

This is the front view of wheel , please insert screw through the hole marked red and fit lock nuts.

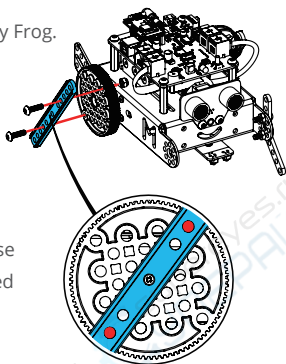

Step 4

Plate 45°-Blue	×1
M4×14mm Screw	×2
M4 Nut	×2

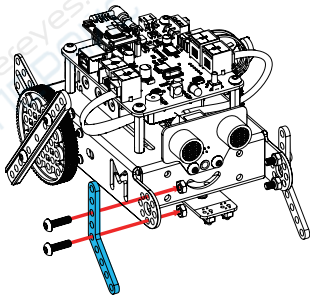

Good job !

You have finished the construction.

Now you can control your Crazy Frog according to the constructions on page 3.

