

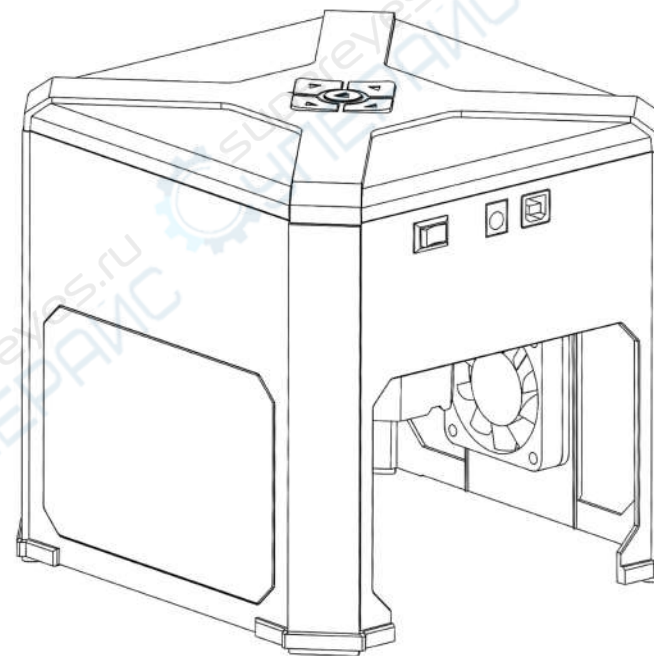

K6 User Manual



K6 Laser Engraving Machine User Manual
Please read this user manual carefully before use

Safety Instructions

Thank you for choosing our laser engraving machine, which is a high-tech optical-electric mechanical equipment. Please read the user manual carefully and follow the instructions for better use and maintenance of the equipment.

Important Statement!

All losses resulting from improper use or failure to follow the manual instructions shall be borne by the user itself. Our company owns the final interpretation right of the user manual as well as the right to modify all the items, data and technical details in this user manual.

Safety Precautions

- ★The operator must read the user manual carefully before use and strictly abide by the operation instructions.
- ★Risks may exist in laser processing and the user should carefully consider whether the object is suitable for laser processing.
- ★The object to be processed and corresponding emissions shall comply with the requirements of local laws and regulations.
- *This machine adopts four types of laser equipment (strong laser radiation), which may cause the consequences as follows:
 - ①Ignite the ambient combustibles;
 - ②Other radiation or toxic and harmful gases may be produced during the laser processing of different objects;
 - ③Direct exposure in laser radiation can cause physical injury. Fire-fighting equipment must be available on the site. It's prohibited to stack flammable and explosive materials on the workbench and around the equipment. At the same time, the site must have good ventilation.
- *The place to use the machine should be dry, free from interference and influences by pollution, vibration, strong electricity and magnetism. Ambient temperature should be 10-35°C and humidity should be 5-95% (no condensing water)
- ★Working voltage: AC100-240V.
- *The engraving machine and other related equipment must be safely grounded before it switched on for operation.
- ★The machine must be fully monitored during the whole operation process. All power must be cut off before personnel departure to prevent abnormal consequences. In case of any accidents, please cut off the power immediately!
- *It's prohibited to place any irrelevant objects with total reflection or diffuse reflection in the machine to prevent the laser from being reflected to human body or flammables.
- *Keep the machine away from electrical equipment which is sensitive to electromagnetic interference, otherwise the electromagnetic interference may occur.
- *Laser machine has high voltage or other potential dangers, it's prohibited to be disassembled by non-professionals.

Safety Instructions

Pay attention!



1. When the laser is turned on, it's prohibited to aim at humans, animals and flammables to avoid skin burns and fire.



2. The laser brightness is harmful to the eyes. Do not look directly at the laser.



3. Keep hands away from the machine during operation to avoid injury.



4. Turn off the machine when it is not in use to avoid misoperation by third parties.

Maintenance

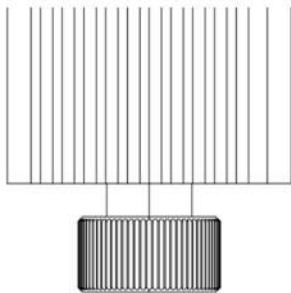

Laser head is consumable. It's recommended to keep the machine power off for 10 minutes after 4-hour engraving and keep the machine power off for 10 minutes after 1-hour cutting.

K6 Laser Engraving Machine User Manual



Contents

01 Product Structure and Accessories	01
02 Product Parameters	03
03 Function Display and Focus	04
04 Driver Download and Installation on PC	05
05 Driver Installation on PC and Online Operation	06
06 Introduction to Software Application on PC	09
07 Software Download and Online on Mobile Devices	14
08 Introduction to Software Application on Mobile Devices	15
09 FAQ	19

01 Product Structure and Accessories

01 Front View

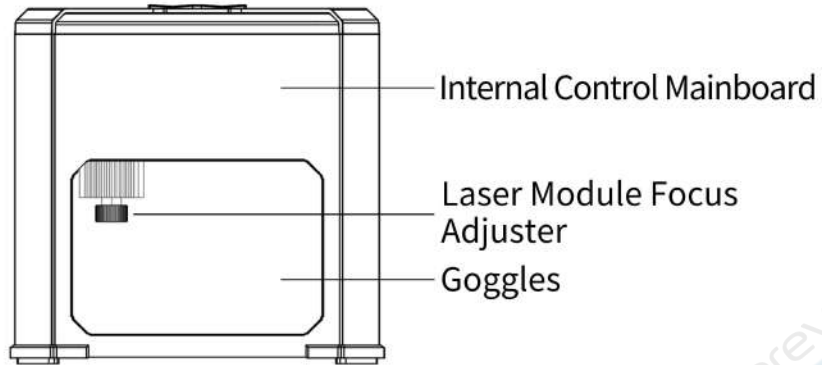

02 Side View

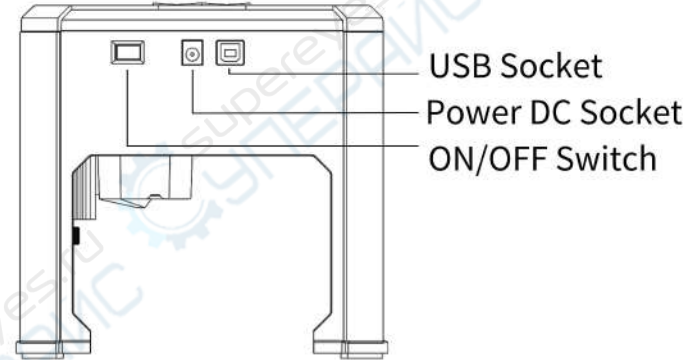

03 Rear View

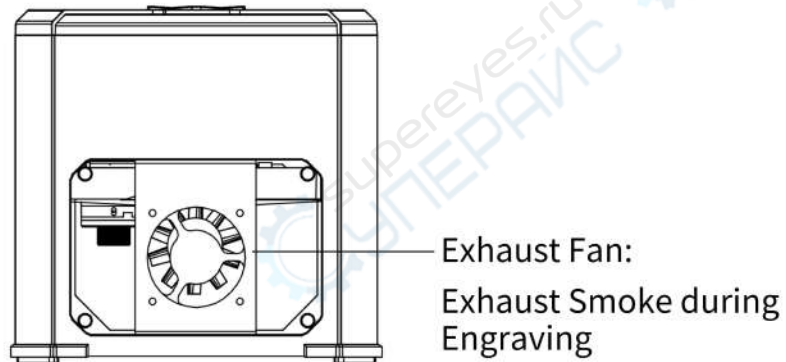

04 Bottom View

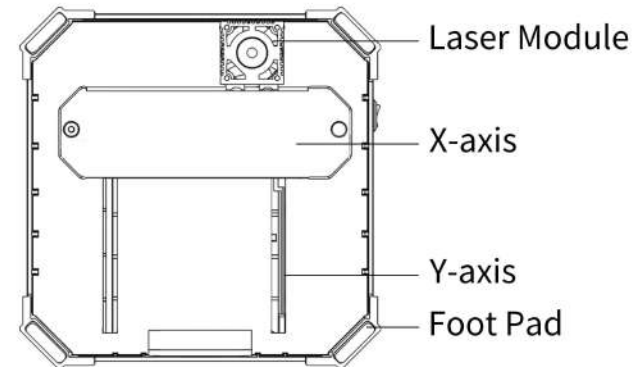

01 Product Structure and Accessories

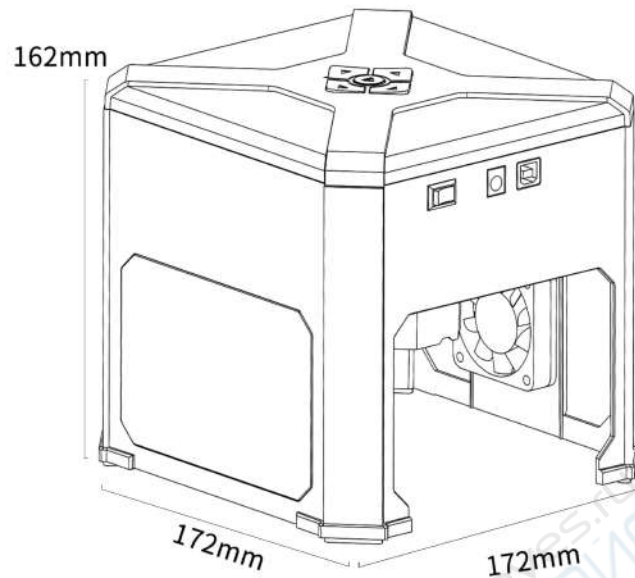

Detail of accessories

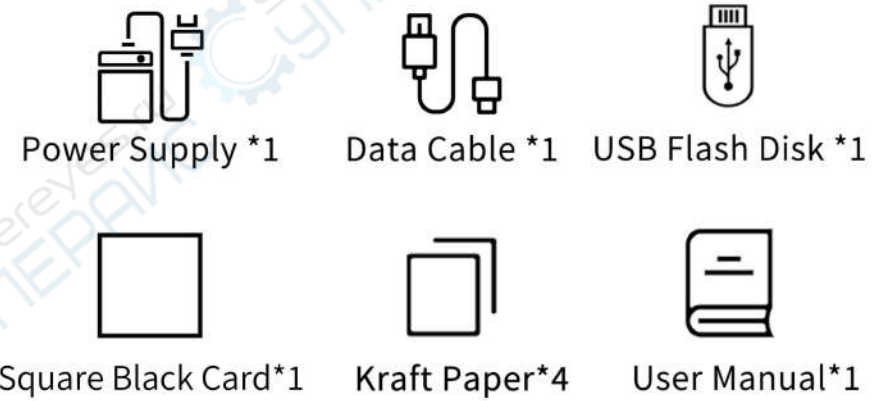

- 1. Power supply: Supply power for engraving machine
- 3. USB Flash Disk: Contain driver, software, electronic user manual
- 5. Kraft paper: Used as engraving test

- 2. Data cable: Connect the computer and the machine
- 4. Square black card: Placed on the object to be engrave so as to watch the point of focus
- 6. User manual: Introduction to engraving machine and operations

02 Product Parameters

Model	K6
Material	ABS
Laser Focus	Knob-Type Focus Laser Module
Focus Range	30 - 50 mm
Best Focal Length	100 mm, Light Spot 0,05 mm
Power Supply	DC 005, DC 12V/2A
Data Interface	USB, Bluetooth, WI-FI
Cooling Type	Air Cooling
Power	17W
Laser Optical Power	3W
Laser Wavelength	450nm
Laser Service Time	>10000H
Spot Shape	Point
Laser Control	High-Speed PWM
Engraving Area	80*80mm
Engraving Accuracy	0.05mm
Engraving Speed	10-60mm/s
Suitable Materials	Paper, wood chips, plastic, leather, cloth, etc.
Compatible System	Windows 7/Windows 10/MAC/IOS/Android
Photo Format	JPG/JPEG/BMP/TIF/GIF/DXF
Product Size	172*172*162 mm
Package Size	215*215*225mm
Product Weight	0.96kg
Package Weight	1.65kg

03 Function Display and Focus

Instructions to Laser hHad Focus Adjustment:

Horizontally put in the object to be engraved, place the kraft paper provided to cover the object, then watch the blue panel on the front of the machine to make the adjustment;

1. Adjust the focus of laser head to the minimum size. Improper focus adjustment may cause failed engraving or bad engraving effect.

2. Best focal length:
50-100mm

3. Focus adjustment is very important

- ① Rotate the laser head left and right to adjust the light spot to the minimum size;
- ② It's recommended to keep the laser head about 50-100mm away from the object to be engraved.
- ③ Pay attention to readjust the laser focus to engrave the objects of different heights.

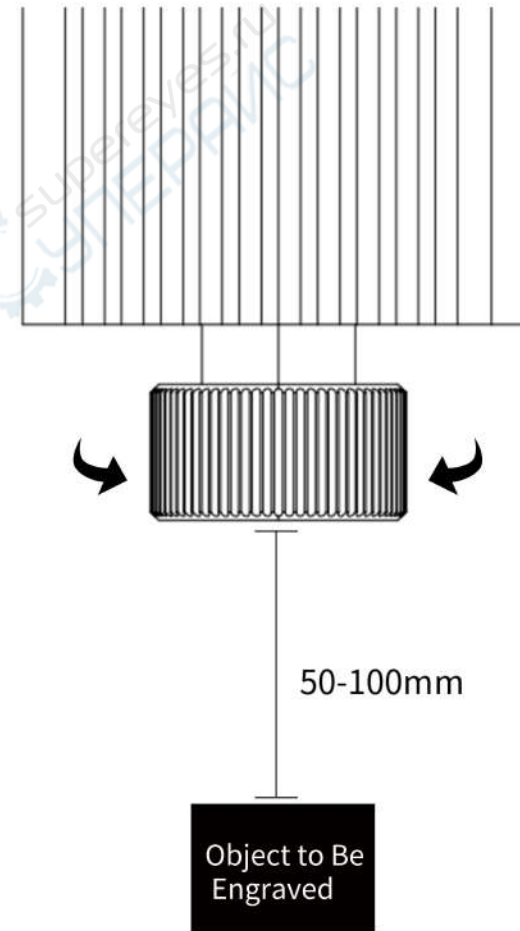
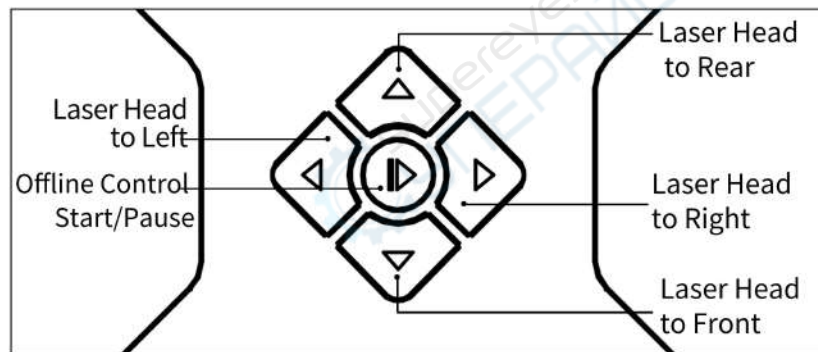

04 Driver Download and Installation on PC

Software can be acquired as follows:

Method 1: Acquire the driver, software, photos and other data from the USB flash disc provided (Note: Before the use for the first time, please copy all the data from the USB flash disc to your computer as backup to prevent accidental loss due to improper operation.)

Method 2: Download at the designated website

Windows/MAC Download URL:

www.dkjxz.com/download/K6_Software.zip

Engraving Machine Download URL:

www.dkjxz.com

URL to Obtain Information:

User Manual Download URL:

www.dkjxz.com/download/K6_User Manual.zip

Video URL:

www.dkjxz.com/download/K6_video.zip

1.Path to Install Driver:

Enter the USB flash disc and double click the folder:
/01-windows/driver/Windows10_Driver/CP210xVCPInstaller_x64/click Install/Next/Confirm to complete the installation.

Windows Driver Installation



6 Click "Next"



7 Click "Confirm" to complete the installation

05 Driver Installation on PC and Online Operation

2.Path to Install Software:

Enter the USB flash disk and double click the folder:/windows/software/Laser_2.0.4(211018) / After the progress bar has done,the installation is completed /Laser.

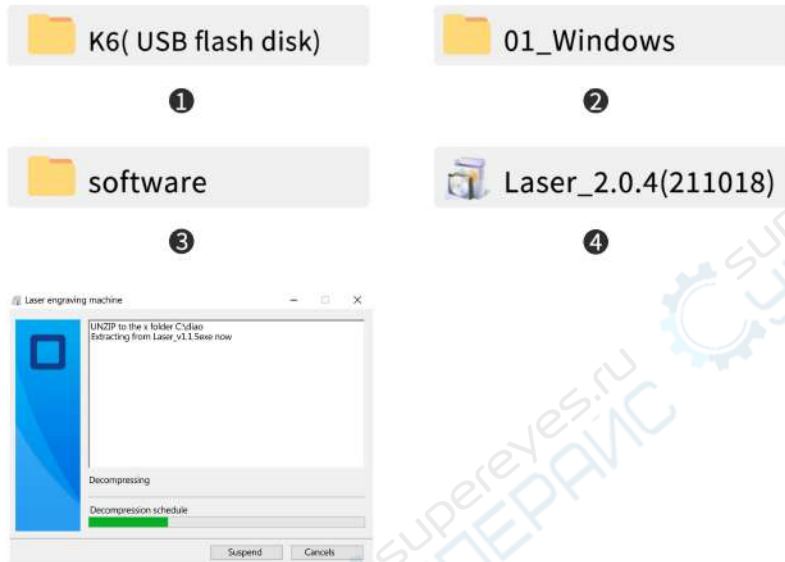

5 After the progress bar has done, Laser installation is completed.

Tips:

After clicking Laser_2.0.4 (211018), if anti-virus software or PC Manager prompts to warn the risks. Laser_2.0.4 (211018) file is a win system installation package. If it is misjudged as a suspicious file,Please select “allow all operations” to complete the software installation.

3.Online Operation:

Connect the machine to the computer with data cable Double click the software icon — click the “connect device” icon — the icon turns blue to complete the online connection

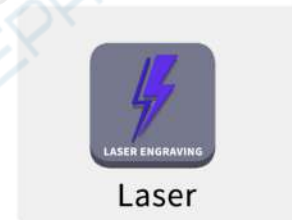

1 Double click the software icon



2 Click the “connect device” icon



3 The icon turns blue to complete the online connection



05 Driver Installation on PC and Online Operation

Mac Driver Installation



4 Click to continue



6 Click to continue the installation

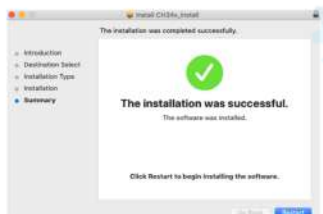

8 Complete the installation

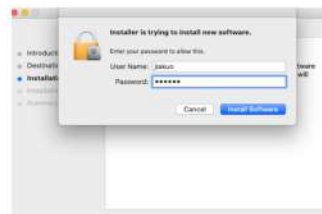
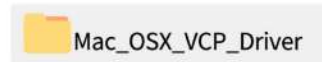

5 Enter the computer password

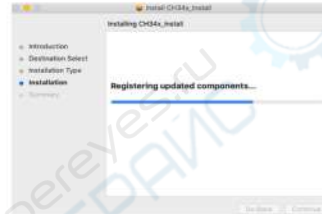

7 Continue the installation

1.Path to Install Driver:

Path to Install Driver: Enter the USB flash disk and double click the folder: 02_MAC/driver/Mac_OSX_VCP_Driver/Installation introduction/installation type/installation/installation completed

Note: The software can be installed after the driver has been installed, please watch the video for detailed operation.

 Video of MAC driver and software installation

05 Driver Installation on PC and Online Operation

Mac software installation and online Introduction



1



2



3



4 Double click the software icon

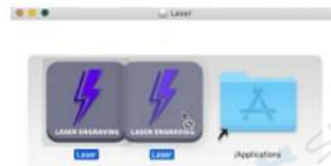

5 Left click the icon and drag into the Applications folder in the right



6 Complete installation

2. Path to Install Software:

Enter USB flash disk and double click the folder: 02_MAC /software/Laser-2.0.4/move software icon to the right/ complete installation

3. Online operation:

Connect the machine to the computer through data cable Double click the software icon — click “connect device” icon — the icon turns blue to complete the online connection



1 Double click the software icon

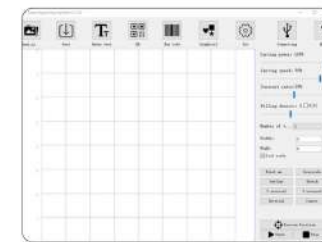

2 Click “connect device” icon

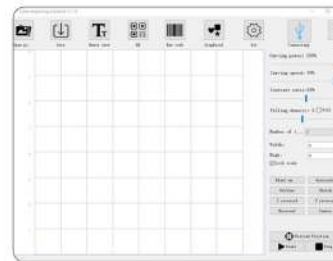



3 The icon turns blue to complete the online connection

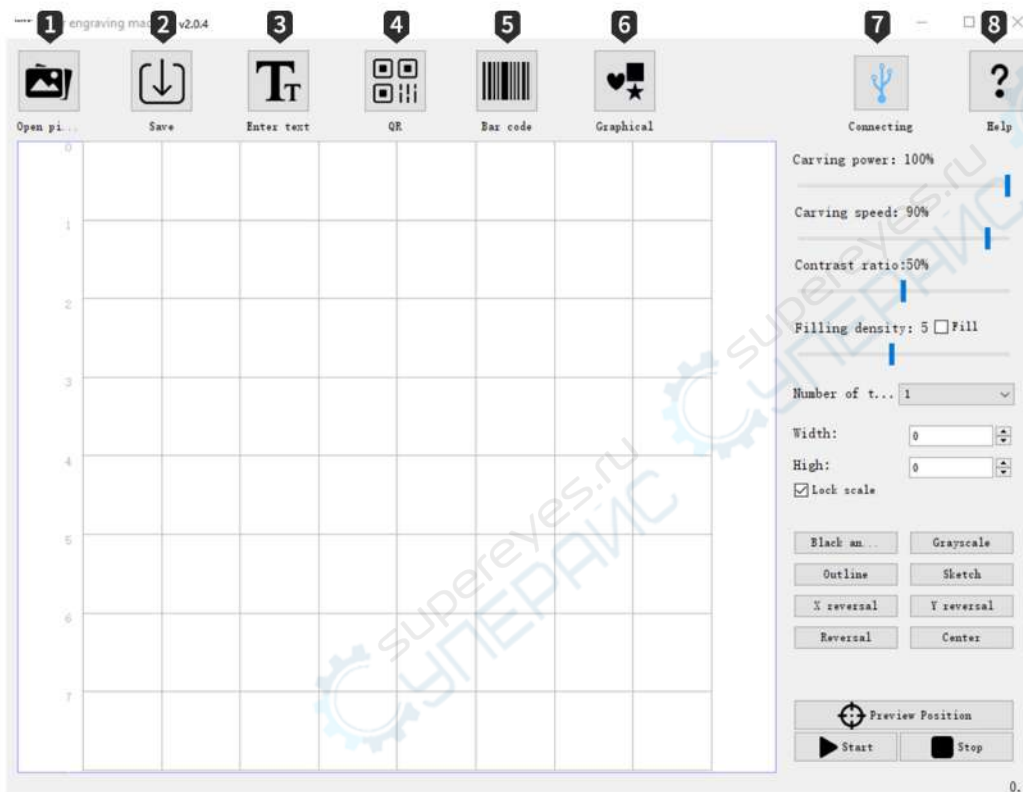

06 Introduction to Software Application on PC

Introduction to Icon Functions in Software Interface:



- 1 Open**
Load photos from computer
- 2 Save**
Save the edited texts and photos
- 3 Input Text**
Import text, font, size, horizontal, vertical, vectorization Editing function
- 4 QR code**
Create QR code
- 5 Bar Code**
Create Bar code
- 6 Graphics**
Round-square-heart-pentagon, quick creation
- 7 Connect to device**
The icon turns blue after the connection is done 
- 8 Help**
Open the link; watch the demo video and refer to the FAQ

06 Introduction to Software Application on PC

Setting of Software Parameters:

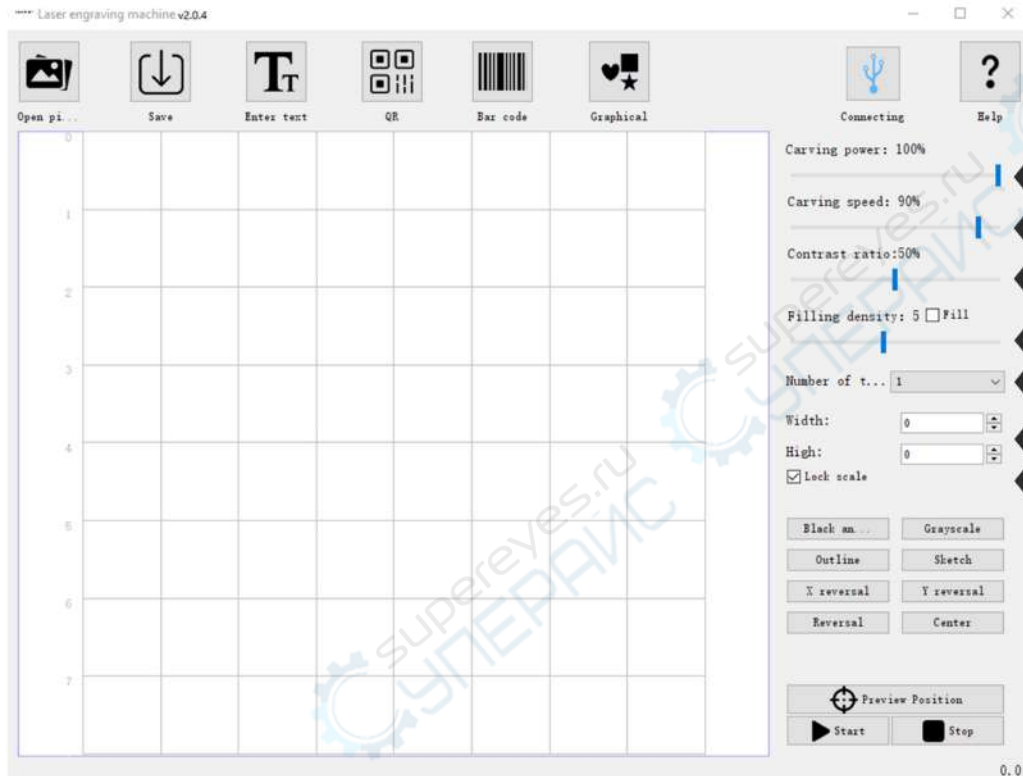

1 Engraving Power

Adjust the power level to engrave different materials

2 Engraving Speed

Set the engraving speed, the engraving speed of determines the engraving depth

3 Contrast

Drag the slider to adjust the contrast of text and photo



4 Filling Density; Filling

The filling effect can only be effective for vector graphics, select vectorization, Click Fill on the text photo, drag the fill slider to adjust the filling density

5 Engraving Times

Set the number of engraving times

6 Width; Height

Adjust the width and height of text photo separately at will

7 Proportional Zoom

Lock photo text to proportionally zoom in/out

06 Introduction to Software Application on PC

Setting of Software Parameters:

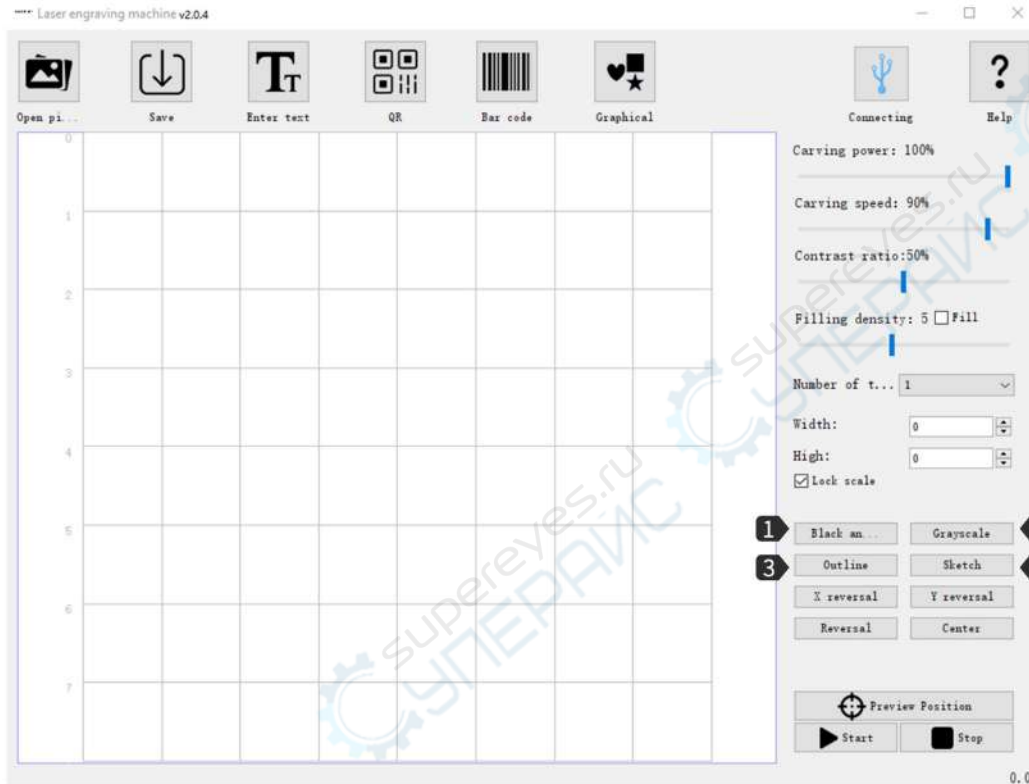

1 Black and White

To process photos to black and white

2 Grayscale

Grayscale mode, adopt the function for engraving photos to adjust photo grayscale

3 Contour

Cutting mode for wireframe cutting of engraving machine

4 Sketch

Sketch mode, enhance the 3D effect of photo outline



Black and White



Grayscale



Contour



Sketch

06 Introduction to Software Application on PC

Setting of Software Parameters:

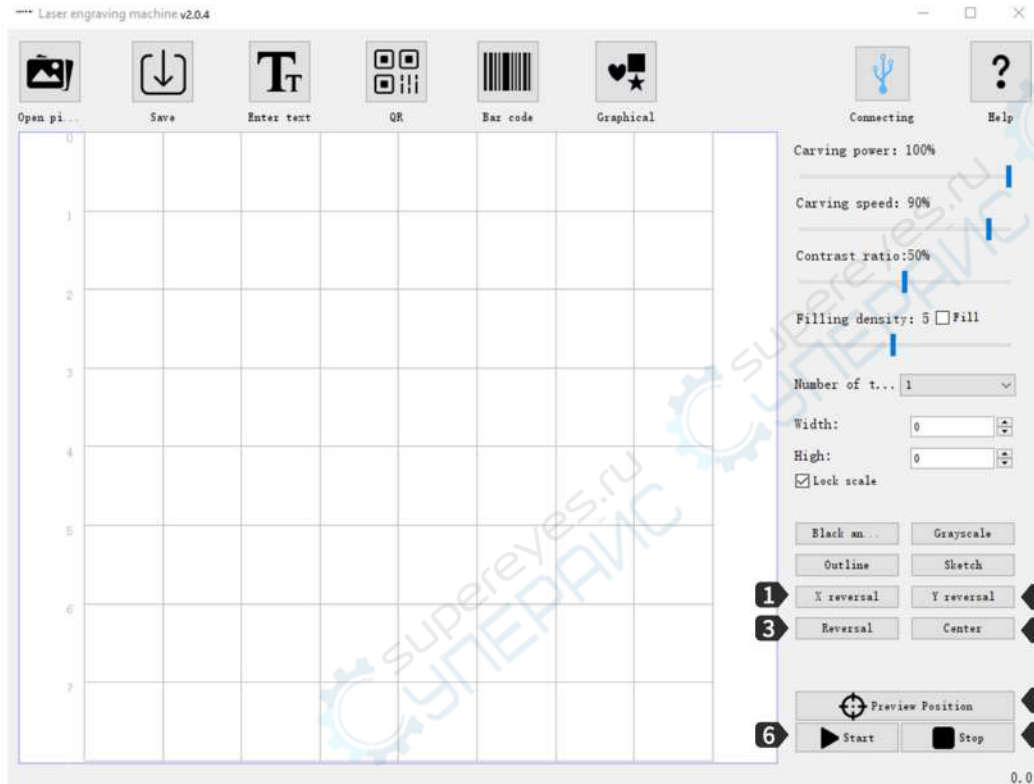

- 1 **X Mirror**
Horizontal Rotation Effect
- 2 **Y Mirror**
Vertical Rotation Effect
- 3 **Reverse Color**
Reverse background color of text and photo
- 4 **Center**
One click to center the text and photo in preview area
- 5 **Preview Location**
Preview to confirm engraving position
- 6 **Start**
Start engraving
- 7 **Stop**
Stop engraving

06 Introduction to Software Application on PC

Introduction to Interface Loading Content:

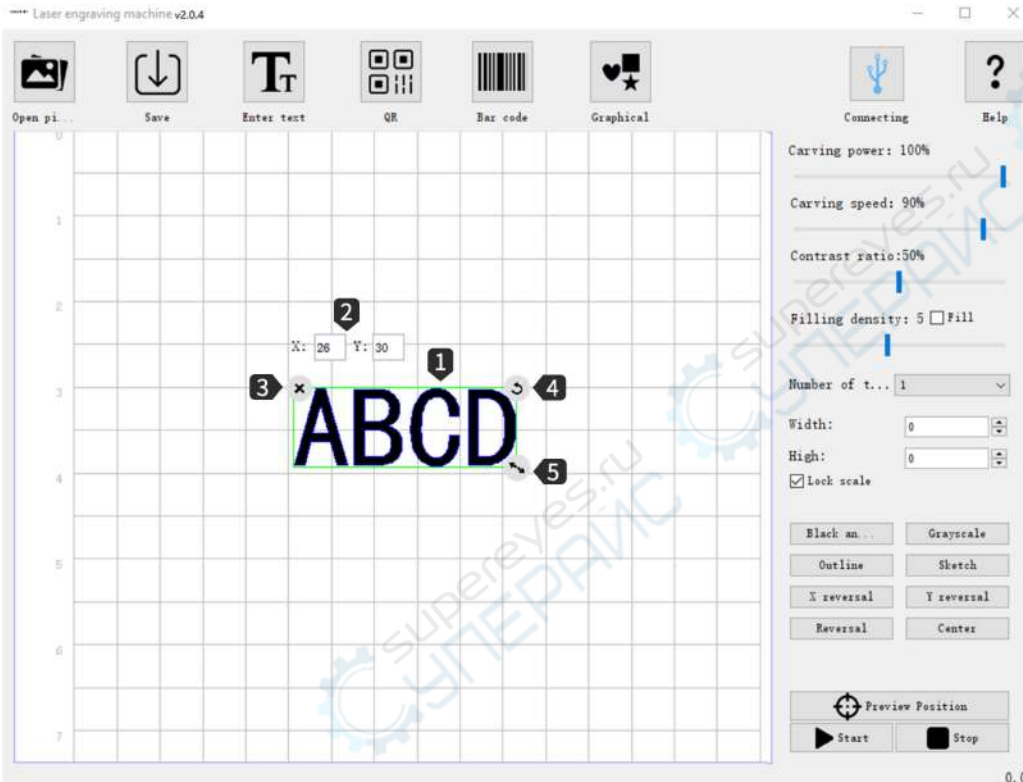

- 1 After loading the text and photo, left click the mouse to move the position of the text and photo, right click the mouse to move the drawing board horizontally, roll mouse wheel to zoom in/out the drawing board.
- 2 X:26 Y:30 only indicate the position coordinates where the text and photo stay; when move the text and photo, the coordinates will change based on different positions.
- 3 ✕ Clear the text and photo on the drawing board
- 4 ↻ Left click the mouse to rotate the text and photo 360°
- 5 🖱️ Left click the mouse and drag to zoom in/out the text and photo

07 Software Download and Online on Mobile Devices

1. Software Download and Installation:

Method 1: APP download URL:
www.dkjxz.com/download/K6_APP.zip

Method 2: Scan the QR code to download.



URL to Obtain Information:

User Manual Download URL:
www.dkjxz.com/download/K6_User Manual.zip

Video URL:
www.dkjxz.com/download/K6_video.zip

Note: 1. For Android system, open the browser to scan the QR code to download;
2. Corresponding authority should be permitted after successful installation;

2. Connect APP with Machine

- 1 Connect the machine to power supply;
- 2 Activate Bluetooth function in the mobile phone;
- 3 Open engraving software in the phone, click "No Connection" in the upper right corner to automatically search for the device;
- 4 Then click "Engraver-000###";
Note: "000###" represents the serial number of the machine.
- 5 Wait for 1~2 seconds till "Connected" displayed in the upper right corner, which indicates that the APP has successfully connected to the machine, then continue with the next step.

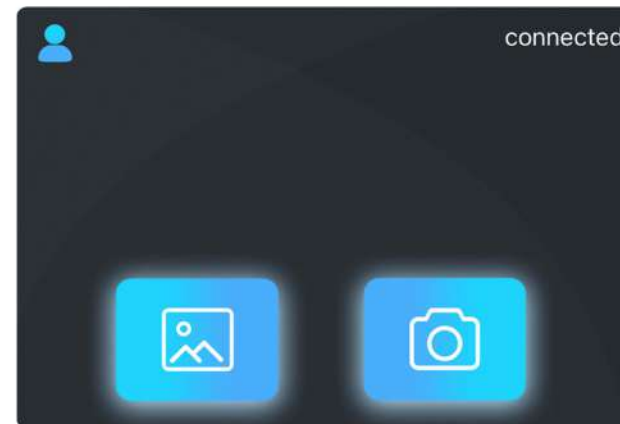

08 Introduction to Software Application on Mobile Devices

Introduction to software interface (loading) :

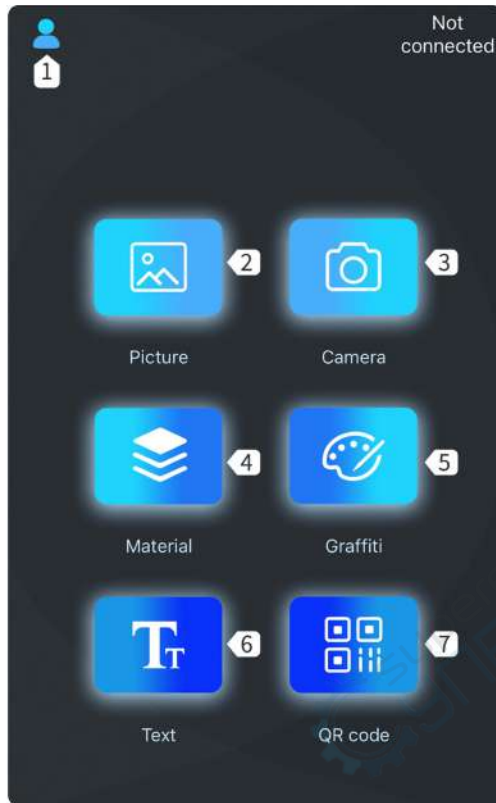

- 1 Setting**
New User Guide/ Feed-back / User Agreement and PrivacyClauses/Equipment/Language Setting
- 2 Load Photos for Engraving**
Add photos from Album
Add photos from Gallery
- 3 Take photos via camera**
- 4 Software Built-in Graphics**
- 5 Add Graffiti**
Self-draw Text
Photo
- 6 Edit Text**
- 7 Add QR code**
QR Code,Barcode



- 1 Cutting**
Customized Cutting, Round Cutting, Square Cutting
- 2 Photo or Text**
(Content can be superimposed)
Input Text
Load Photos from Album
Shoot via Camera
Add Photo from Material Library
- 3 Eraser**
Modify the photo with erase

08 Introduction to Software Application on Mobile Devices

Introduction to software interface (Loading content) :

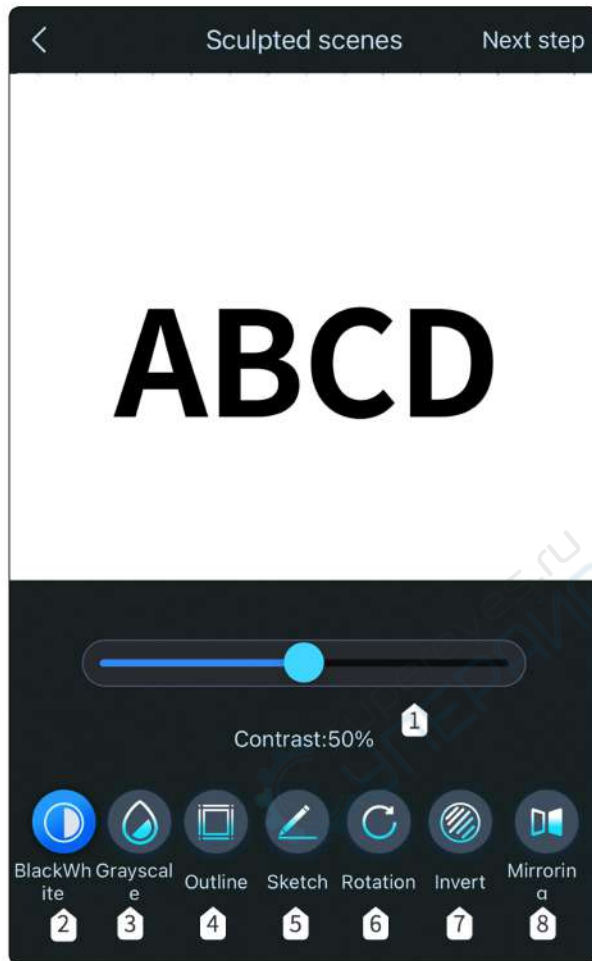

- 1 Contrast**
Drag the slider to adjust the contrast of text and photo
ABCD ABCD ABCD
Contrast 16 Contrast 50 Contrast 80
- 2 Black and White**
To process photos to black and white
- 3 Grayscale**
Grayscale mode, adopt the function for engraving photos to adjust photo grayscale
- 4 Contour**
Cutting mode for wireframe cutting of engraving machine
- 5 Sketch**
Sketch mode, enhance the 3D effect of photo outline

Black and White Grayscale Contour Sketch
- 6 Whirling**
Can rotate 90 degrees, 180 degrees or 360 degrees
- 7 Reverse Color**
Reverse background color of text and photo
- 8 Mirroring**
Horizontal Rotation Effect, Vertical Rotation Effect

08 Introduction to Software Application on Mobile Devices

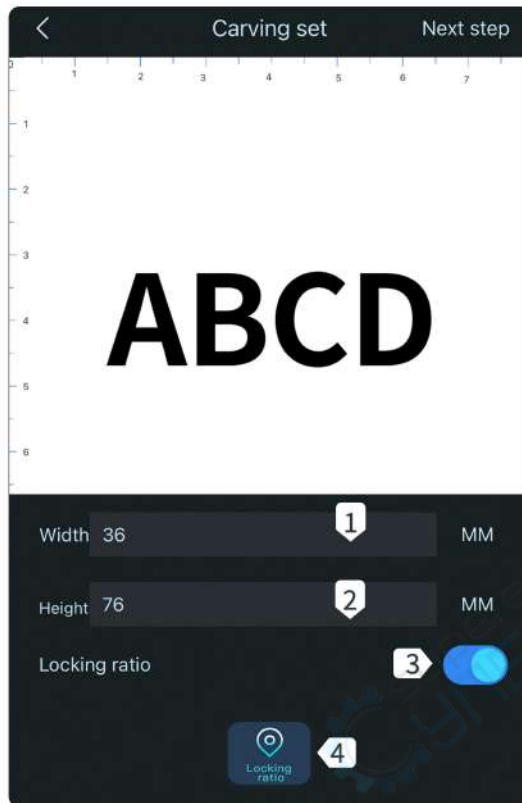
Introduction to Software Interface (Load Content):



- 1 Width
Set engraving width
- 2 Height
Set engraving height
- 3 Lock Ratio
Scale engraving size proportionally
- 4 Region Positioning
Preview Engraving Position Determine Engraving Position



- 1 Material Selection
App built-in materials, which can be directly selected based on the materials to be engraved
- 2 Add Materials
Add and set materials, material name/laser power/engraving speed
- 3 Laser Power
Adjust power level to engrave different materials
- 4 Engraving Speed
Engraving speed setting, engraving speed determines the engraving depth
- 5 Repetition Times
It represents the number of engraving times

08 Introduction to Software Application on Mobile Devices

Introduction to Software Interface (Load Content):

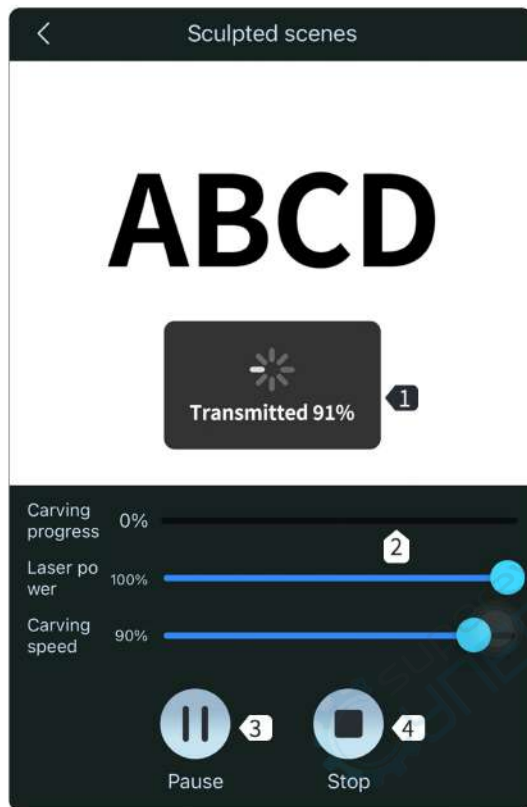

- 1 Uploading content**
When the transfer progress has been 100% completed, the engraving can be started.
- 2 Carves Progress**
Show me the progress of the sculpture
- 3 Suspend**
Suspend engraving
- 3 Stop**
Stop engraving

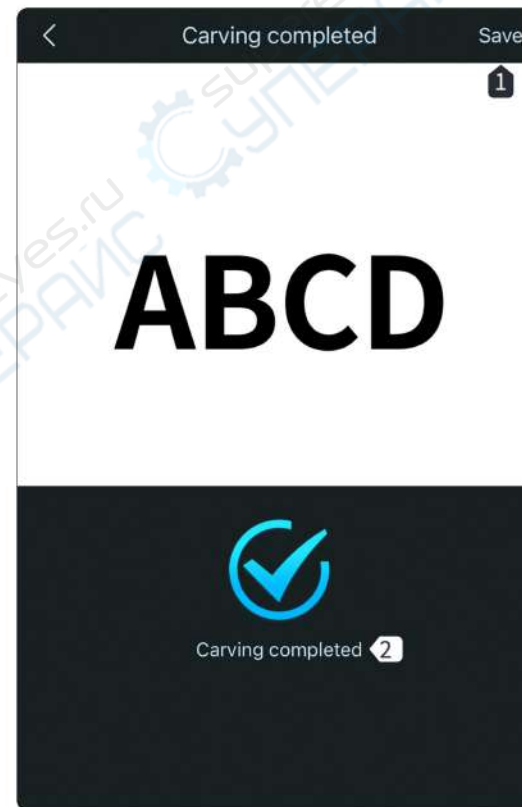

- 1 Save**
Save the current engraving content and view in the phone album
- 2 Engraving Completed**
Current content has been engraved

09 FAQ

K6 FAQ

一、 No response from the machine when being powered on.

1. No power supply: Please check the socket and switch as well as the machine power socket to ensure that they have been correctly plugged with normal power supply.

二、 It cannot be connected to computer

1. USB cable not connected: Please check the USB data cable interface on the machine and computer to ensure it's correctly plugged. The USB interface on the front panel of some desktop computers is invalid, it's better to connect to the interface on the back.
2. Driver not properly installed: Install the driver according to the instructions. After the installation is done, the computer will recognize the device as a serial port, which means the hardware connection is OK.
3. Other special problems: Pull out the USB data cable and power cable, keep the machine power off for 5 seconds and then try the connection once again.

三、 No response from the phone APP when being connected to the machine.

1. Wrong Bluetooth connection: Make sure it's connected to the Bluetooth released by the machine. Please read "App Connection" in the User Manual for details.
2. Incompatibility: In the case of abnormal connection due to incompatibility of newly-released phone or upgraded system, please contact our customer service with the screenshot of phone configuration so as to get technical support as soon as possible.

四、 Shallow engraving effect or no traces.

1. Inaccurate focus: Refer to the "Focus Adjustment" in the User Manual to make the correct focus.
2. Engraving speed: Too fast speed is due to short burning time. Please read the "Engraving Parameters" in the User Manual to readjust the parameters.

09 FAQ

3. Photo color is too light: The photo added should be clear. If the line is too thin or the color is too light, the engraving effect will be directly influenced.
4. Position of object to be engraved: If the object is placed obliquely, the focal length of laser is fixed, so the object should be placed horizontally in parallel to the machine; otherwise, the inaccurate focal length will result in bad engraving effect.

五、Offline engraving unexpectedly stops

1. The photo is not completely downloaded when being connected to computer, please download the photo once again.

六、Inaccurate focus

1. Read the “Focus” in the User Manual. Please use the yellow focus plate provided with the camera to make the focus. If the focus plate is missing, a thin and rough yellow or white cardboard can be used as the substitution to make the focus once again. Please contact the online customer service for relevant information.

