

# **Operation Manual**

**For**

**NDJ-1 Rotary Viscometer**

Thank you for using NDJ-1 Rotary Viscometer. NDJ-1 is easy to use, in order to install and operate accurately, and make full use of product features, we suggest you to read the manual before using.

- The company possesses the final interpretation power.
- The company reserves the power of amending technical rules without prior notice.
- The company reserves the power to amend the manual without further notice.
- May not be translated into other languages, reproduction prohibited without written permission.

# Cataloge

1、 General	.....
2、 Main technical data	.....
3、 Principle	.....
4、 Installation	.....
5、 Operation procedures	.....
6、 Precaution	.....
<b>Packing List</b>	.....

## 1. General

NDJ-1 rotary viscometer is a new instrument used for determining the liquid viscose capacity and the absolute viscosity. NDJ-1 has been widely used to determine and measure the liquid viscosity in many applications such as grease, painting, plastic, pharmacy and adhesives. It is a precision instrument to monitor and control the stable quality of products in the manufacturing.

## 2. Main technical data

- 1) Measurement range: 10-100.000 mPa·s
- 2) Rotor specification: 0, 1, 2, 3, 4, 5, five kind rotor (0# rotor could measure the viscometer from low viscometer to 0.1 mPa·s)
- 3) Measurement error:  $\pm 5\%$  (Newton liquid)
- 4) Power supply: Voltage-- $220\pm 22\text{V}$ , Frequency— $50\text{ Hz}\pm 0.5\text{Hz}$
- 5) Dimensions: 300 mm  $\times$  300 mm  $\times$  450 mm
- 6) Net weight: 1.5 Kg (the base not included)

## 3. Principle

1) (Figure 1) Synchronous motor rotates with stable rate, connect scale disk, through hairspring and rotating shaft, drives rotors to rotate. The rotors will subject to a torque moment proportional to liquid viscosity because of the liquid viscose hysteresis. The torque moment will be measured by the sensors and processed into the viscosity and shown on the display.

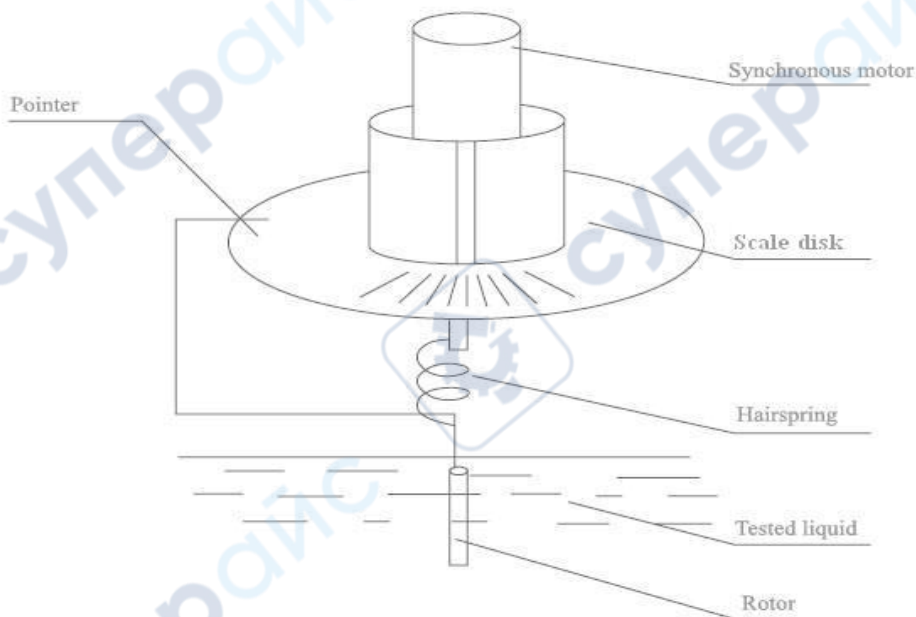

Figure 1

- 2) Rate can be changed by using gear system and clutch, operated by rotary knob, four optional velocity.
- 3) According to different equipments, different rotors (Five rotors: NO.0-NO.4) will be attached, it can be select with the velocity according to the viscosity of the liquid.
- 4) The fixed control gear of pointer are used for accurate reading. When the rate is so fast (30 rpm, 60 rpm) that you can not get the reading while it rotated, press pointer joystick, fix the pointer in order to get the reading.
- 5) The rotor bracket is used for the protection of rotors and the stability of the measurement, a more reliable measuring result can be made by using the protection bracket.
- 6) It can be used as a portable instrument, assigned fixed bracket and elevating system. Generally, it should be fixed when determine small amount or the temperature is fixed in the laboratory.
- 7) The instrument has gears and damping elevate mechanism. It is stable for instrument lifting.
- 8) The whole set of instrument has good quakeproof packing to ensure the precision of instrument.



Figure 2

### Installation

1. Take out the bracket, package, stanchion and so on from the packaging.
2. Screw the column to the threaded hole behind the bracket, and put the tooth profile surface in the column facing front the bracket. Screw the hex nut tight by wrench to prevent the column running.
3. Rotational move the lifting chuck knob to check the flexibility and self-looking of lifting chuck. Found the lifting chuck too loosen and too tight phenomenon, can be used hex nut wrench to adjust the tight screw. So that it can lift from top to bottom. And it is suitable for tight to prevent the situation of automatically falling after installing the viscometer.

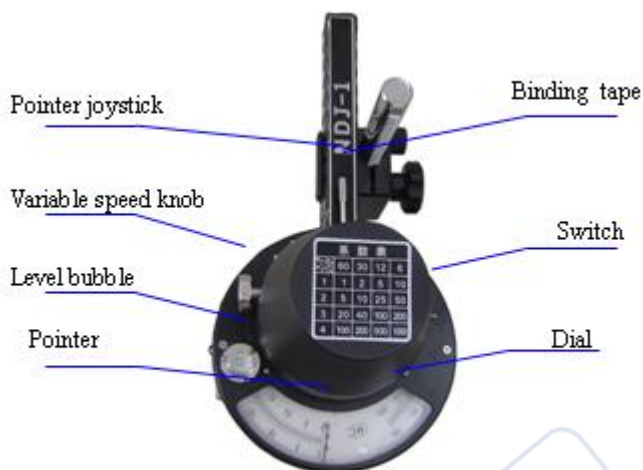

(figure 3)

4. Take out viscometer from package and mount it on the lifting collet, tight it by handle setscrew to avoid loosen(as level as possible), link the power supply, take away the rubber band on the pointer joystick, screw the nut of protecting-cap loosen under the instrument, take away the protecting -cap.

5. Adjust the adjustment screw and put the rotor into the liquid to be measured till the level mark on the rotor reach the liquid surface.

#### Operation procedures

1. Prepare the liquid to be measured and put it into a glass beaker or a right angle container with the diameter not smaller than 70 mm, height not smaller than 130mm, take care of the liquid temperature.

2. Mount the protection bracket on instrument, turning right for mounting, turning left for removing.

3. Screw the selected rotor into connecting rod, turning right for mounting, turning left for removing , Adjust the lifting screw and put the rotor into the liquid to be measured till the level mark on the rotor reach the liquid surface. Connect power supply, turn on the equipment, screw the speed knob, select velocity, relax pointer joystick, reading data can be displayed (about 20~30 seconds) when the pointer becomes stable. Press the pointer joystick after pointer becoming stable, cut power supply, then get the reading data. If the pointer isn't in reading window after motor stop, you can press pointer joystick unceasingly, open or close the motor time after time, after practice, you can operate it familiarly.

4. When the reading data is too high or too low, the rotor or the rate can be changed, make sure the reading is between 20 and 80.

5. 0# Rotor and the testing annex of low viscosity liquid can be used following these steps below. (Figure 4)

5.1 Screw the 0# rotor into connecting bolt rod (turning left for mounting)

5.2 Put fixed sleeve into the cylinder at the bottom of the instrument, and tight setscrew of sleeve.

5.3 Assigning outer test tube with bottom, 20~25m l tested liquid should be injected into outer test tube, then follow the steps below. Assigning test tube without bottom, follow the steps below directly.

5.4 Set outer test tube into fixed sleeve and screw the test tube fixed screw tight. When screwing tight, the cone apex of test tube fixed screw should be screwed into the triangle groove at the top of outer test tube.

5.5 Immerse outer test tube and rotor into liquid, make the red dot on the fixed sleeve as level line

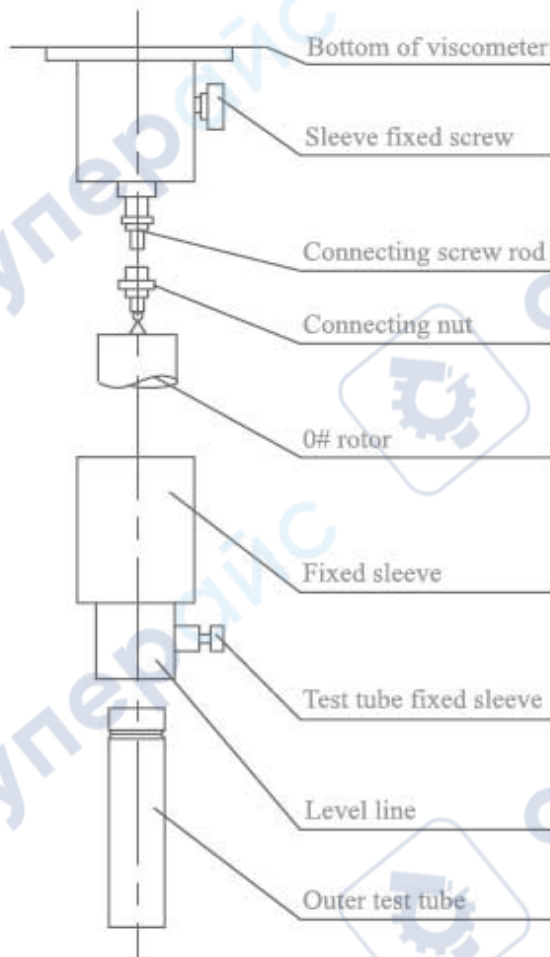

Figure 4

5. Choice of range, coefficient, rotor and rate:

5.1 Estimate approximately the viscose range, then select the rotor and the velocity

based on the range table given below:

For example, the viscosity of liquid is about 3000 mPa·s the settings should be as following:

rotor 2 # with velocity of 6 rpm,

rotor 3 # with velocity of 30 rpm

5.2 If the viscosity of liquid can not be estimated, it should take a high value for real measurement, the rotor selection should be made from smaller to larger with their number from higher to lower. In general, high viscosity should use smaller rotor with slower velocity, lower viscosity use larger rotor with faster velocity.

5.3 Coefficient: the reading must be multiplied the specific coefficient in the coefficient table in order to get the absolute viscosity.

That is:  $\eta = k \cdot \alpha$

$\eta$  = absolute viscosity

$k$  = coefficient

$\alpha$  = reading ( deflection angle)

5.4 Amendment of frequency error: when the power frequency is inaccurate, you can amend it according to the formula below:

Actual viscosity = instruction viscosity \* nominal frequency / actual frequency

5.5

	Velocity	60	30	12	6
Range					
Rotor					
1		100	200	500	1000
2		500	1000	2500	5000
3		2000	4000	10000	20000
4		10000	20000	50000	100000

### 5.6 Coefficient table:

Rpm \ Rotor	60	30	12	6
1	1	2	5	10
2	5	10	25	50
3	20	40	100	200
4	100	200	500	1000

### Precaution

1. This instrument is limited to the room temperatures
2. This instrument should be used under the designed voltage and frequency and their allowable error ranges, or incorrect results could be resulted.
3. Using the bracket fix the instrument in order to determine accurately. Handheld operation: keep the instrument stable and level.
4. Care should be taken for mounting or removing rotors, slightly and lift the connecting screw bolt to avoid a transverse force acting on rotor to cause it bending.
5. The instrument mounted with rotor should not be revolved.
6. Don't run the motor when the pointer joystick is not pressed.
7. Keep cleaned on screws and connecting points between rotor and connecting bolt rod, or a unstable rotation could be caused in the real measurement.
8. Use hand to hold the instrument when lifting up or moving down to avoid dropping it.
9. After completing measurement each time, the rotor should be fully cleaned (rotor should be removed from instrument for cleaning), then place it on the protection bracket.
10. Unauthorized removing or replacing the instrument part, and applying lubricates are not allowable.
11. When moving or shipping instrument, put on the yellow caver cap and lift the connecting bolt rod and screw the bolt on the cap tightly.
12. Suspension, emulsion or polymer and other high viscosity liquids are non-Newton liquids, their viscosity will change with shear velocity and time, it is normal for their measured inconsistent results under the selected rotor and velocity and time, and it is

not resulted from the instrument problems (in general, the rotor and velocity and time should be specified for non-Newton liquids).

13. The cautions should be taken for followings to obtain a good measuring result:

- (1) Accurately control the temperature of liquid to be measured;
- (2) Make temperature of rotor and protection bracket same as liquid;
- (3) Ensure the liquid homogeneity and without bubbles;
- (4) Put the rotor located on the center of the liquid container in real measurement;
- (5) Remove bubbles adhered on the rotor when put it into liquid;
- (6) When change the rotor or rate, keep  $\alpha$  between 30~90 as possible.
- (7) Use rotor protection bracket for measurement;
- (8) Ensure rotor and connecting screw rod cleaned;
- (9) Amend according to the amending formula when power frequency is not exact.
- (10) When pointer is stable, reading with the same angle of view.
- (11) Adjust level bubble exactly, move the instrument slowly, keep the instrument stable.
- (12) Strictly follow the operation instruction for measurement.

## Packing List

- |                                    |              |
|------------------------------------|--------------|
| 1) NDJ-1 Digital Rotary Viscometer | 1 Qt.        |
| 2) Rotors, 1#, 2#, 3# and 4#       | 1 Qt of each |
| 3) Protection bracket              | 1 Qt.        |
| 4) Bracket                         | 1 Qt.        |
| 5) Adjusting screw                 | 3 Qt.        |
| 6) Operation manual                | 1 Qt.        |
| 7) License                         | 1 Qt.        |
| 8) Warranty card                   | 1 Qt.        |