

1

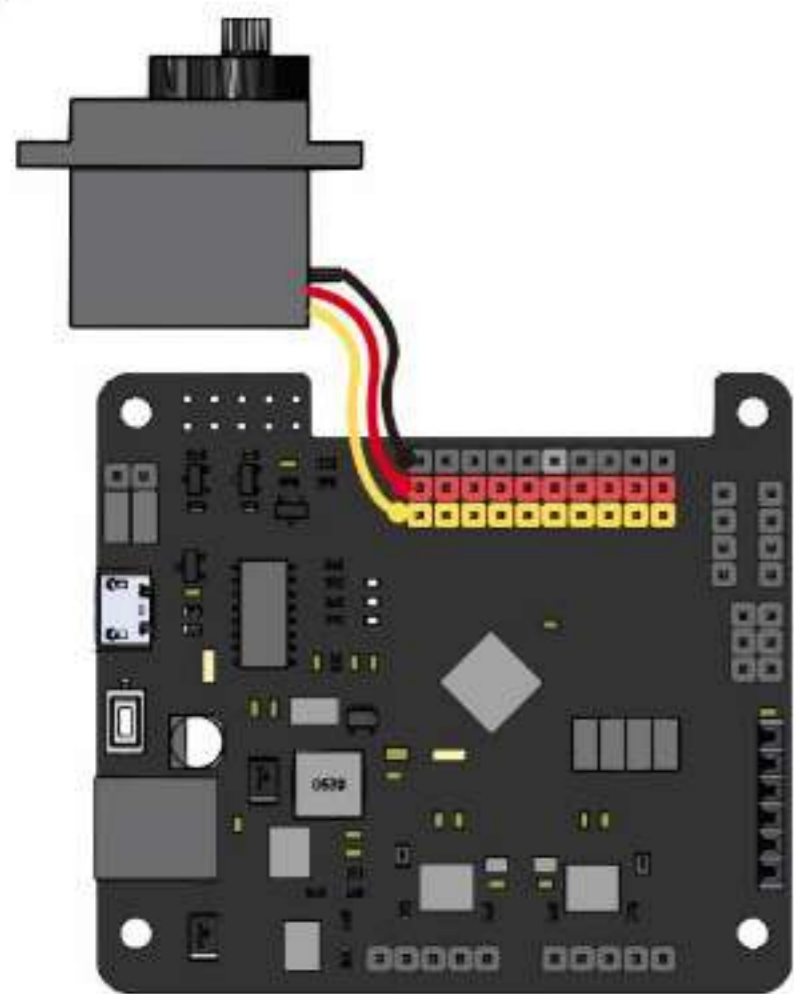

每个舵机安装前必须插接到Rosbot主控板（通电）上进行角度复位
主控板需要提前下载“角度复位”程序！
舵机接线需要注意线序！必须严格按图示进行插接

2

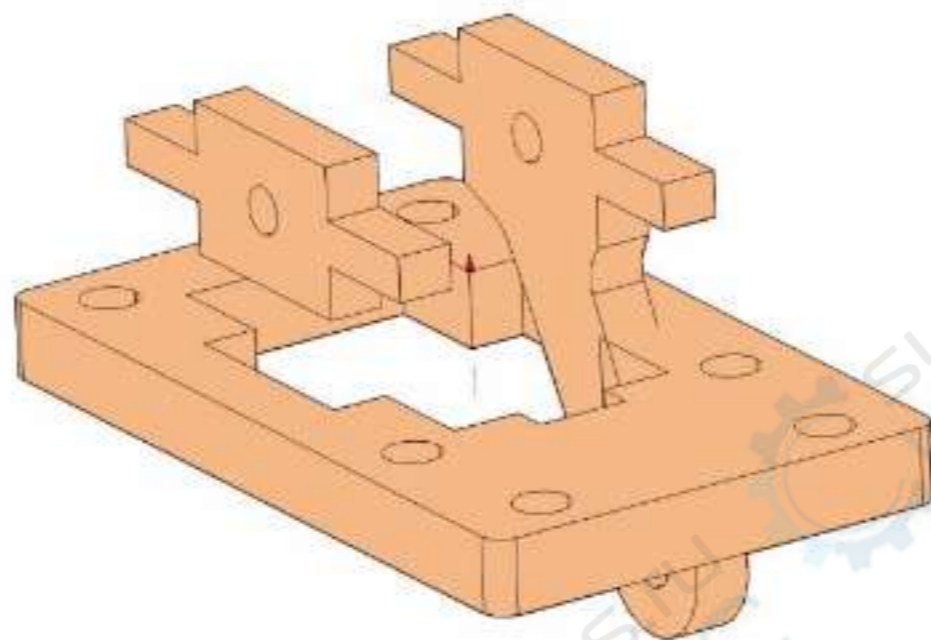

3

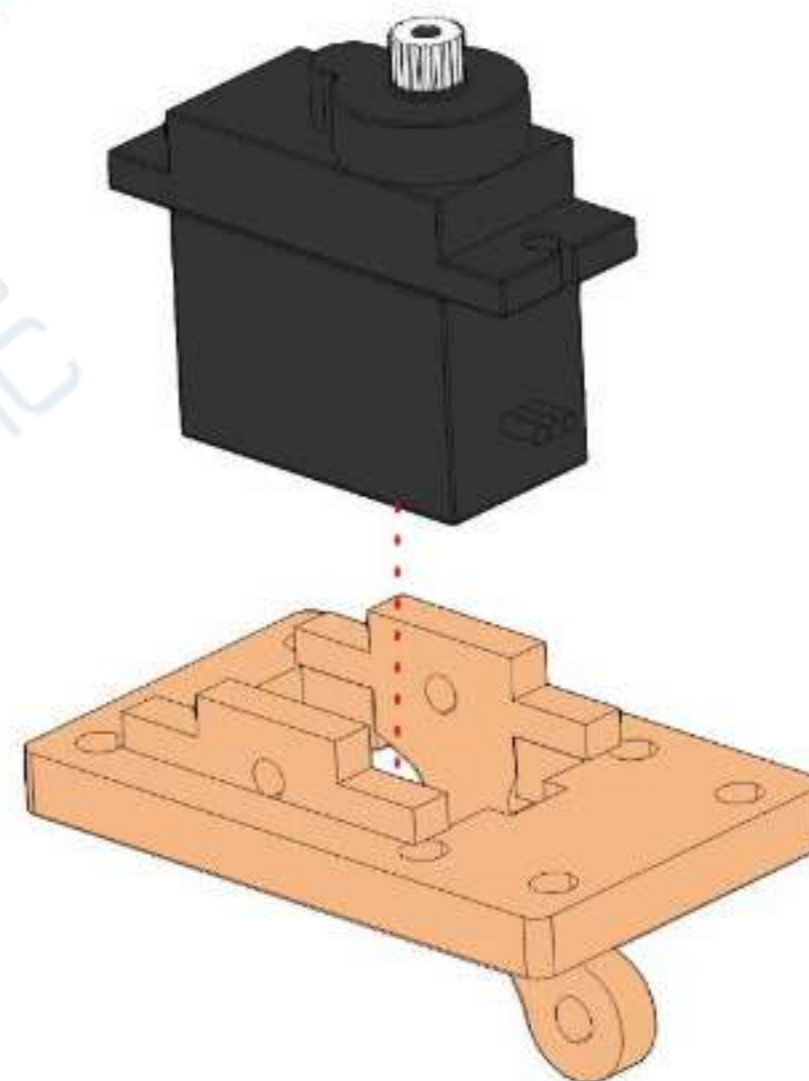

4

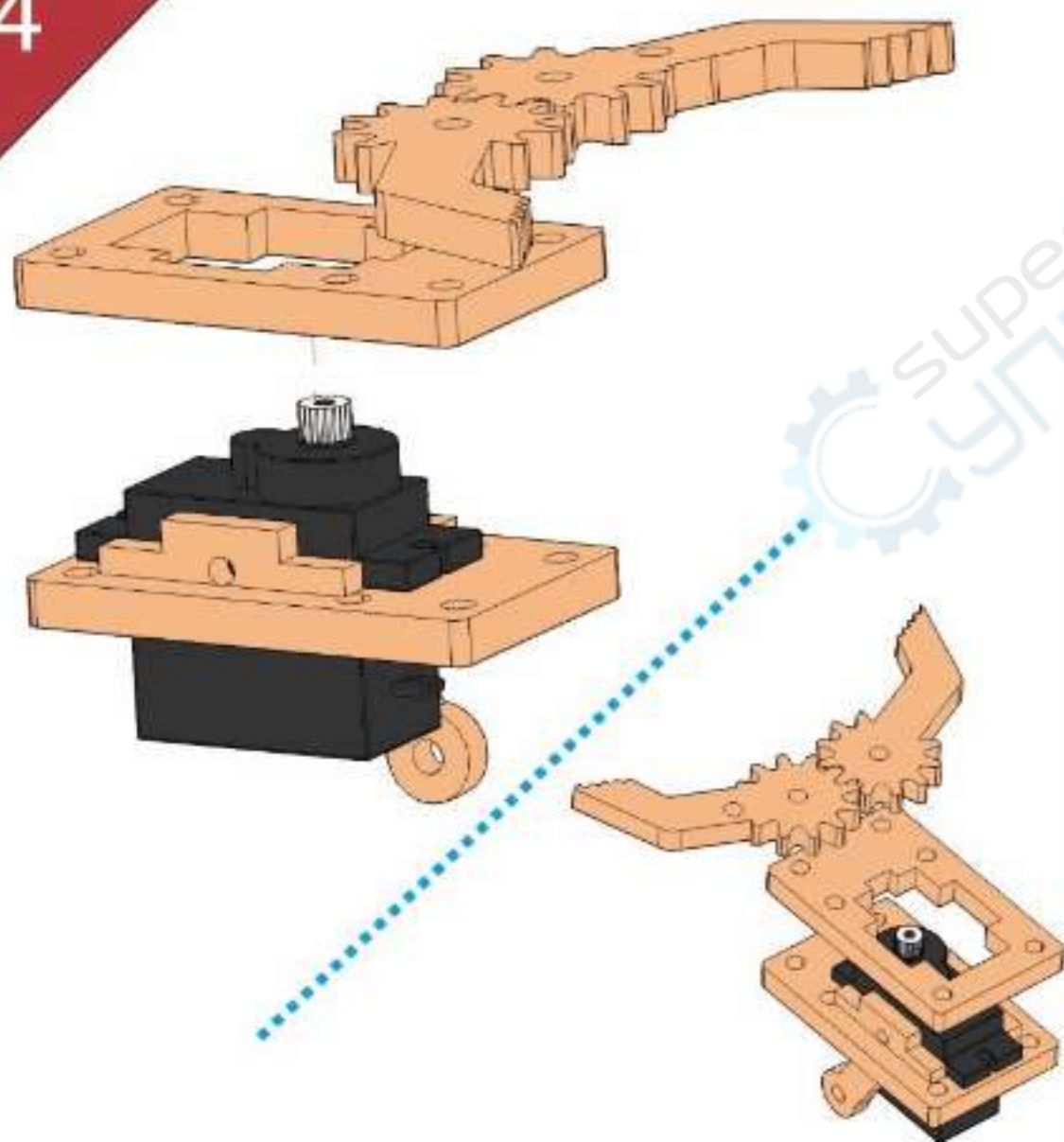

5



6

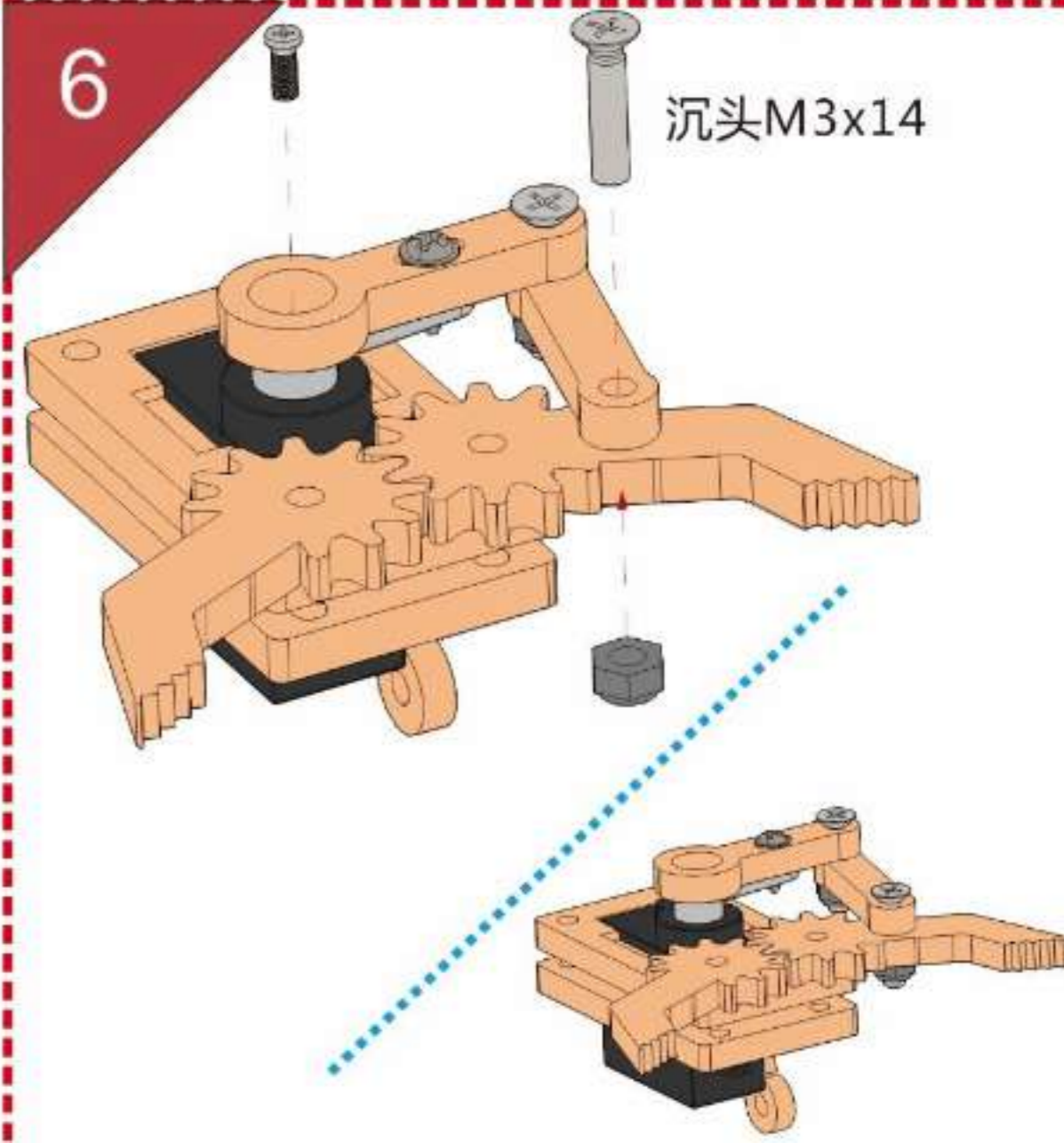

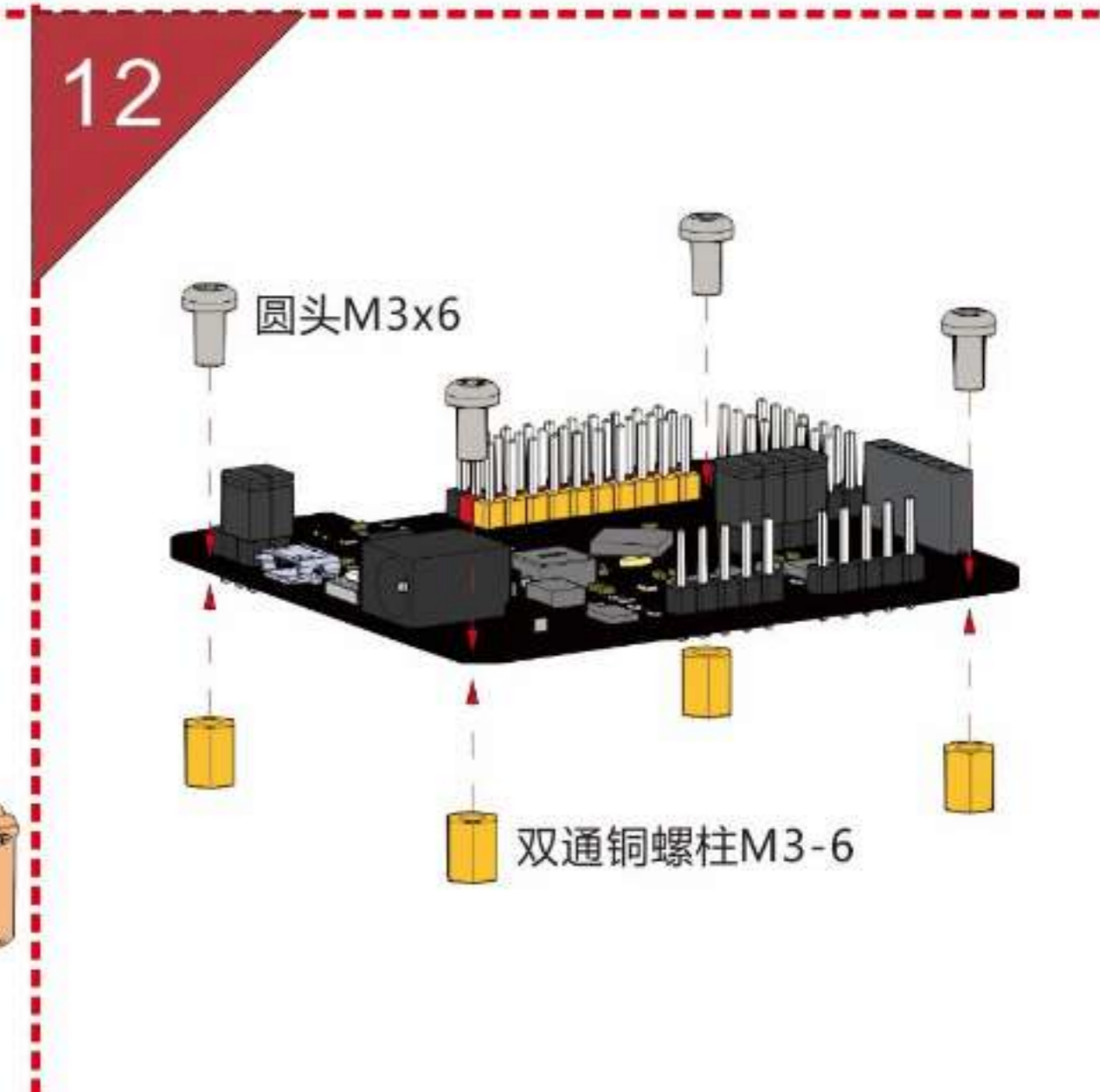
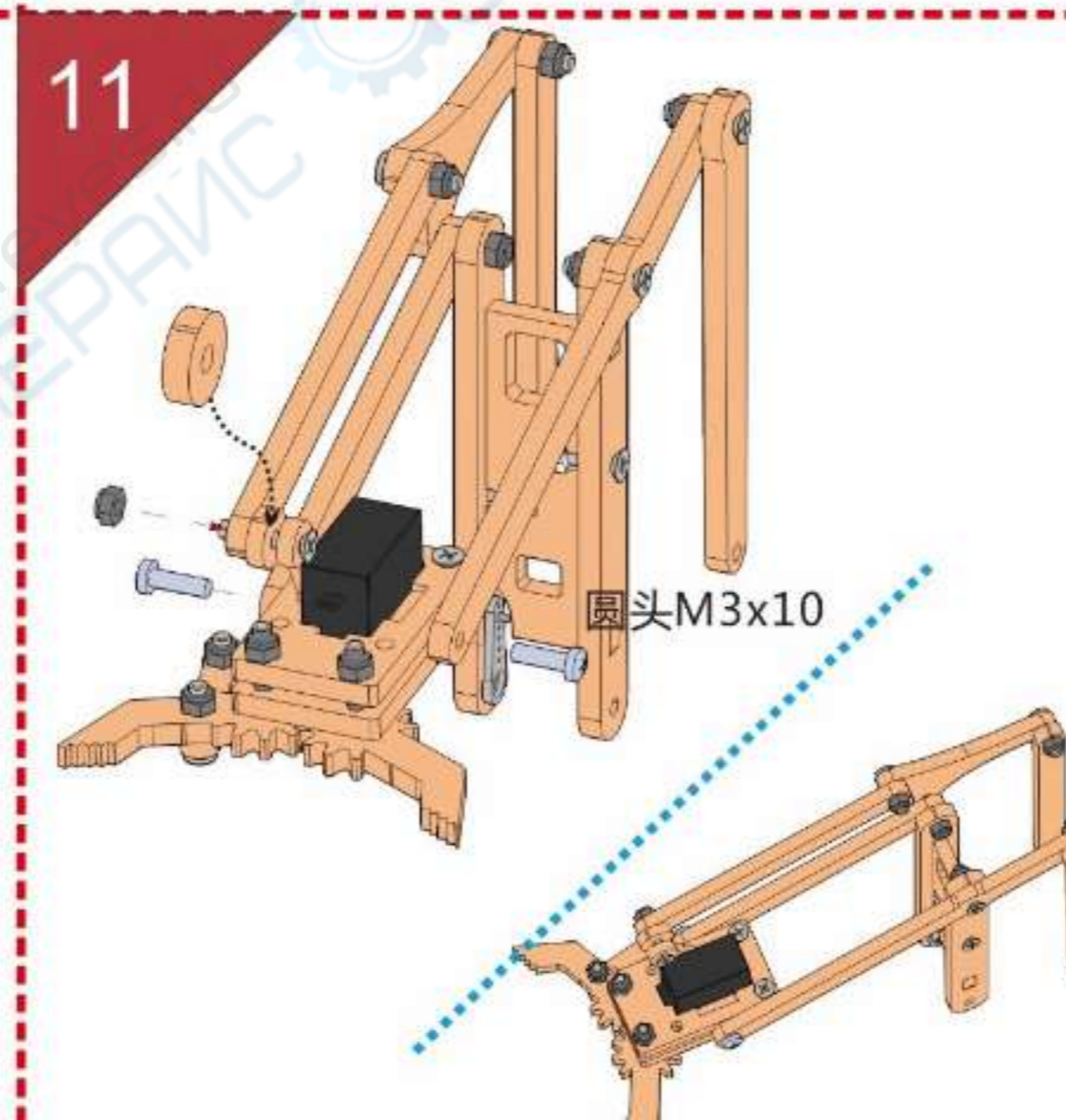
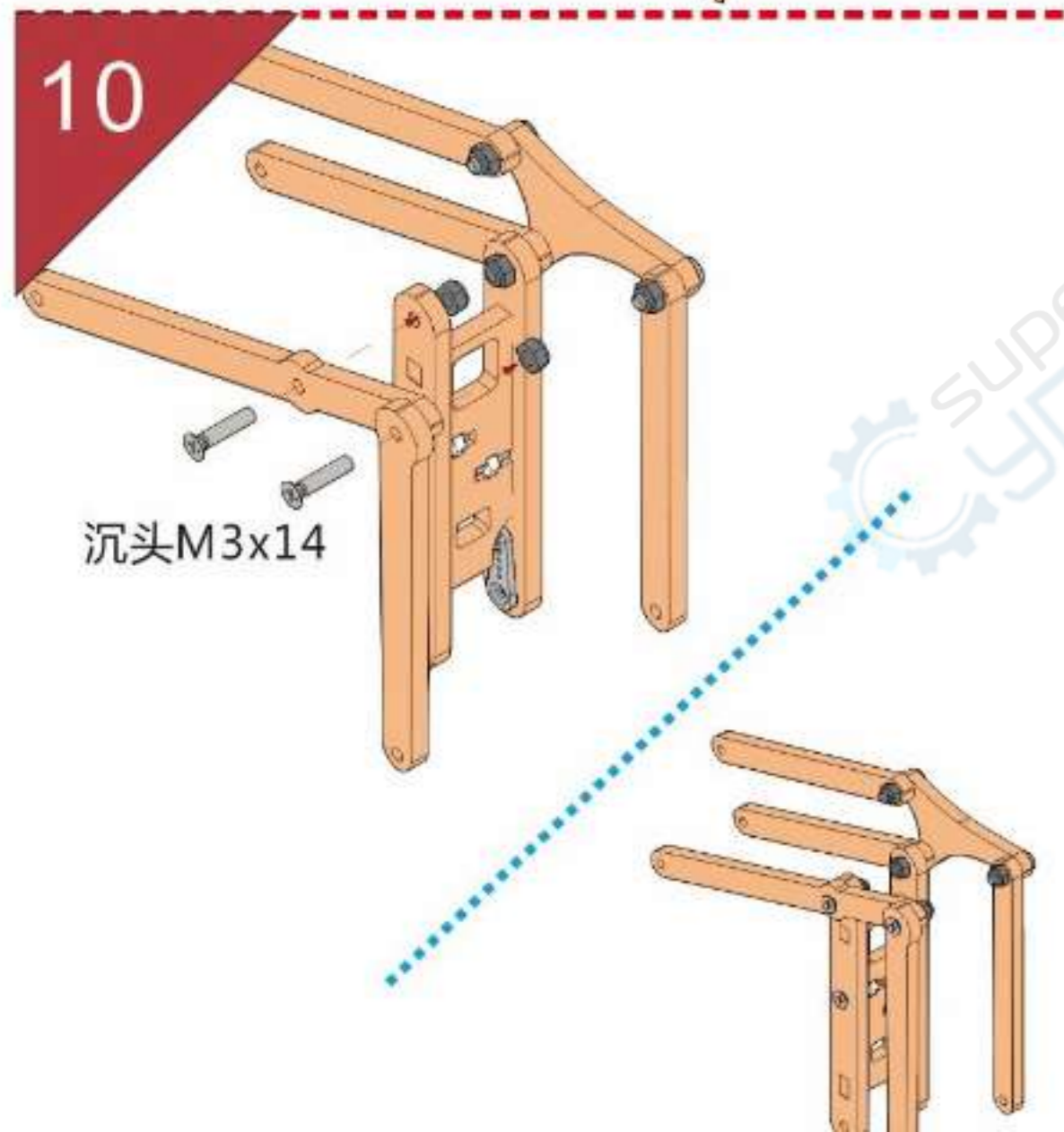
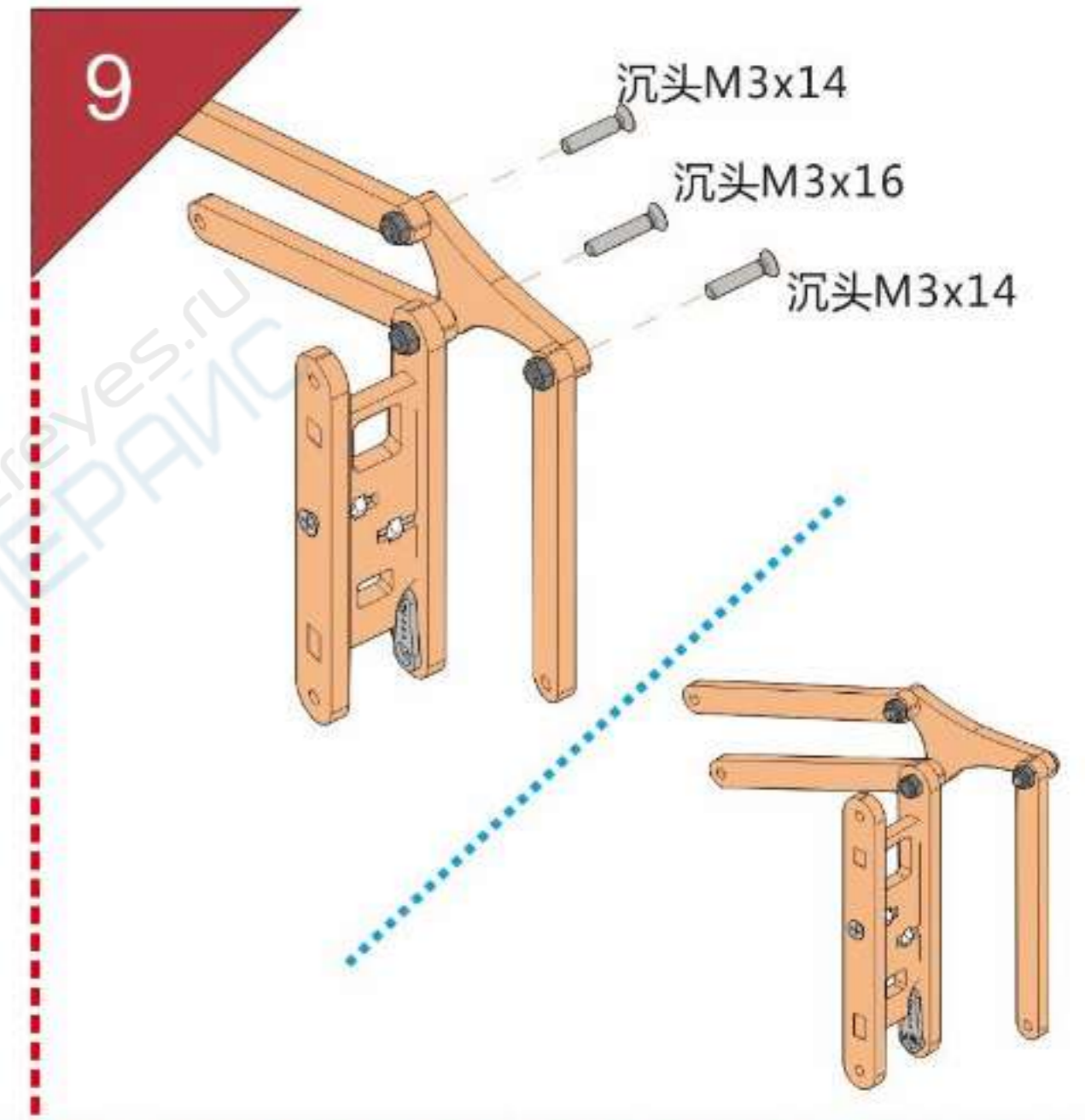
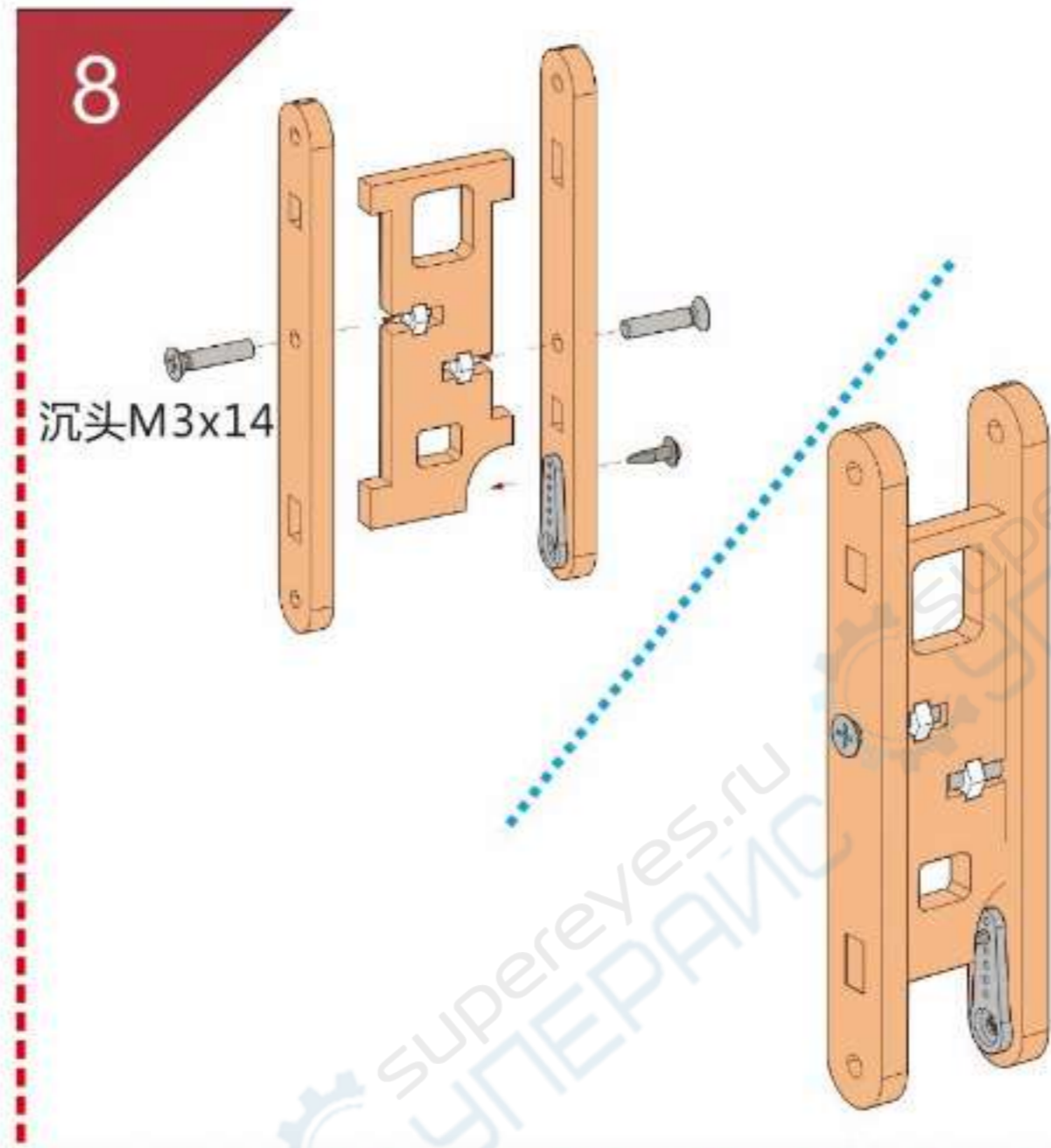
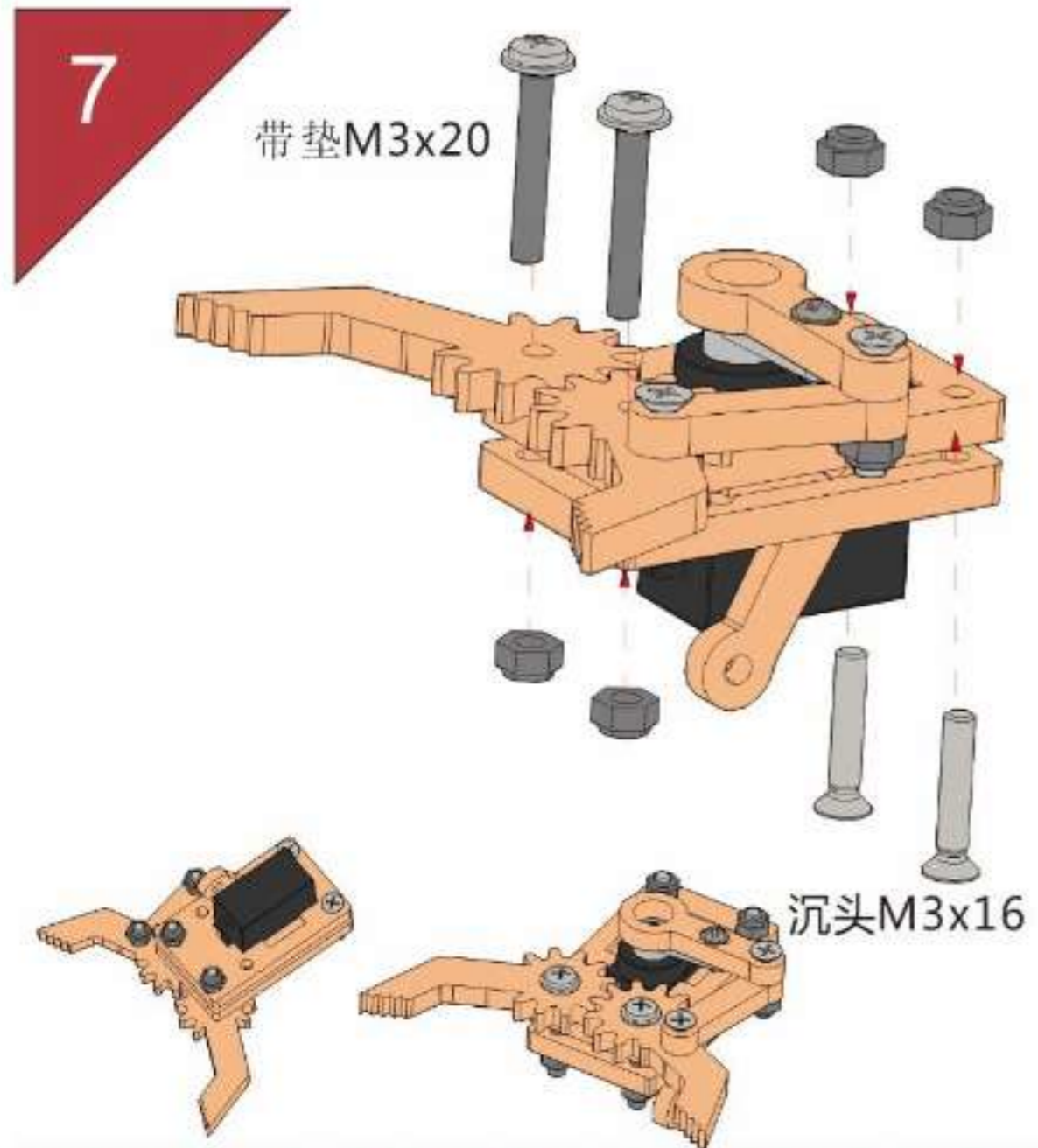

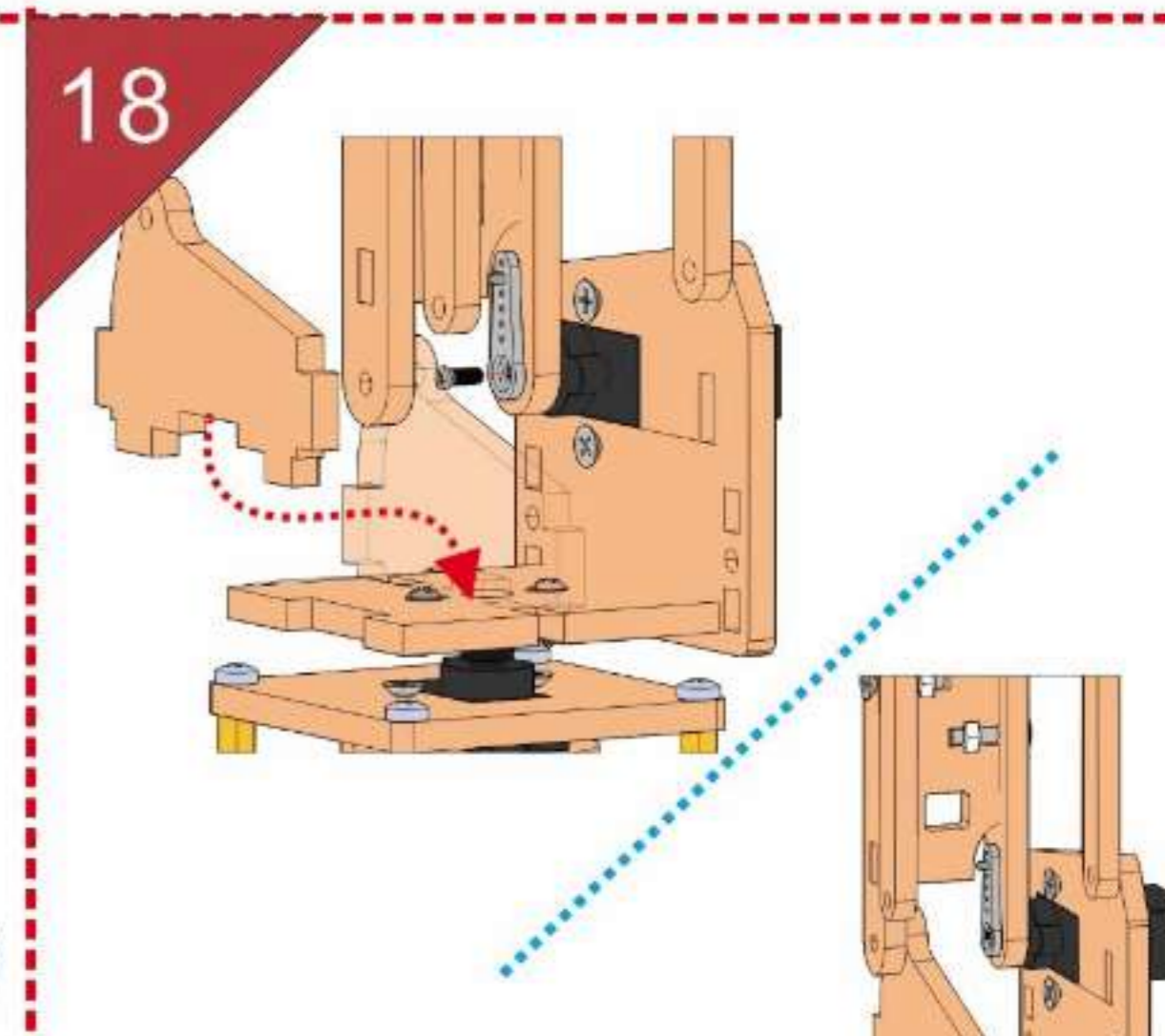
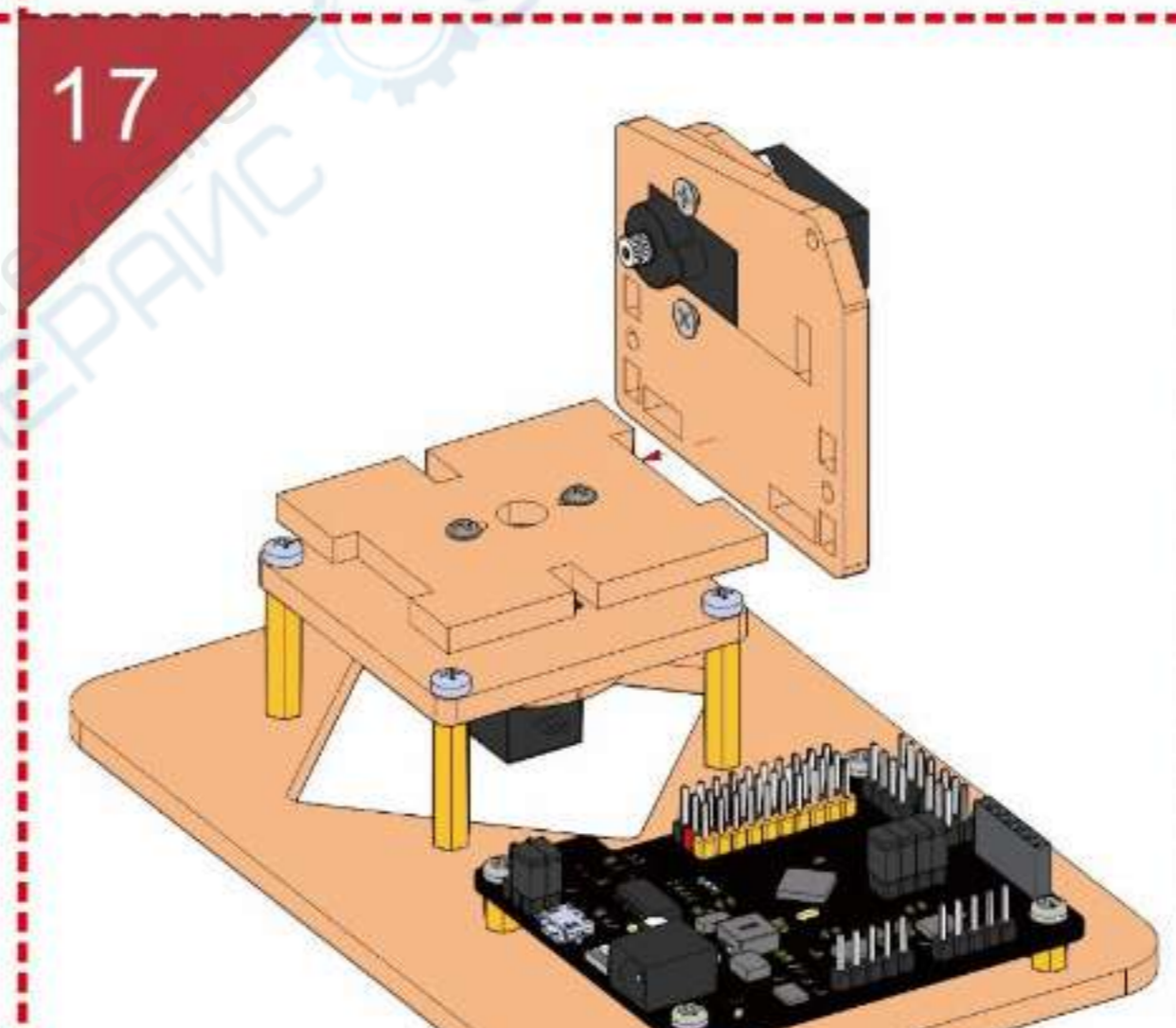
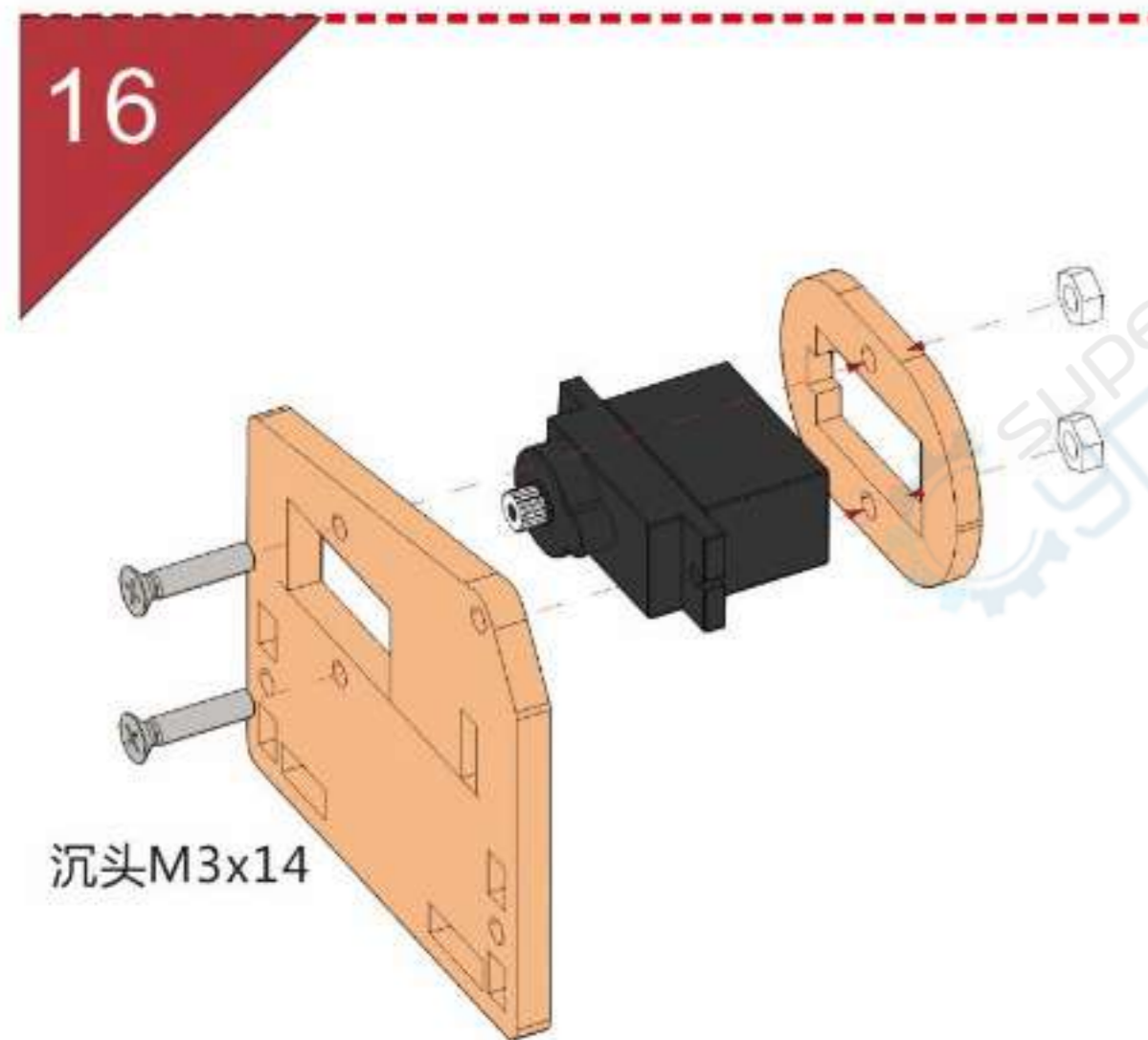
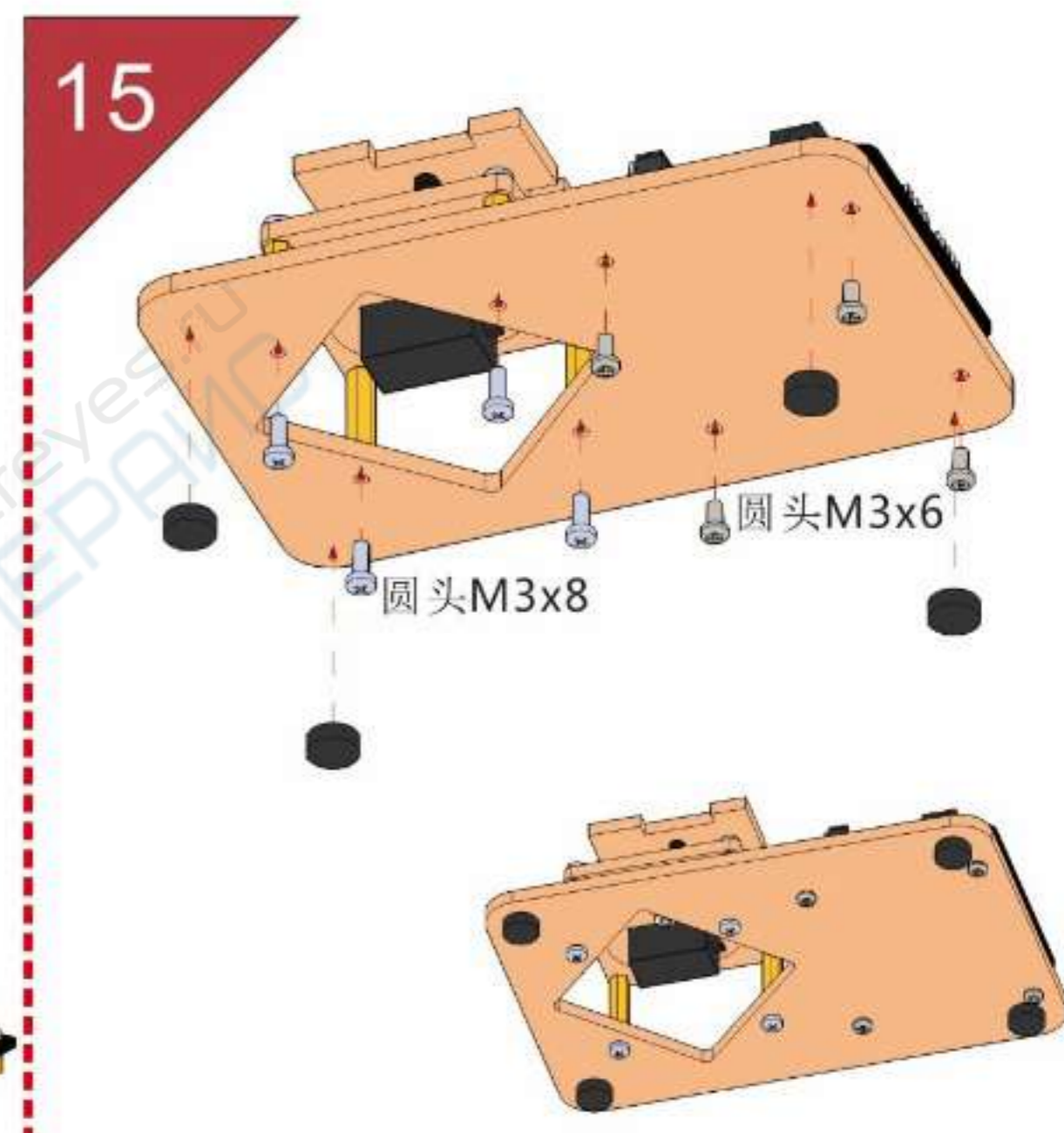
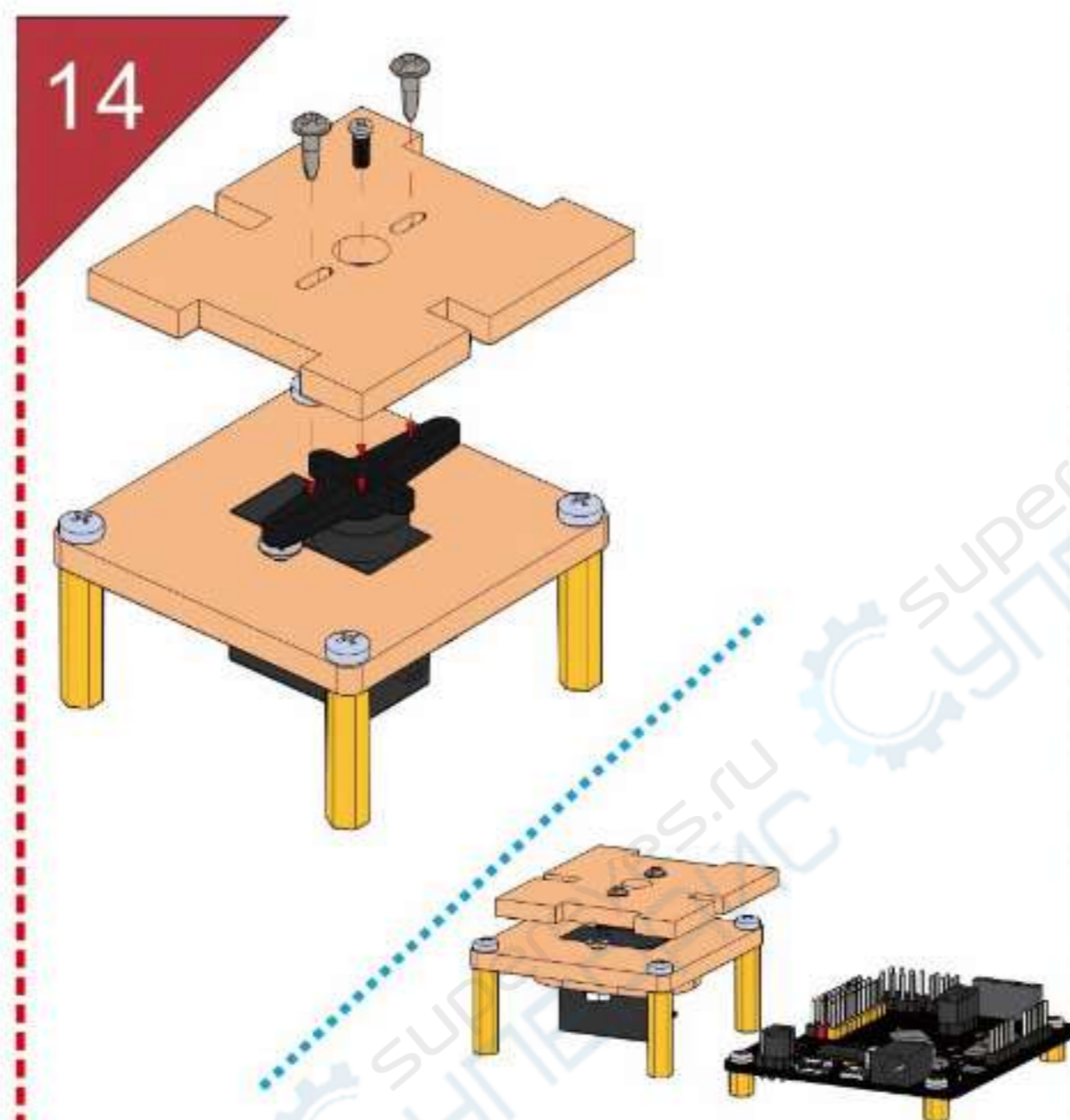
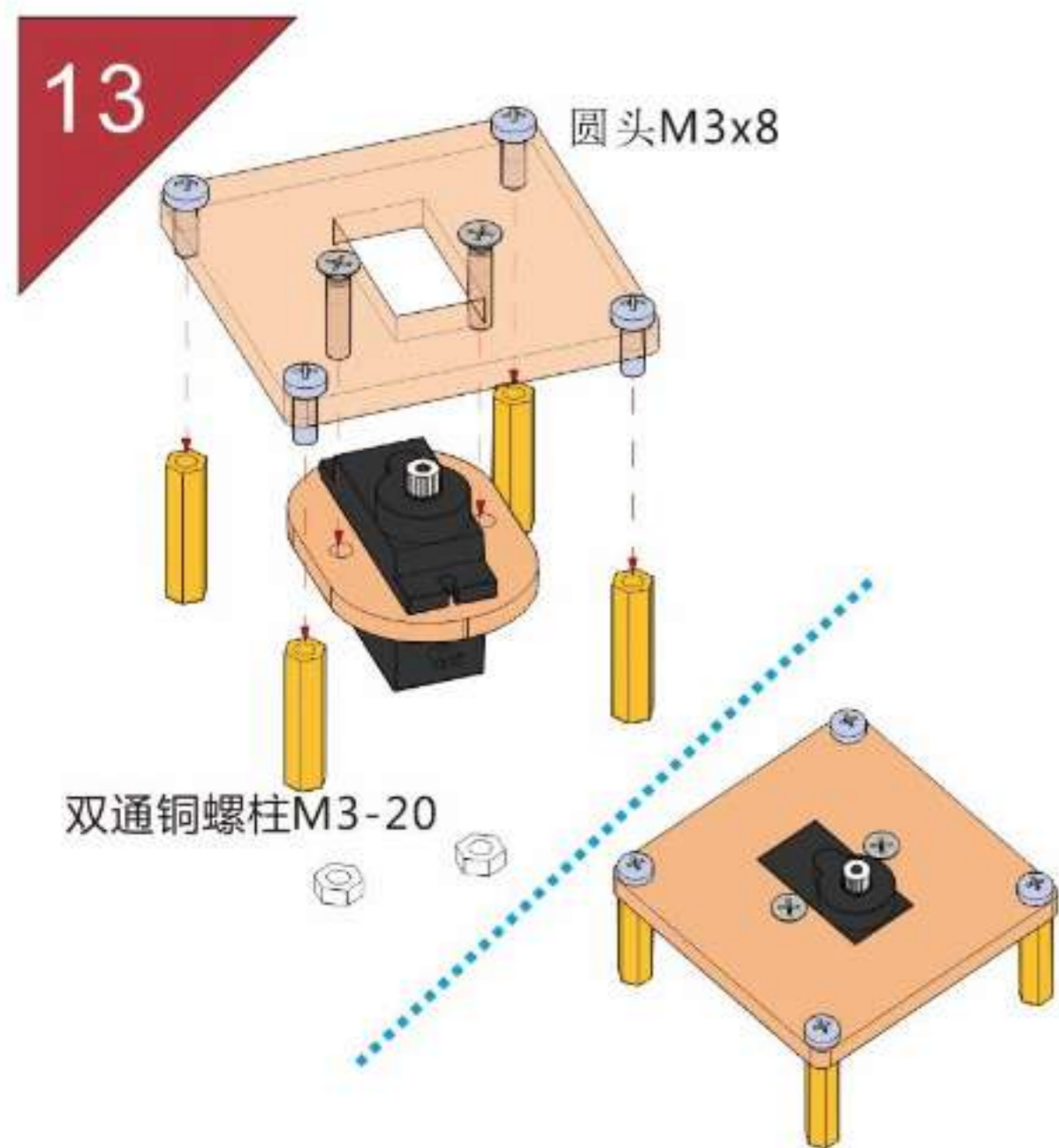

19

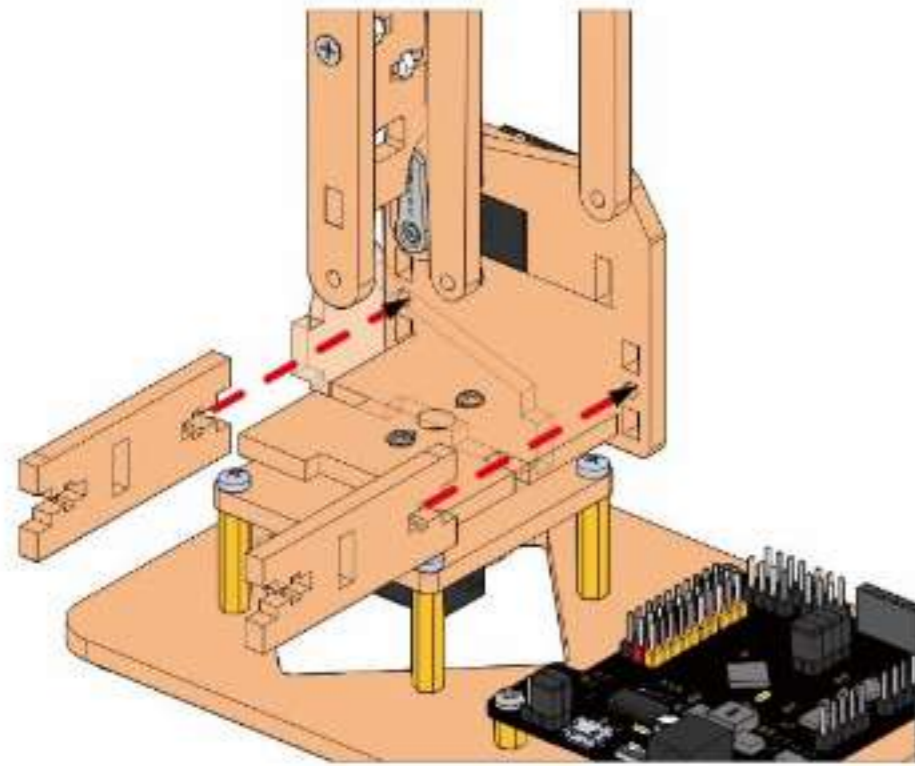

21

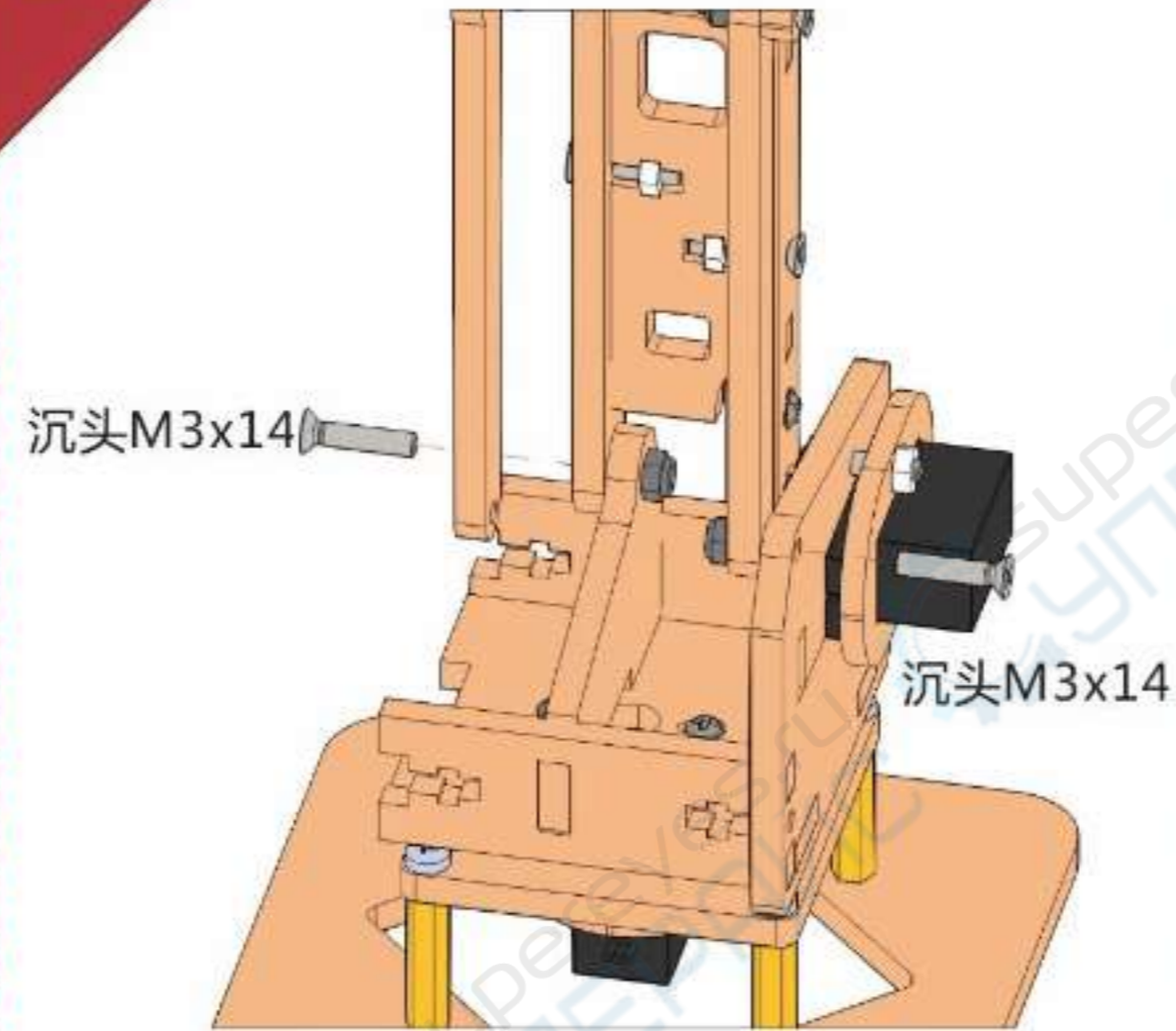

23

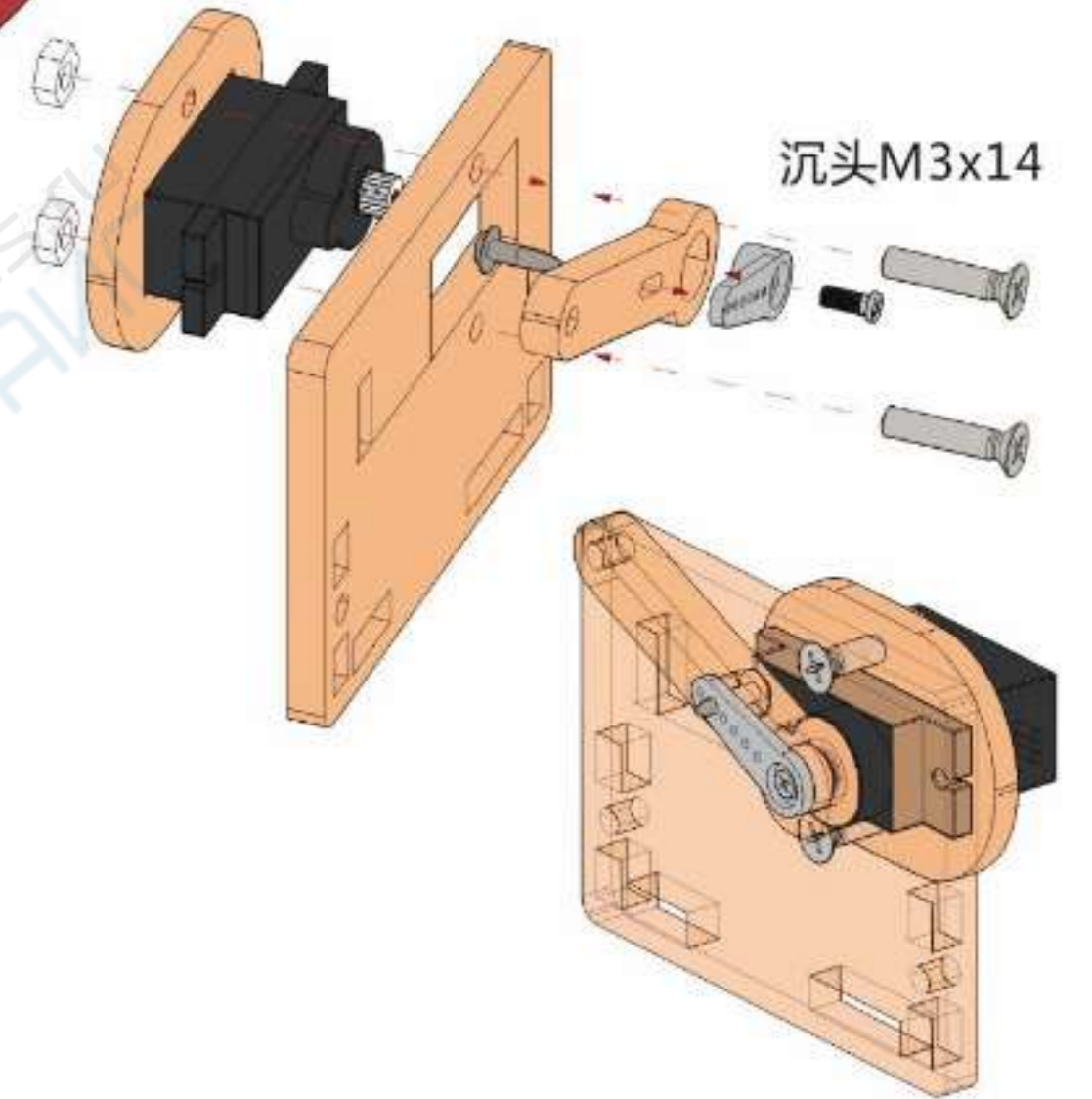

20

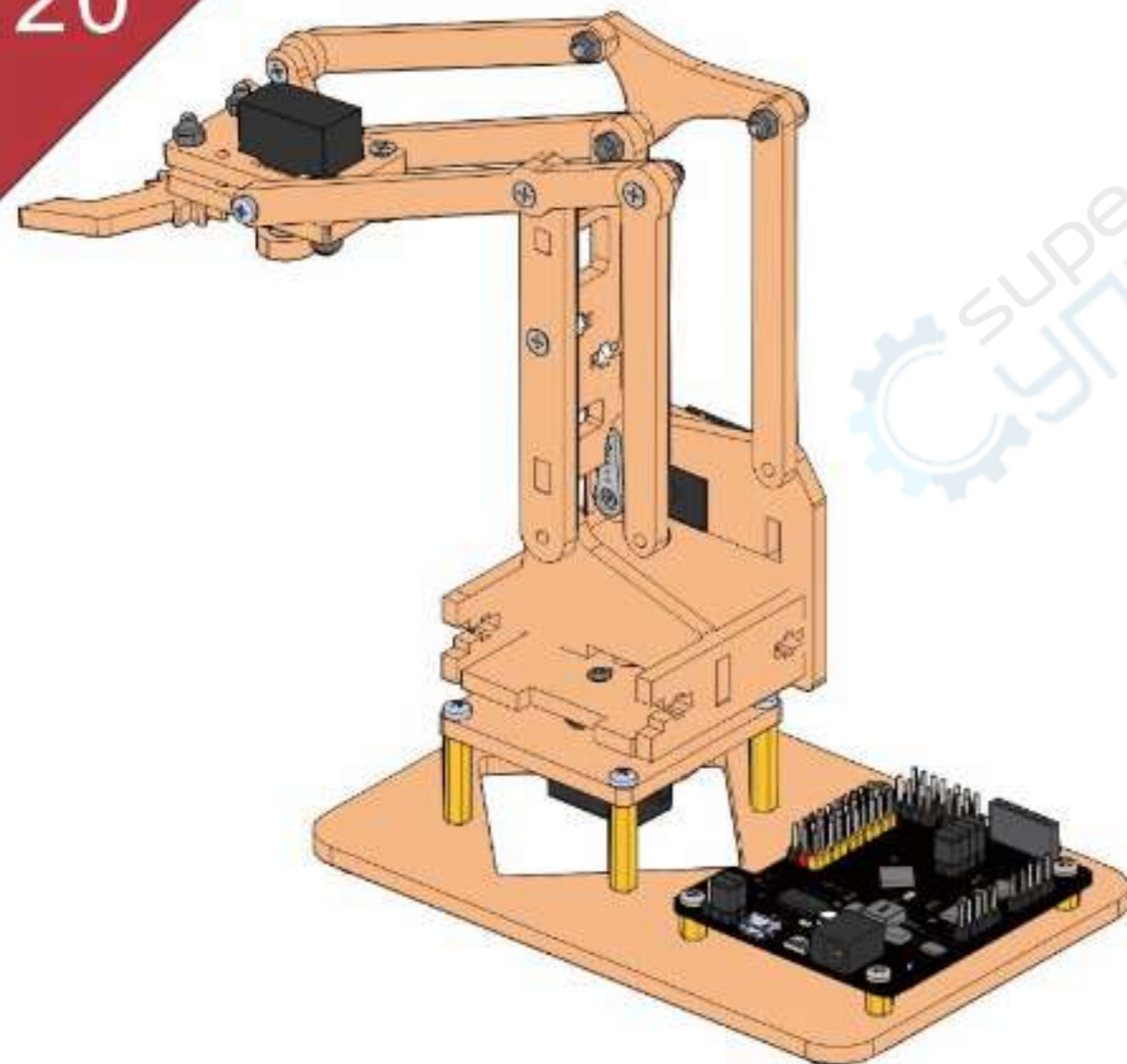

22

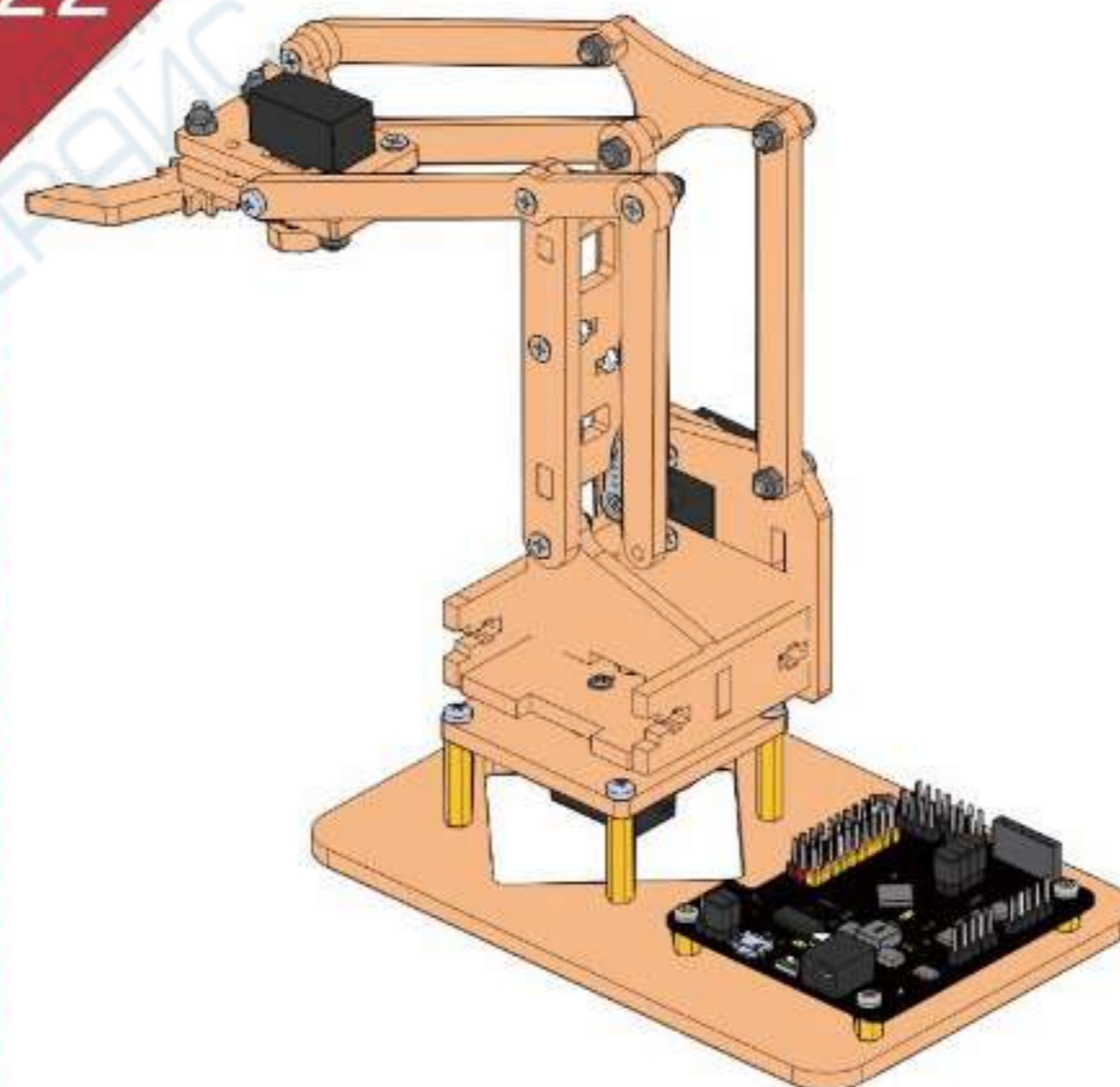

24

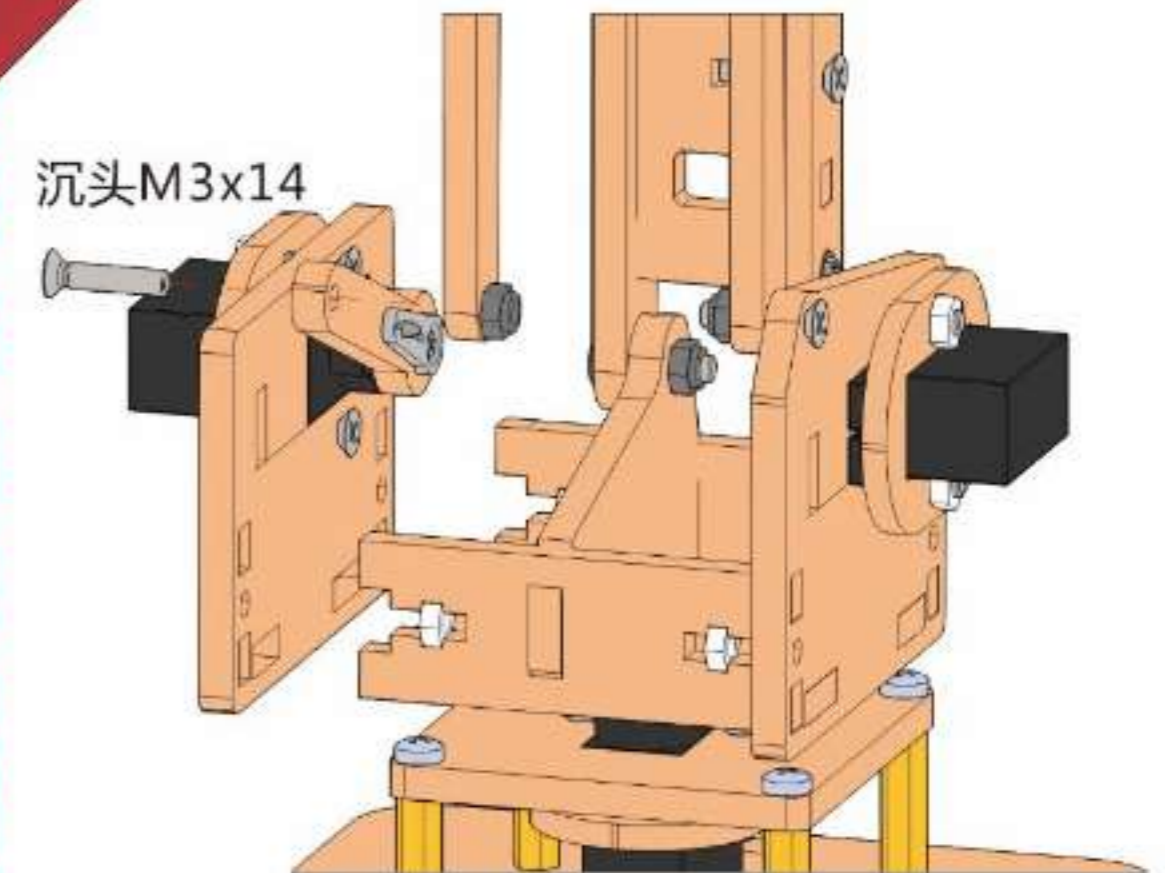

25

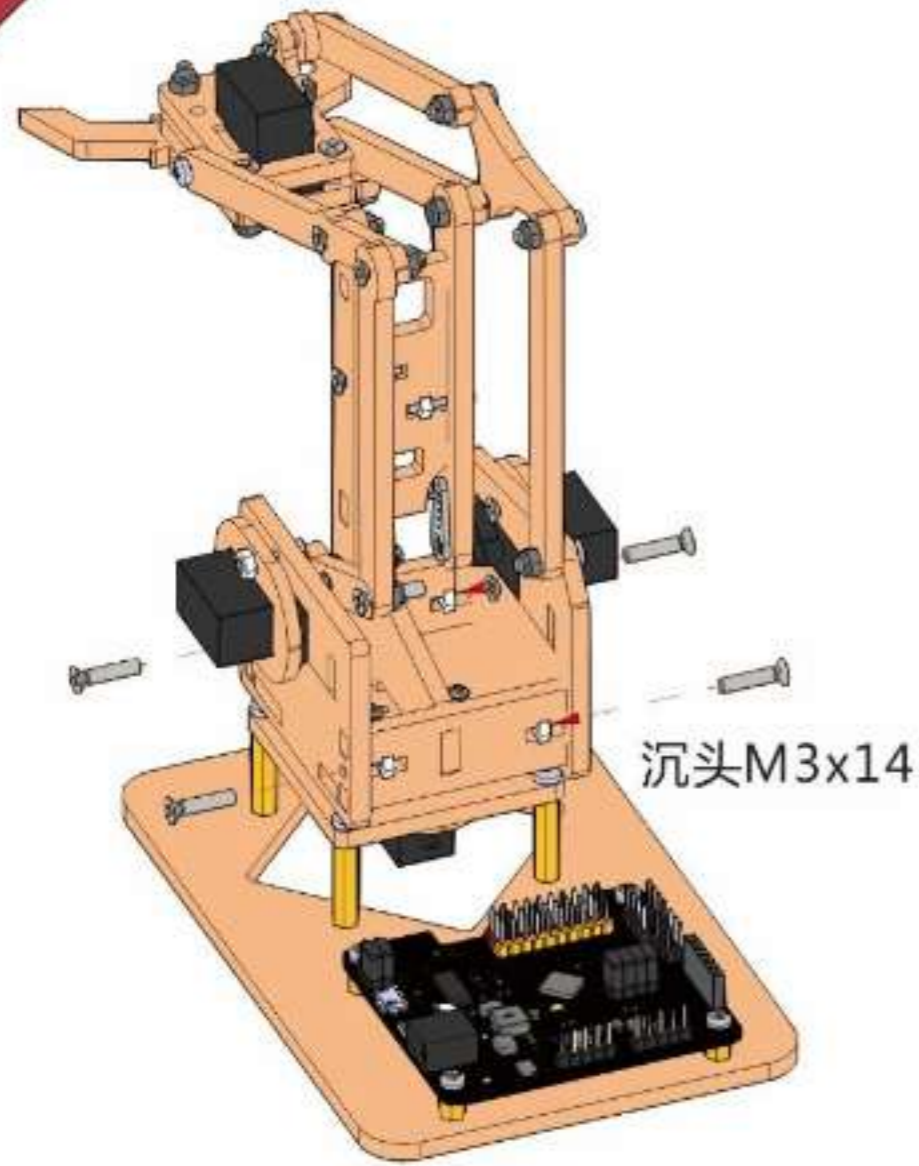

26

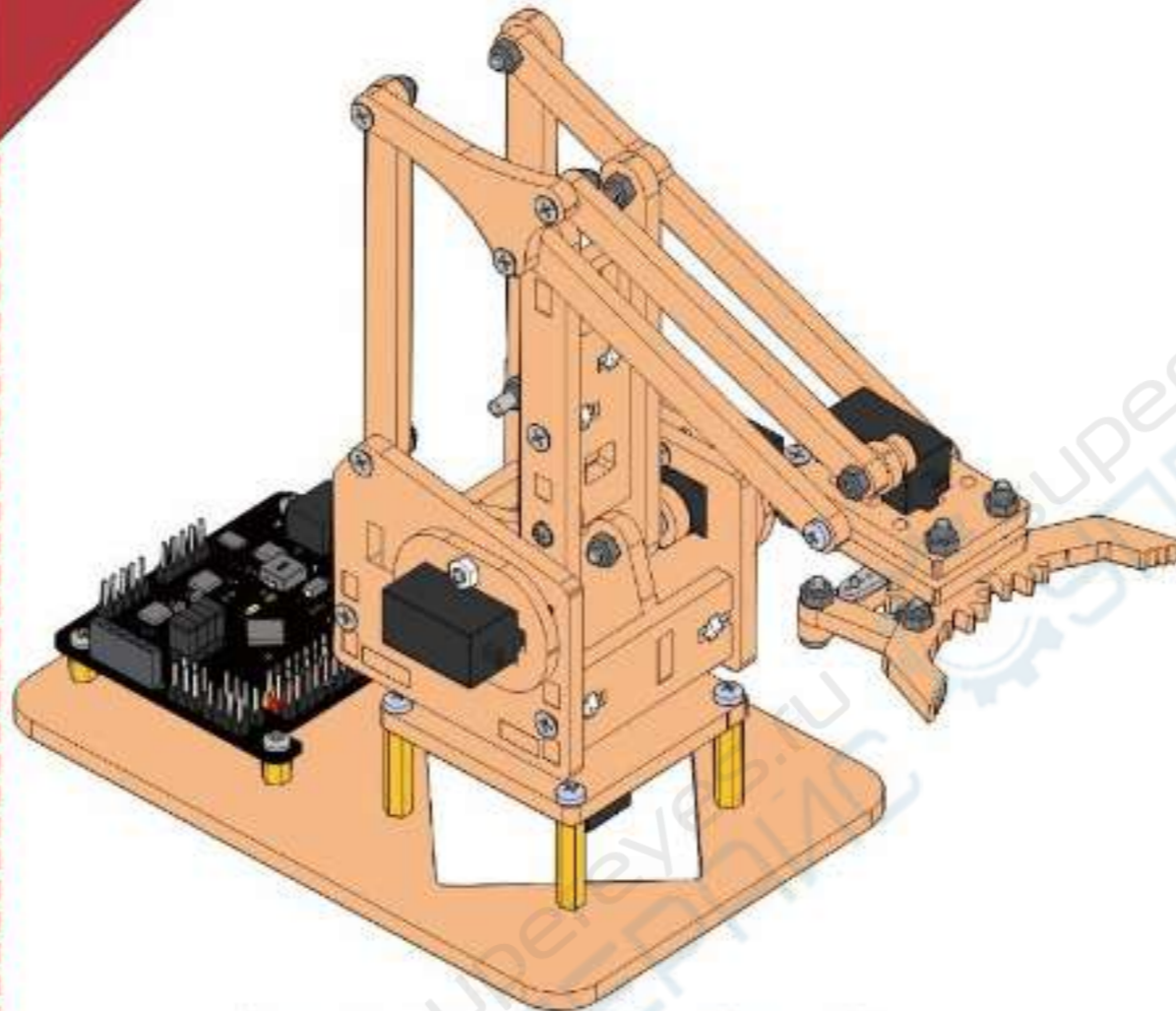

机械组装完成！

27

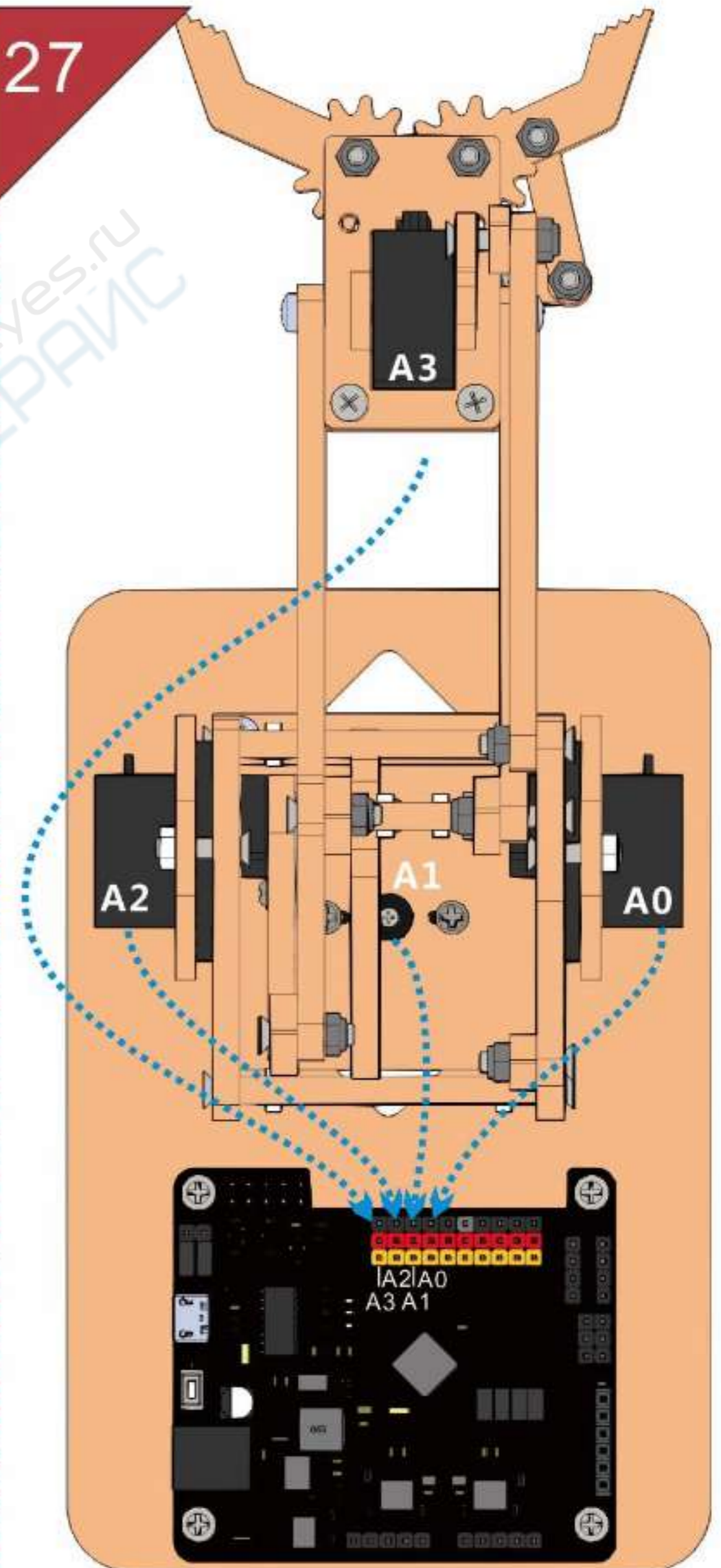

28

编程指引:

由于本说明书的篇幅限制，关于机械臂编程部分详尽部分，
请访问: www.kittenbot.cn/bbs

进入论坛后，右上角搜索框中，搜索“机械臂”
如遇到使用问题，可以在论坛详细描述问题，跟帖留言

舵机接线，如图所示，注意线序，否则导致烧坏板子。
舵机线序参照本说明书开头的步骤1