

欢迎使用













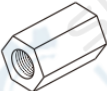

Sunflower 2020 太阳追踪机

安装调试说明

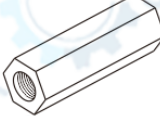
视频教程: <https://www.ixigua.com/i6765878731480236547/>

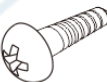
1. 安装

螺丝清单

活动关节/机架/ 铜柱/底座的固定 S023005	 	X 15	
固定Arduino主板 S063004	 	X 4	
Arduino主板铜柱 T3006		X 4	
底座铜柱 T3018		X 4	
光敏模块固定螺丝 S042310		X 4	
舵机固定螺丝 S042308		X 4	
舵机轴固定机架螺丝 S042005		X 2	

附件包内的螺丝很多种型号，请务必区分清楚再动工。

有几种很相近的螺丝，不要混用。

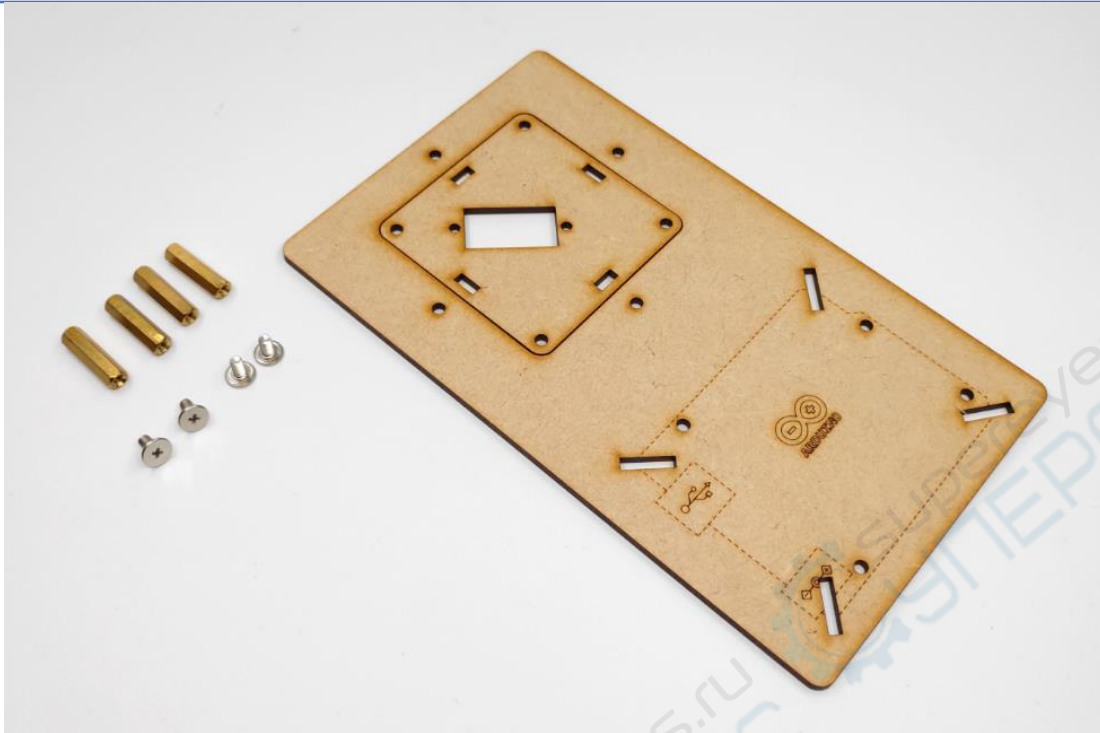

只看图片就可以安装，有文字的地方是曾经手残党安装有错误的地方，提醒注意。

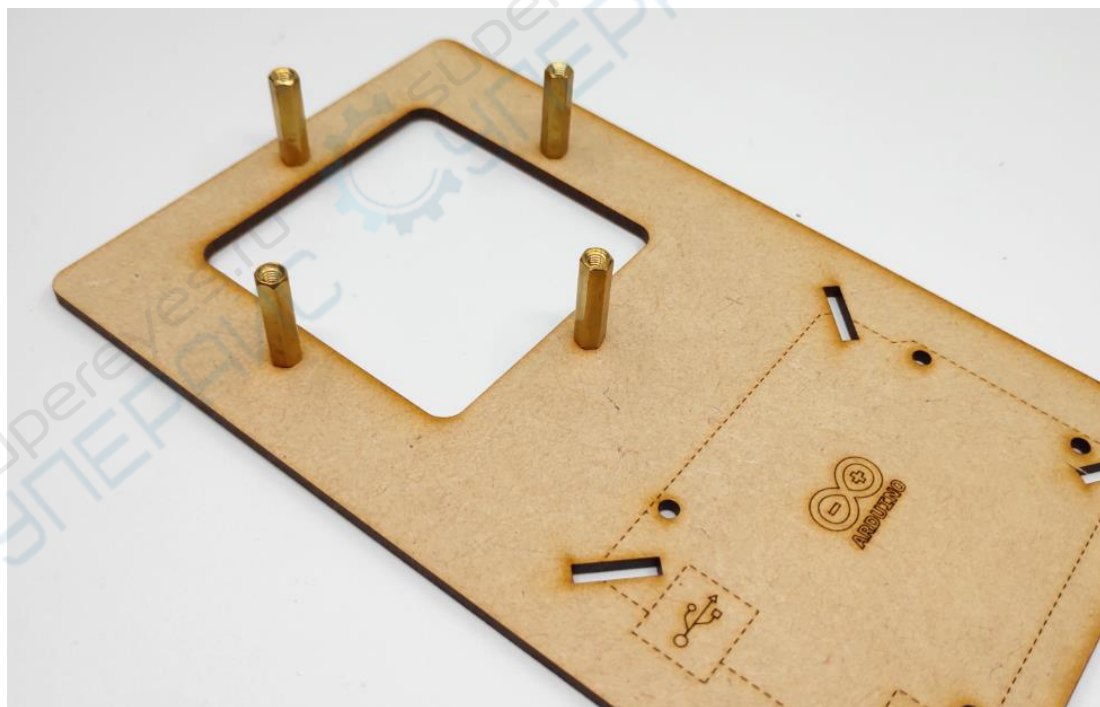

用螺丝从底部固定铜柱

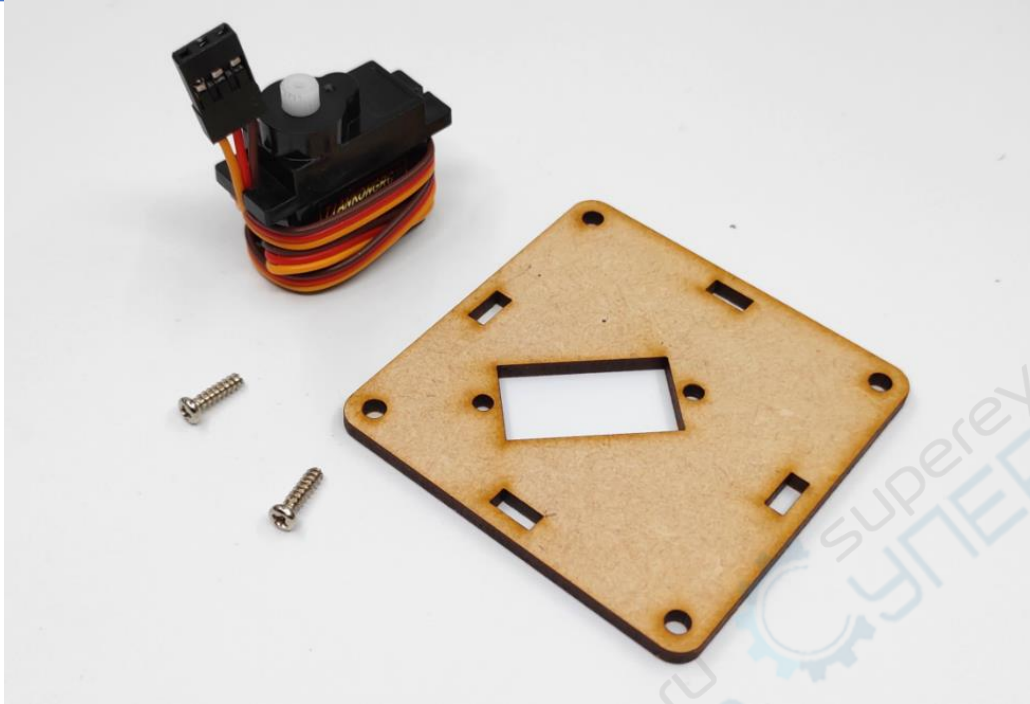

固定舵机的螺丝是小帽粗牙螺丝。

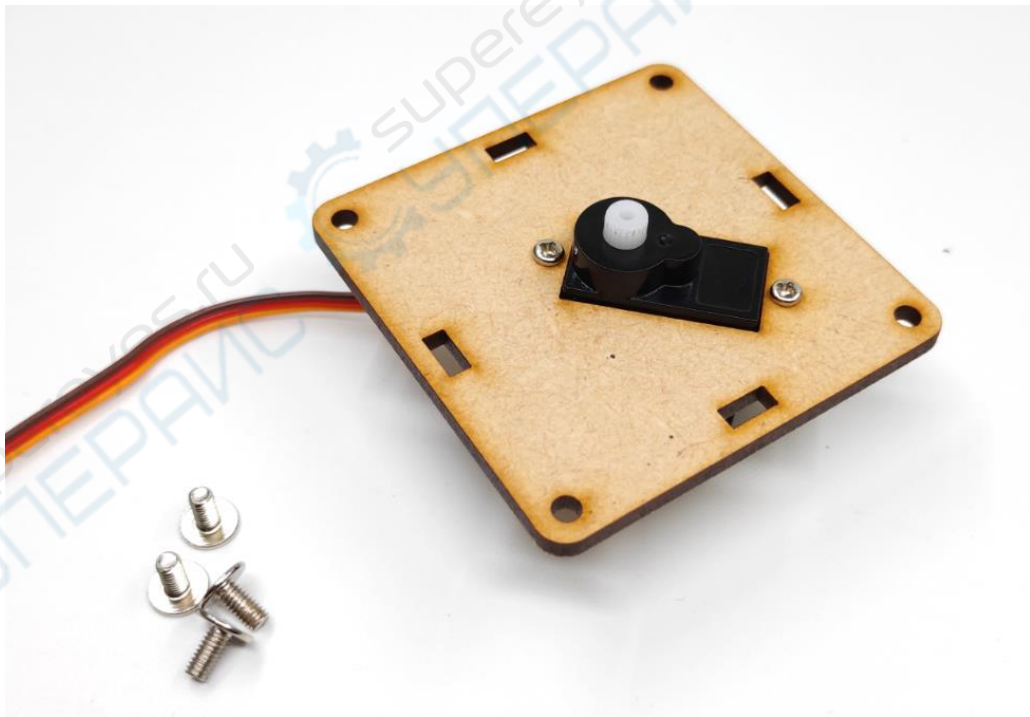

注意：舵机朝向，主轴在底座的中心。

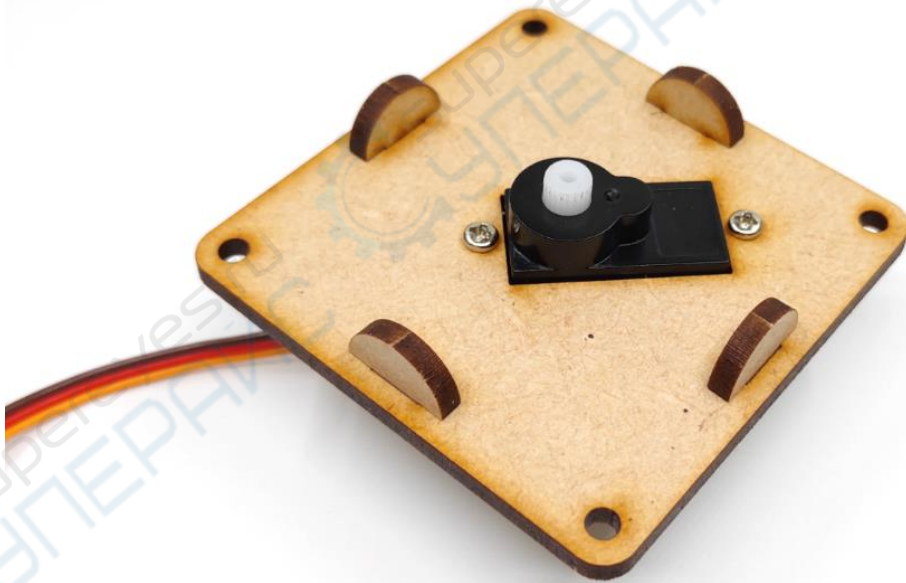
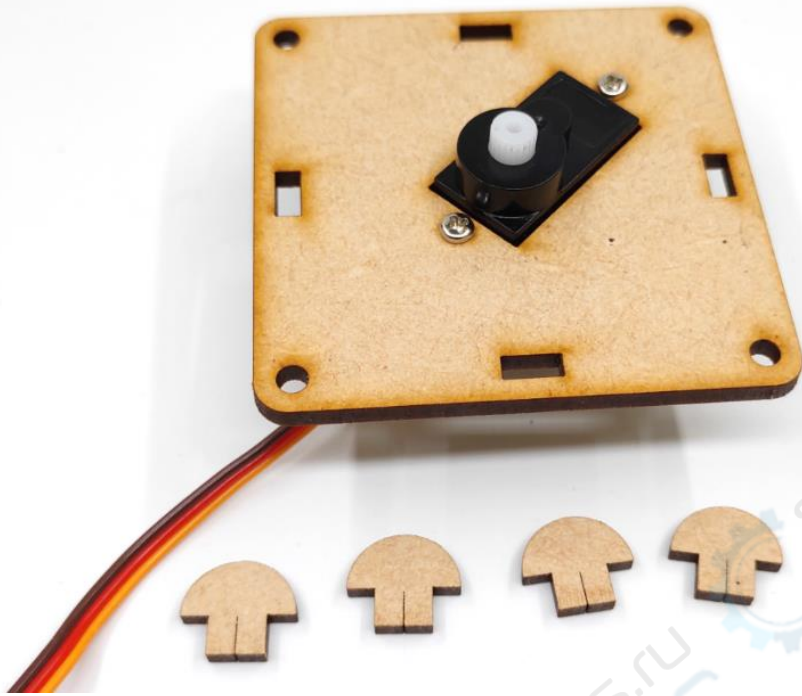

supereyes.ru
СУПЕРПАВК

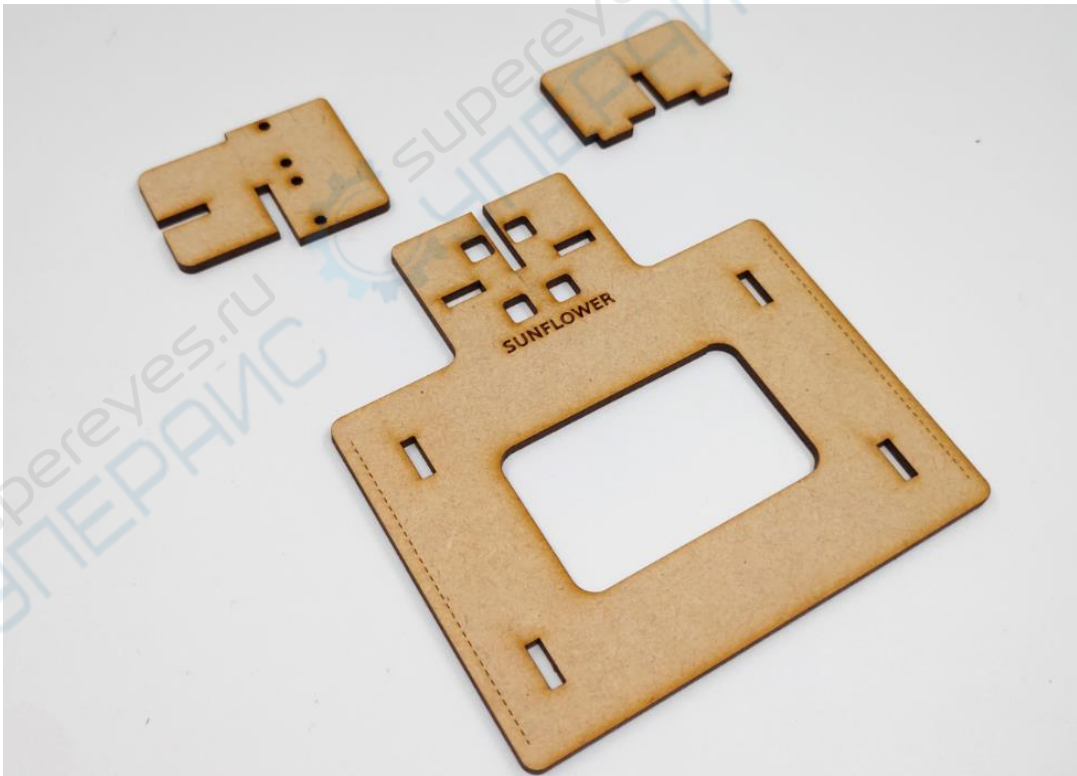
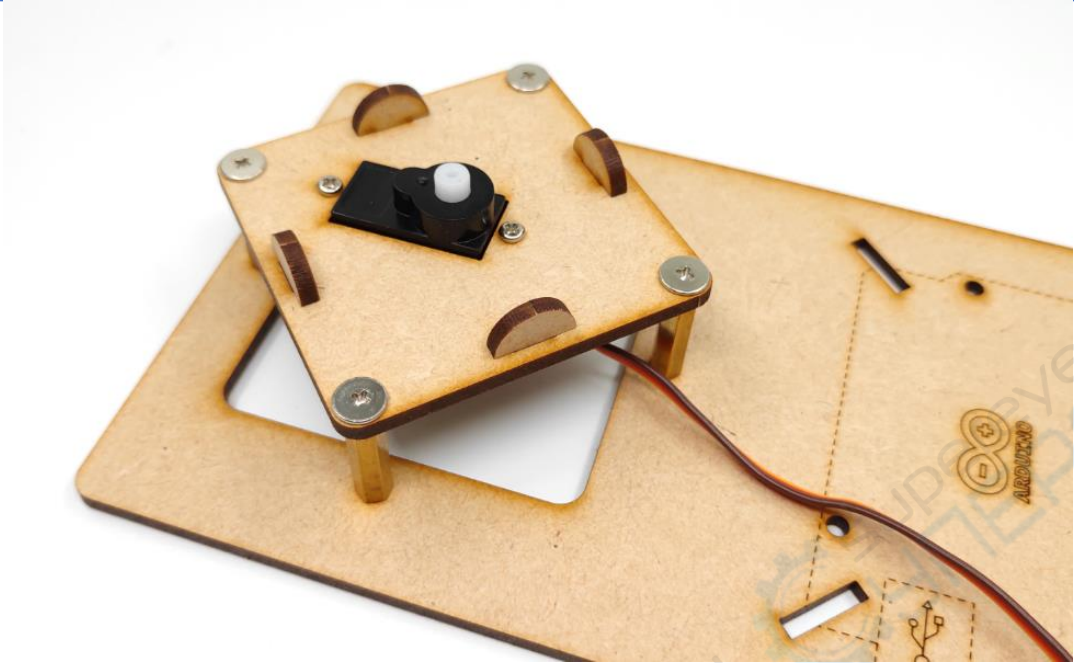

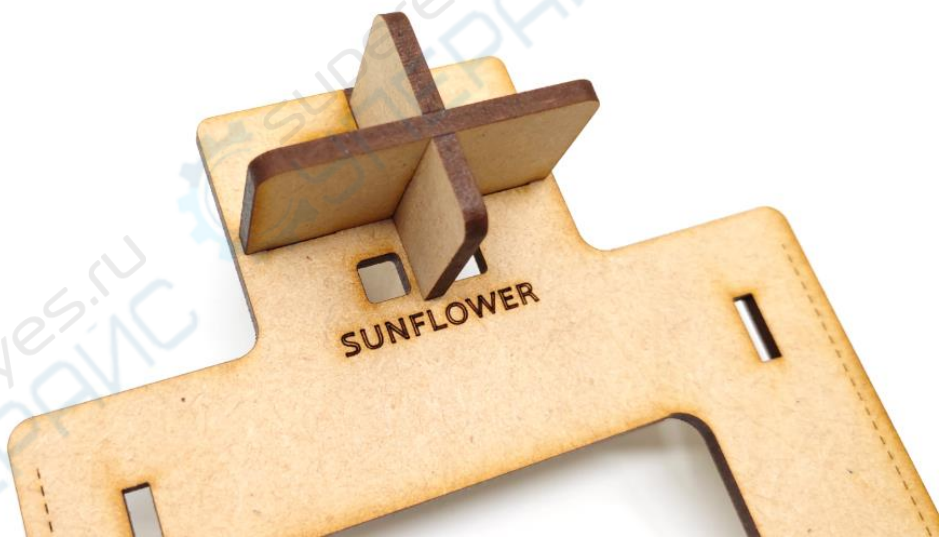
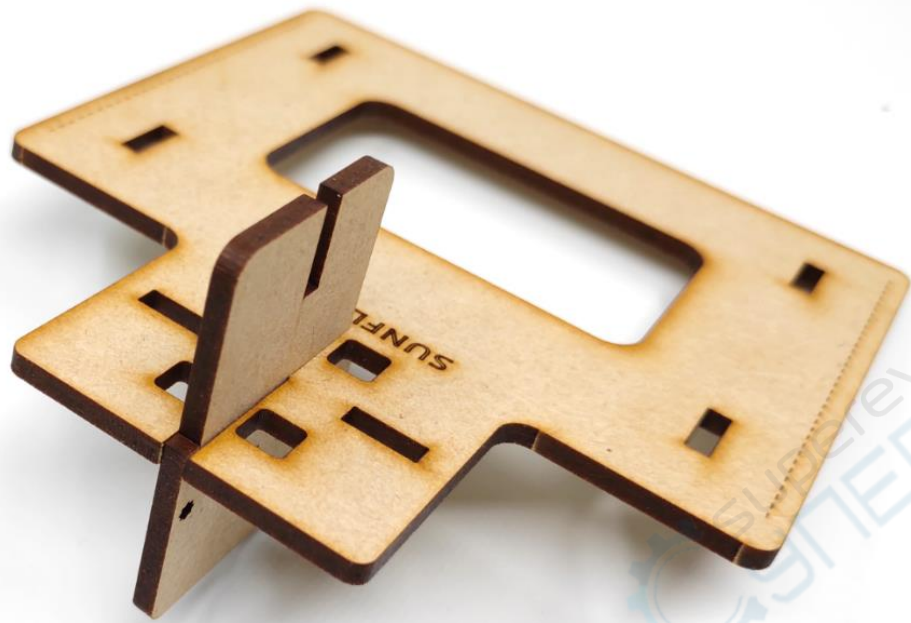

supereyes.ru
СУПЕРПАВЛ



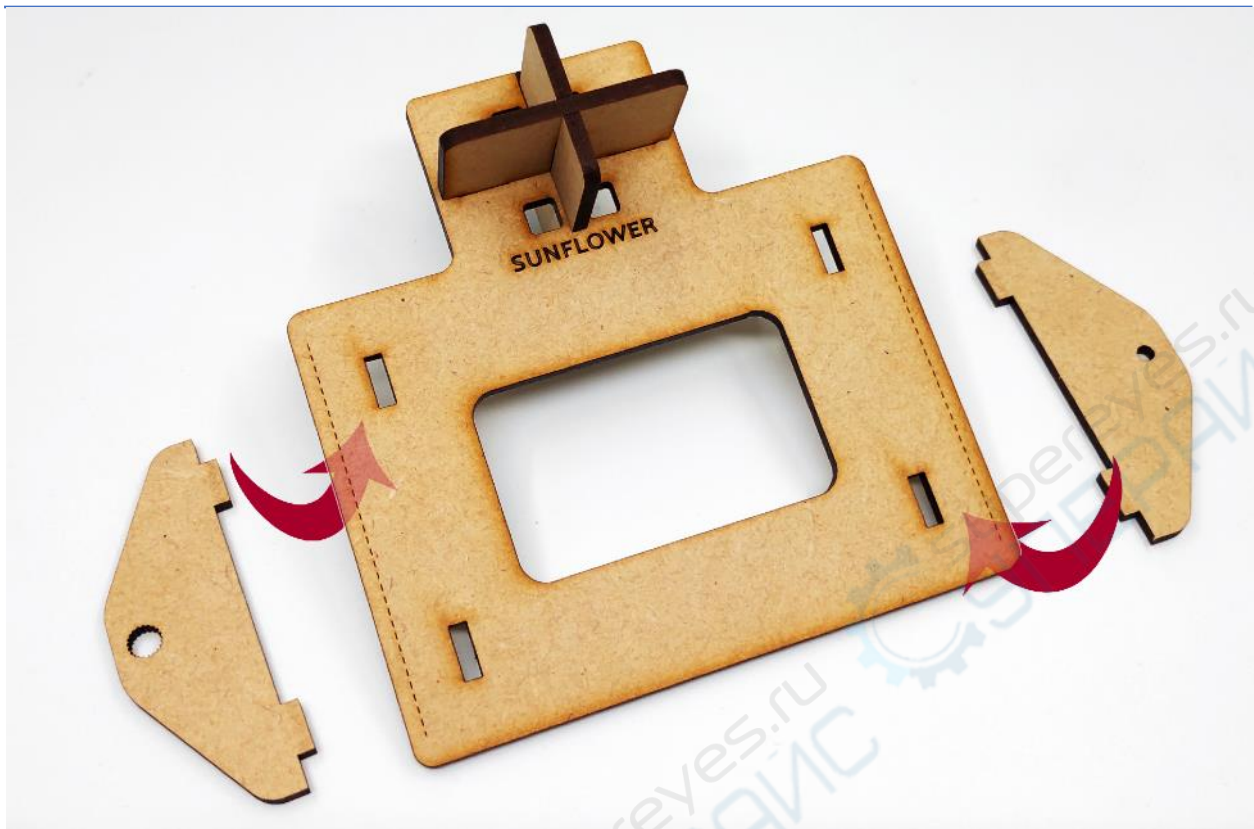

两片侧支架从背部安装，2020 版增加了防呆插口，左右两片有固定位置，不会插翻。



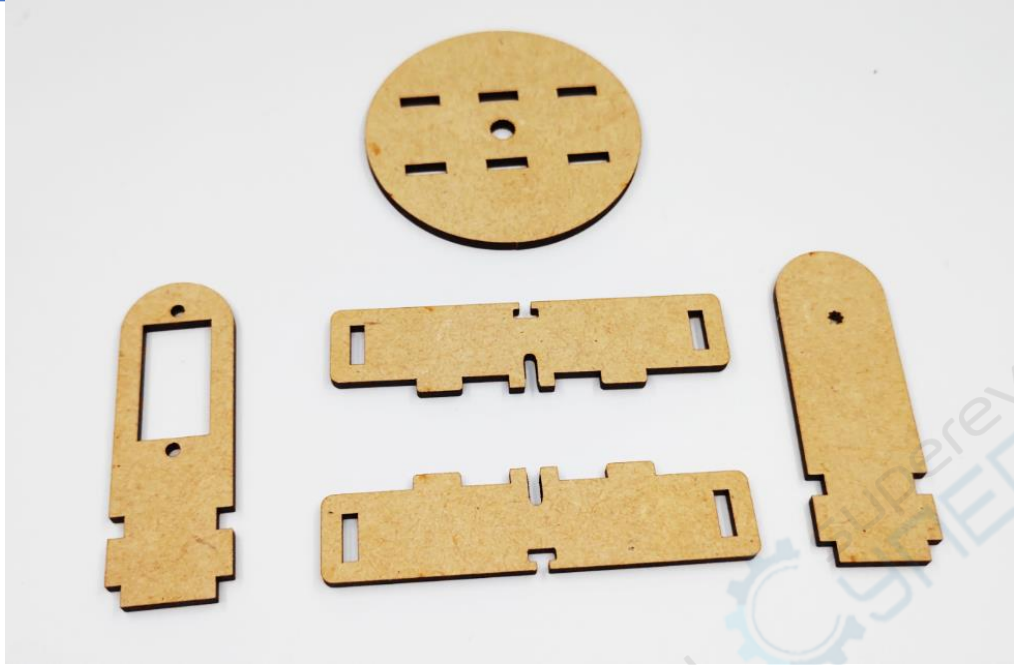

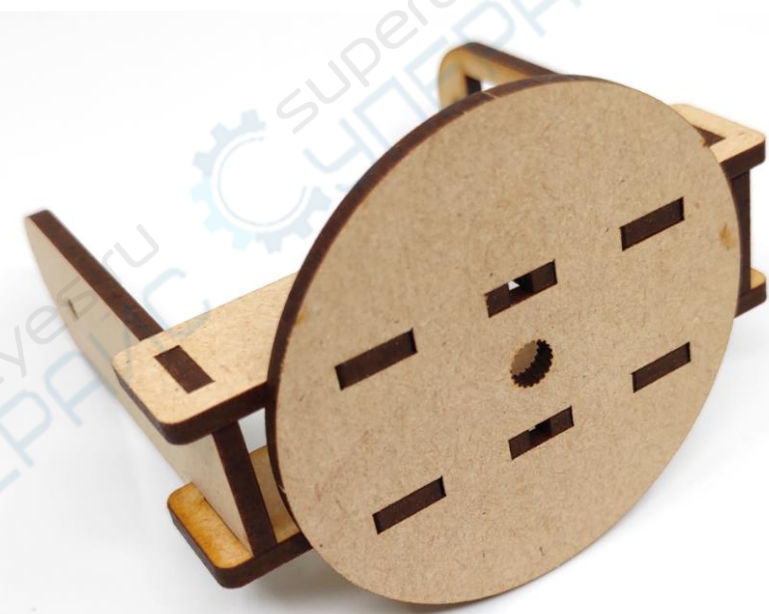

背部用 2 个螺丝固定机架



此位置螺丝无需拧的过紧，点到即可



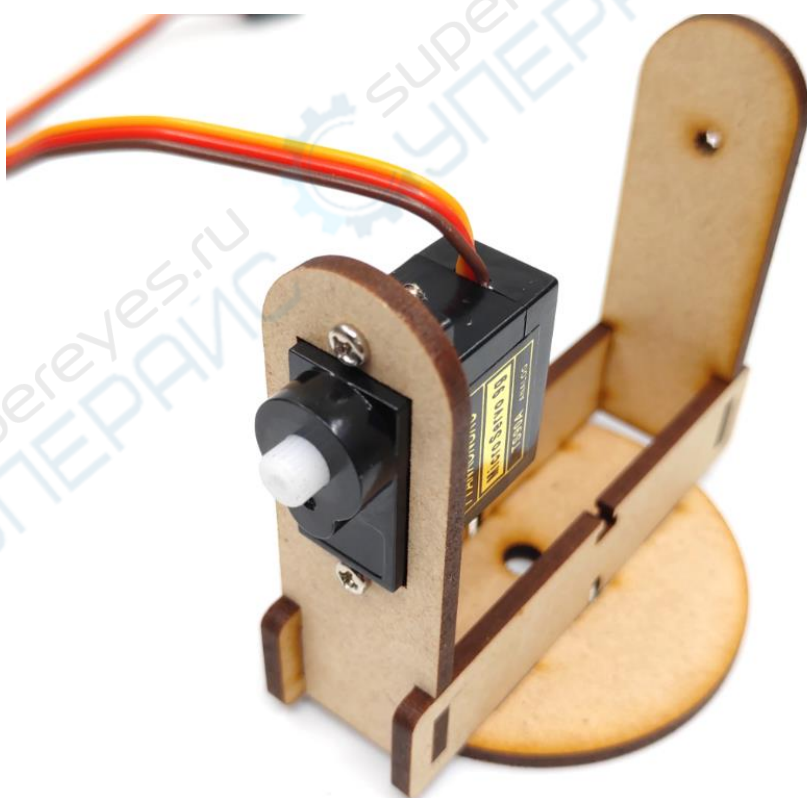

舵机主轴在上，和对面螺丝孔在同一水平线上。



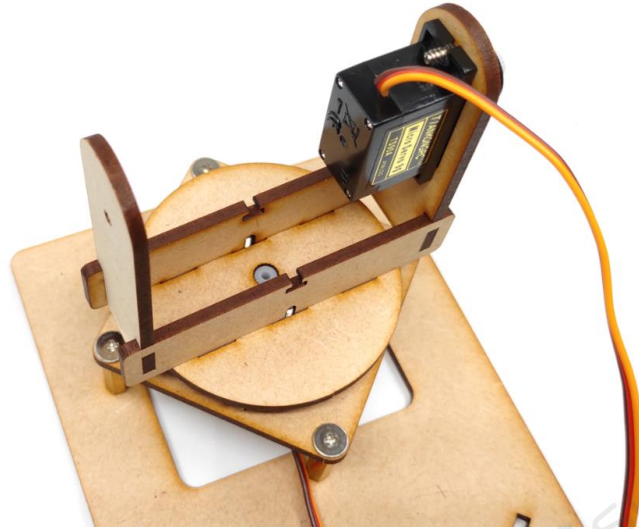

舵机主轴完全插入底座中间孔，此孔略紧。

插底座前，要先确定舵机的有效工作范围再安装底座。（可以先用舵机自带摆臂，手动轻掰，看看舵机的活动范围。不要盲目插好底座后发现，底座只能在侧面或朝后转。）关于舵机的安装位置可以看视频，在第 6 分钟开始讲解。

<https://www.ixigua.com/i6765878731480236547/>

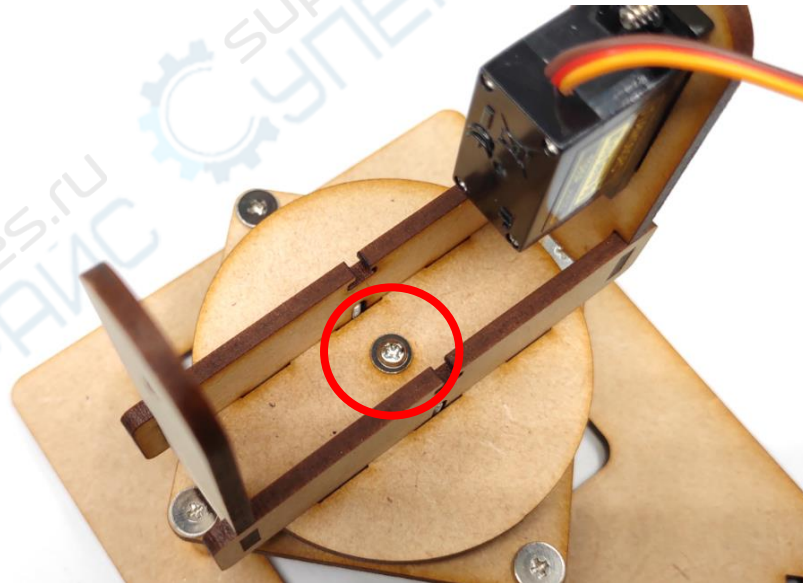

舵机主轴用带垫圈的螺丝固定。

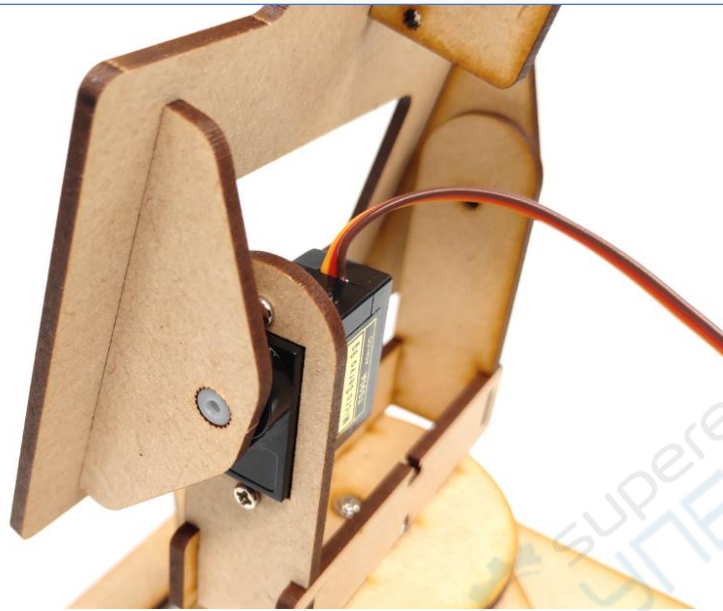

舵机主轴要完全插入侧板的孔中。（同上，要先确定舵机范围）

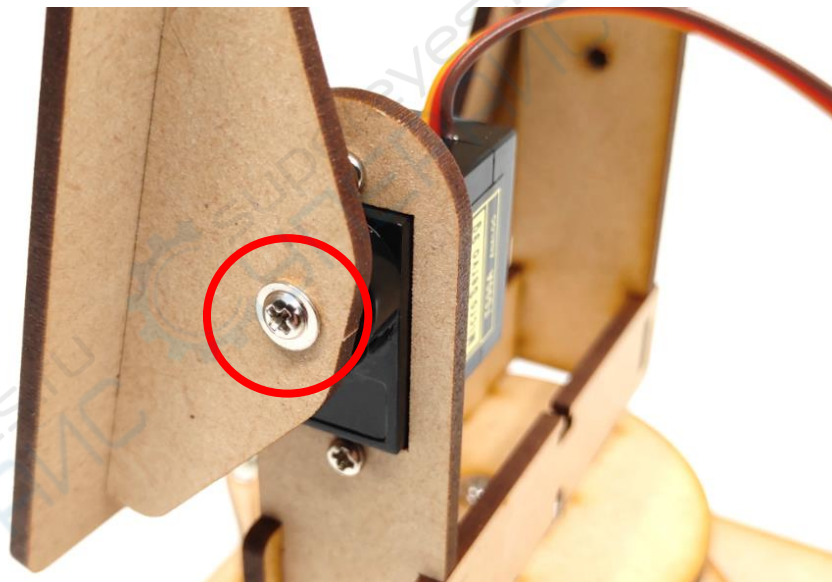

舵机主轴用带垫圈的螺丝固定。



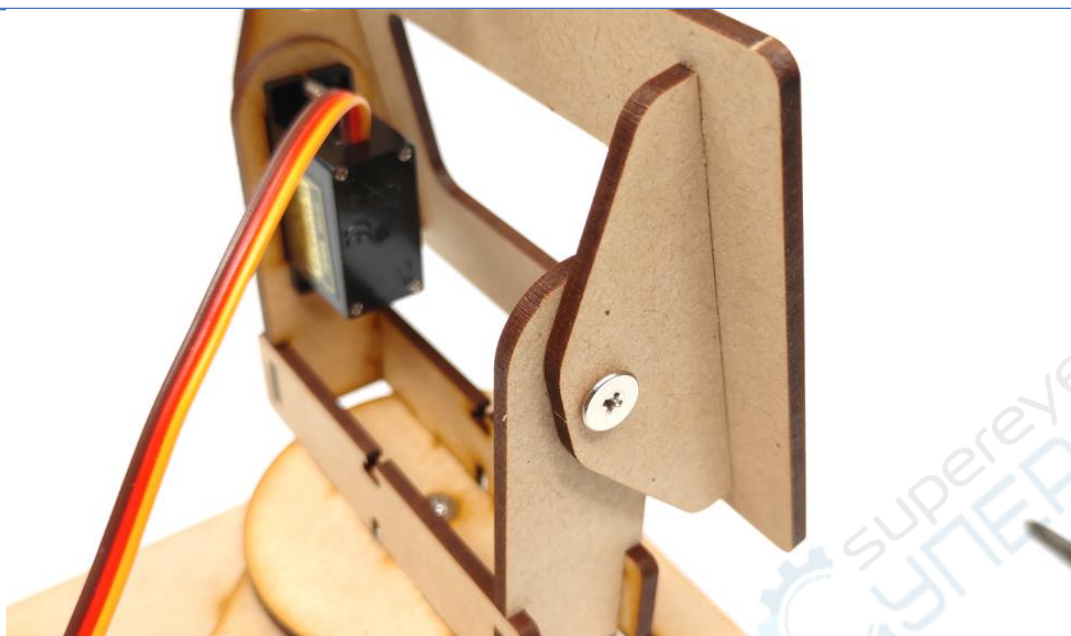

旋转轴螺丝不可拧紧，需留出空间转动

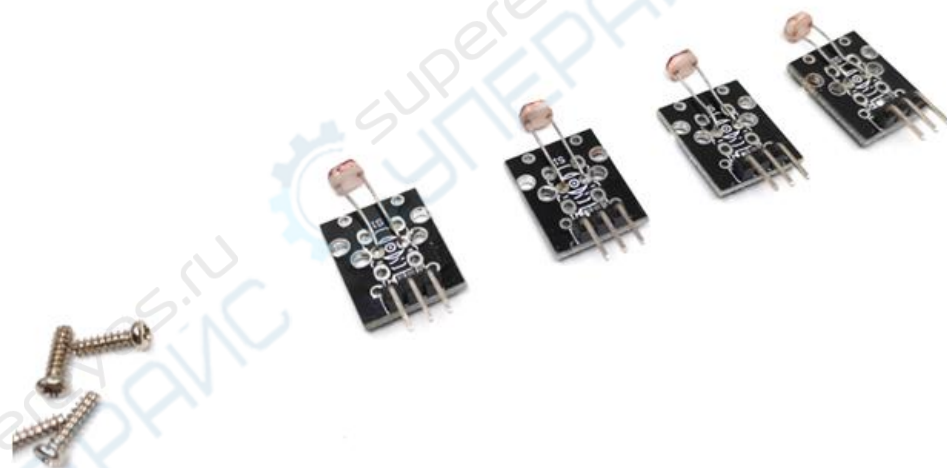

光敏模块用长的粗牙螺丝固定

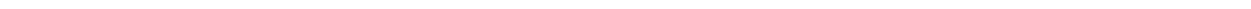

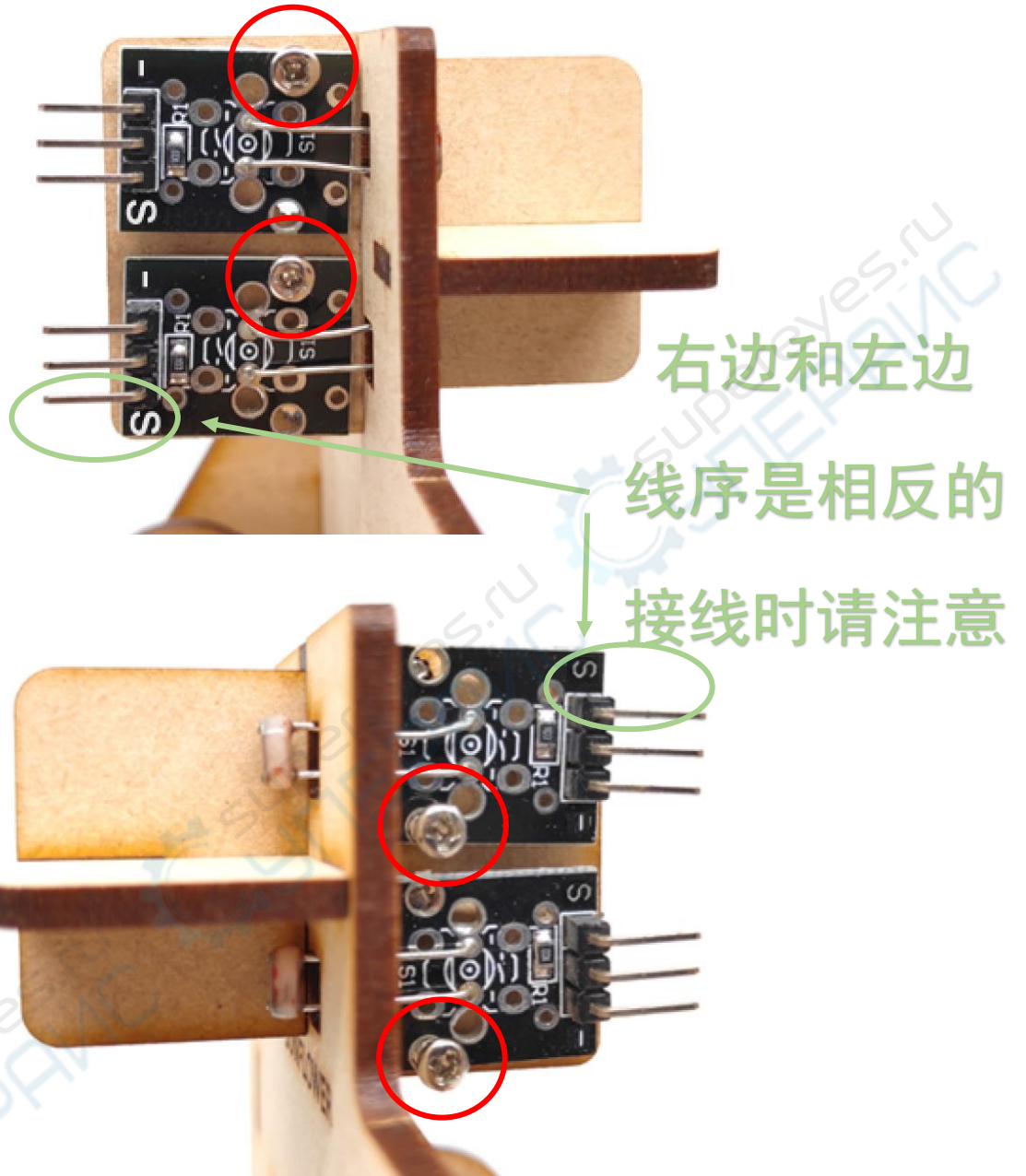

固定模块的螺丝从 2 侧分别拧一个

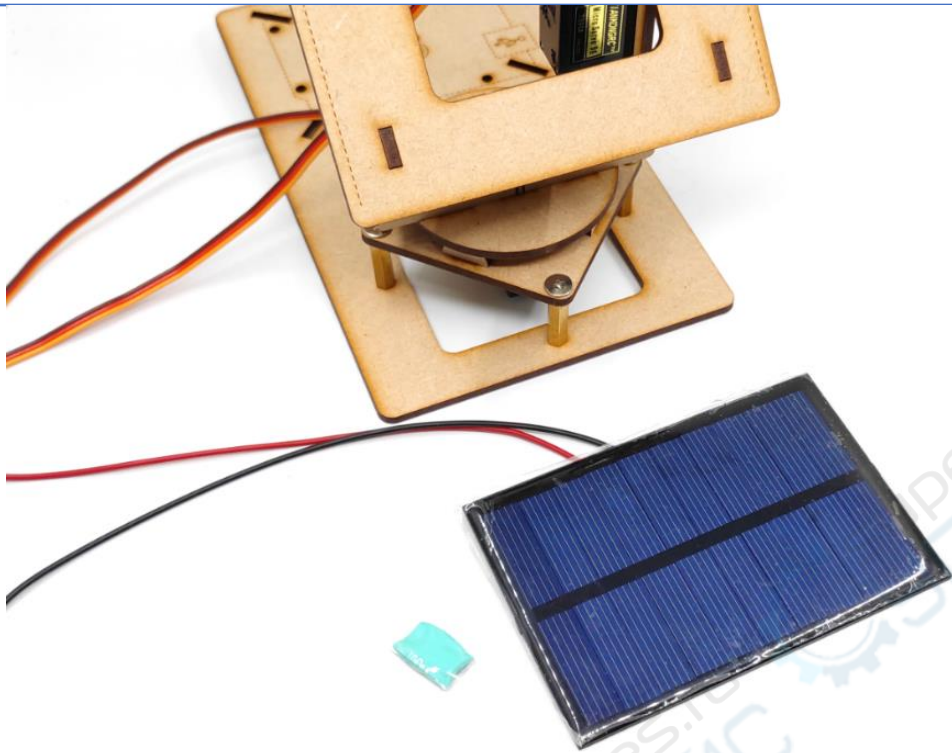

蓝色或白色的“口香糖”是双面胶 不可食用

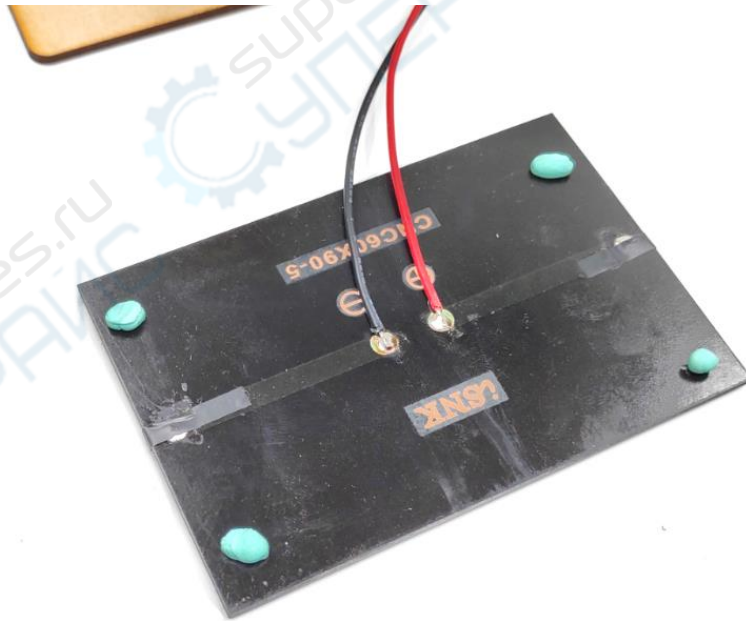

将口香糖捏成小块，粘贴在太阳能板背面



注意太阳能板后背的接线，不要压住



安装 Arduino UNO

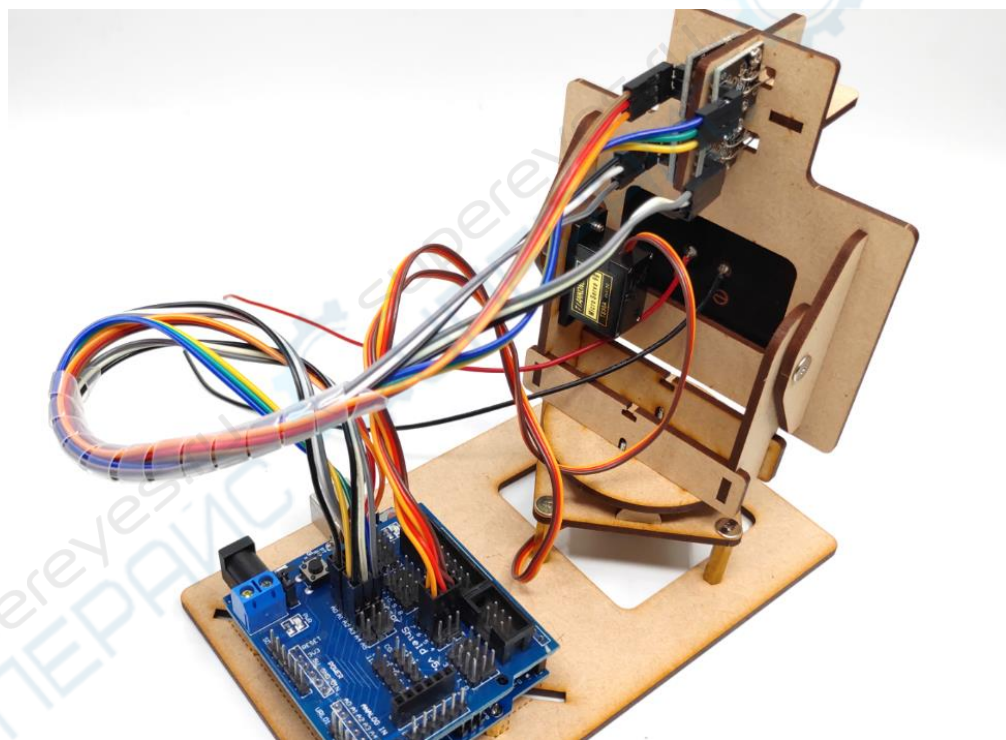
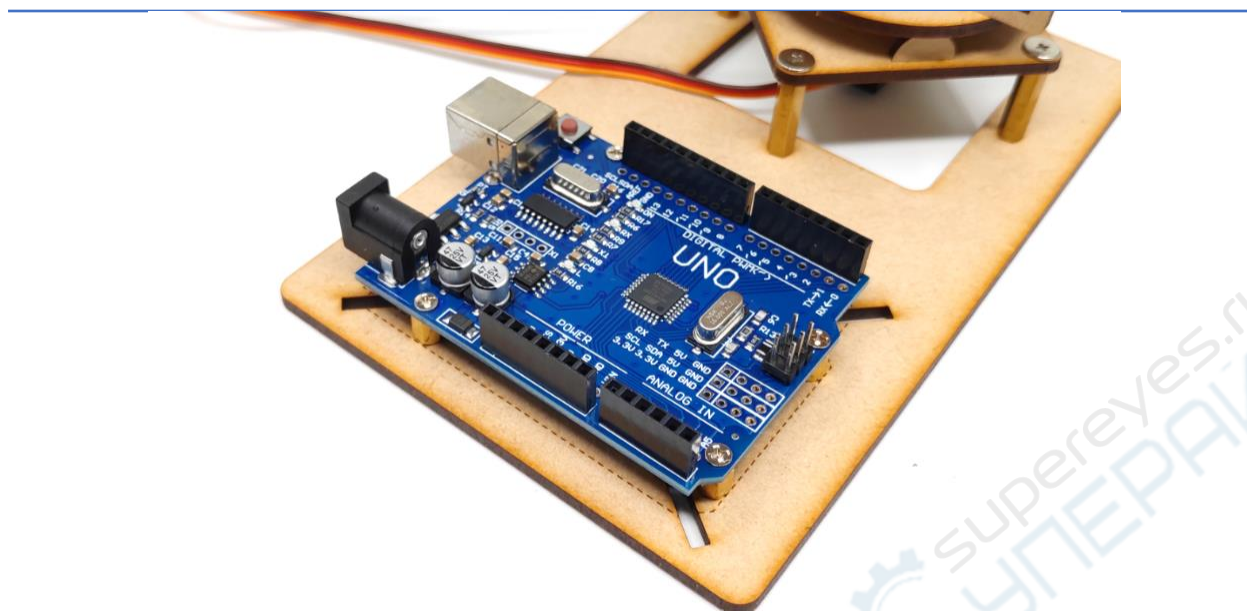

详细接线图请看后续接线介绍，也可以参见程序注释



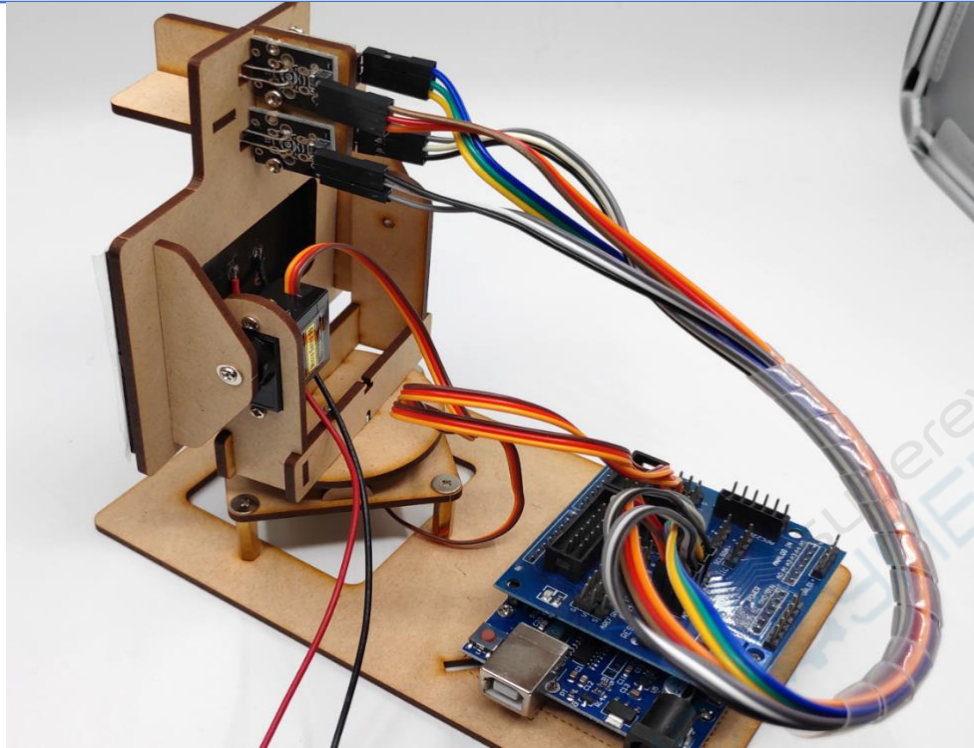

太阳能板可以直连，赠送的电压表。也可以连接其他负载设备。

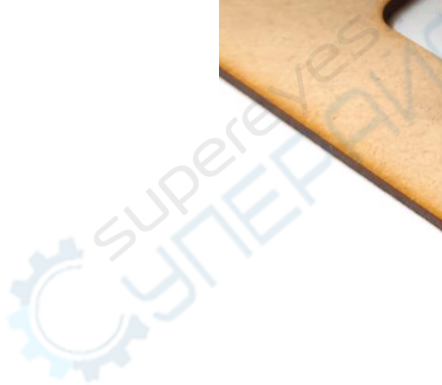

2. 接线

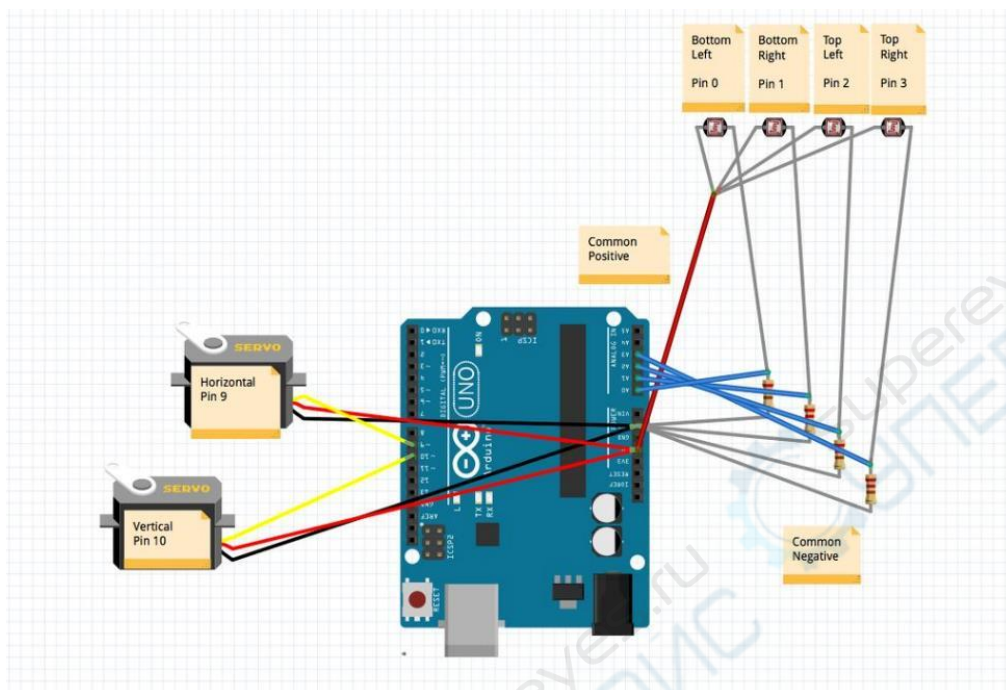

线路原理图，下面有照片图（店售的光敏模块自带电阻无需额外接插电阻）

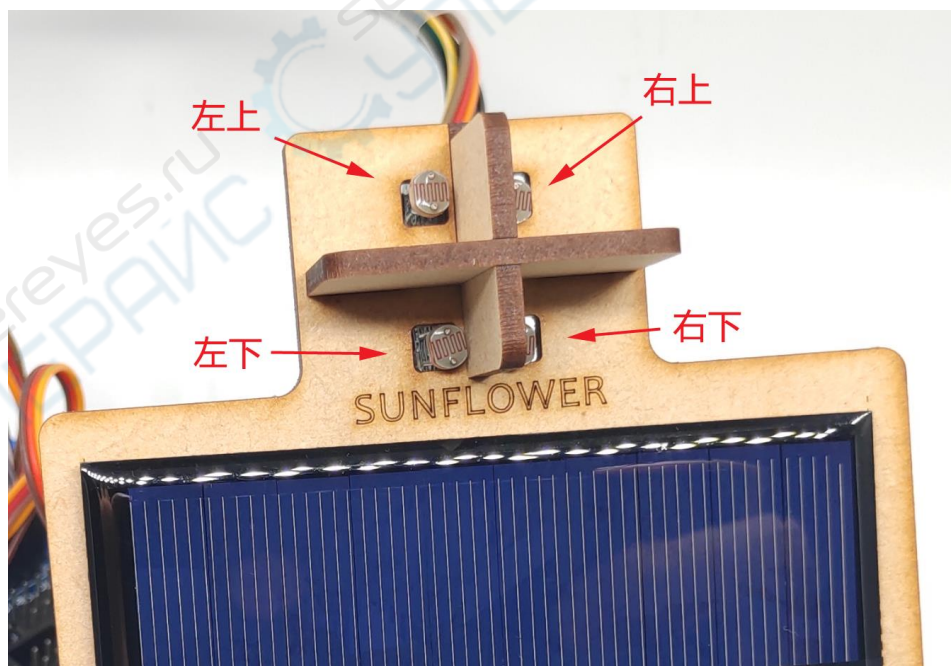

四个光敏模块的位置。（不是从后背看哦！）

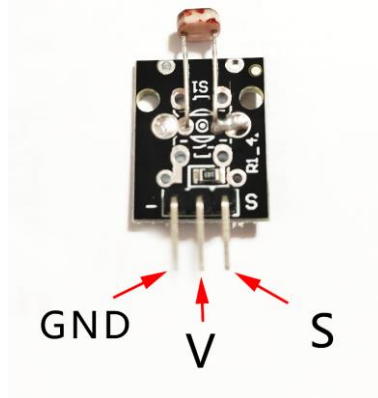

光敏模块的接线顺序是，左侧 GND -，中间 VCC +，右侧 S 信号

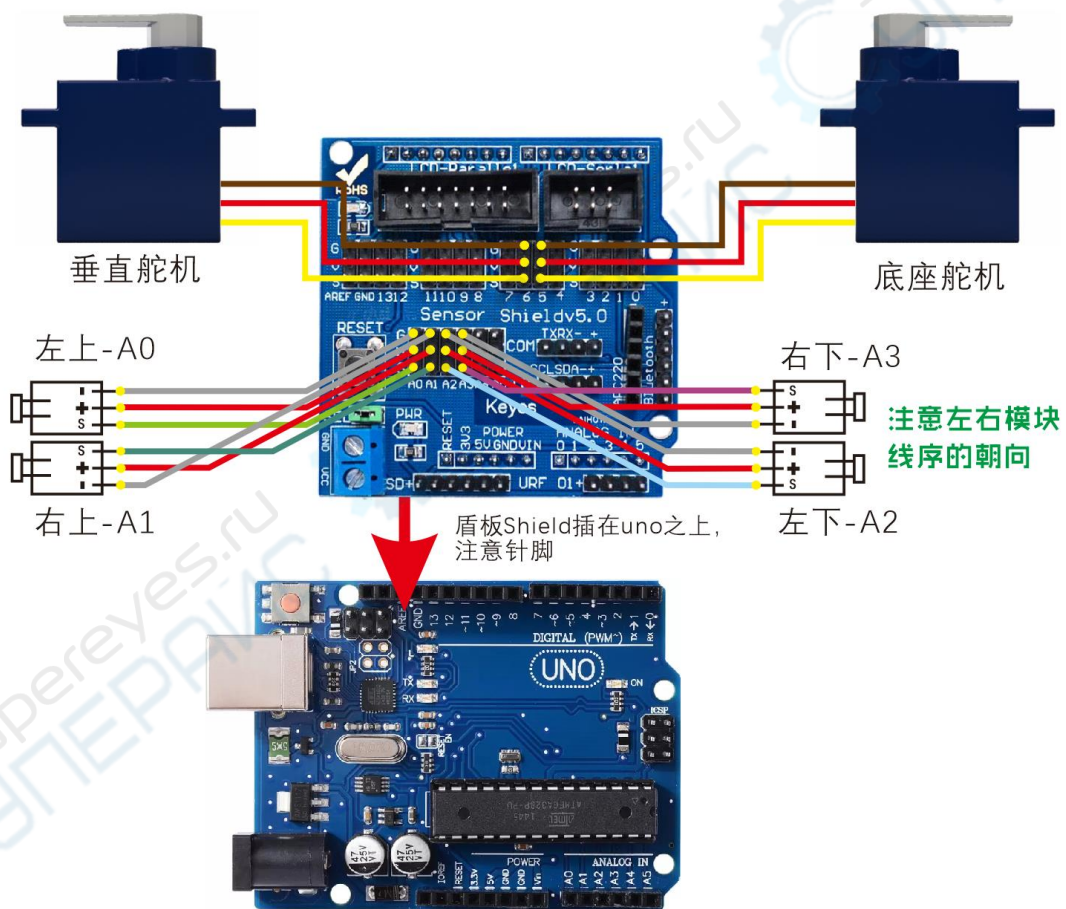

线路的颜色只是为了区分方便，和实际使用线色无关。程序中的接线位置，所有设备的 VCC 是接电源+，GND 接电源 -，有盾板的直接插到对应端口就可以。

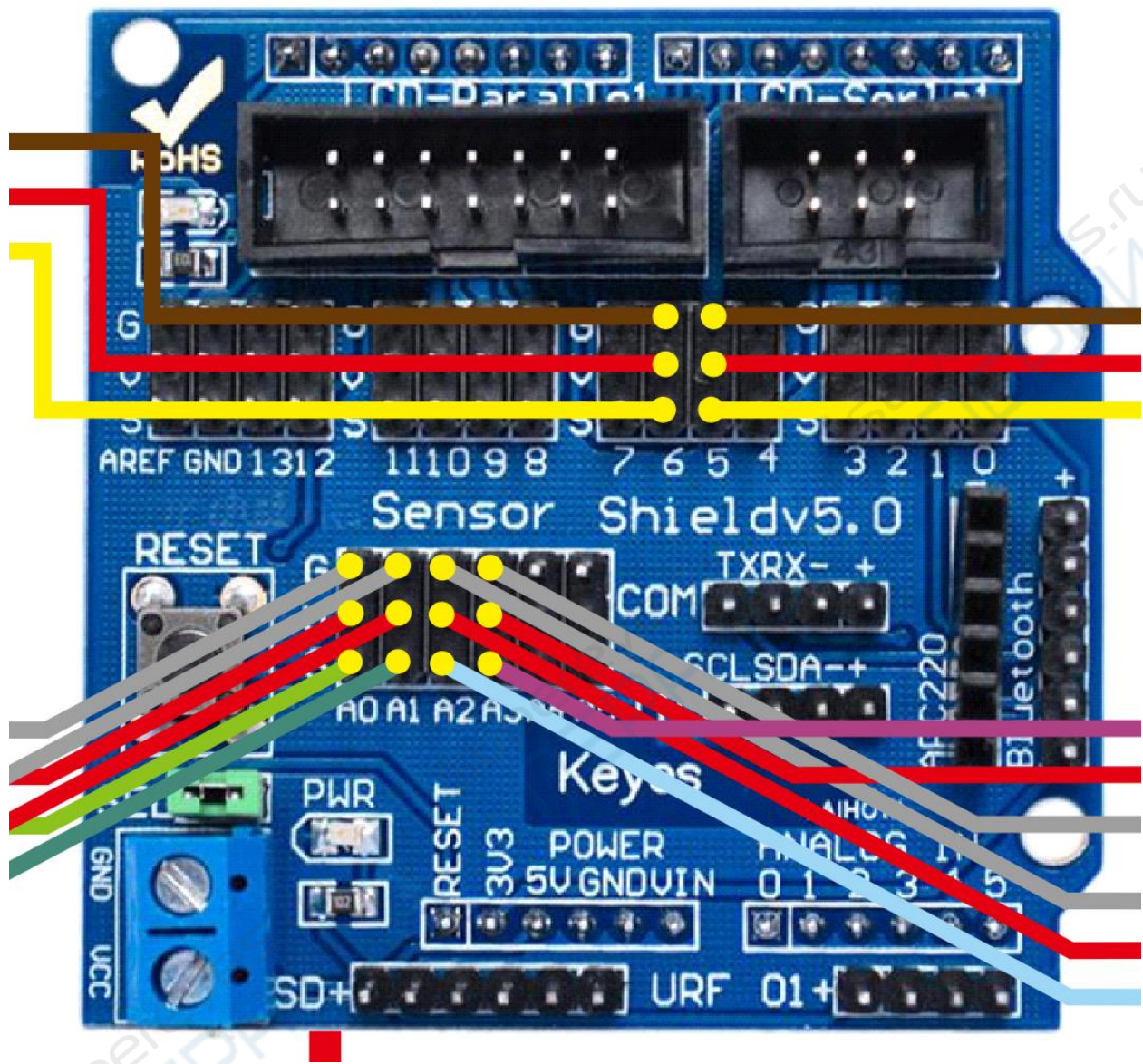

中心位置放大图

- 水平转向舵机 5# 垂直舵机 6# 舵机线棕色 GND，红色 VCC，黄色是信号。
- 4 个感光模块分别接 A0 左上（面朝太阳能板，不是从背后看），A1 右上，A2 左下，A3 右下，每个模块 3 条线分别是 GND，Vcc，S 信号

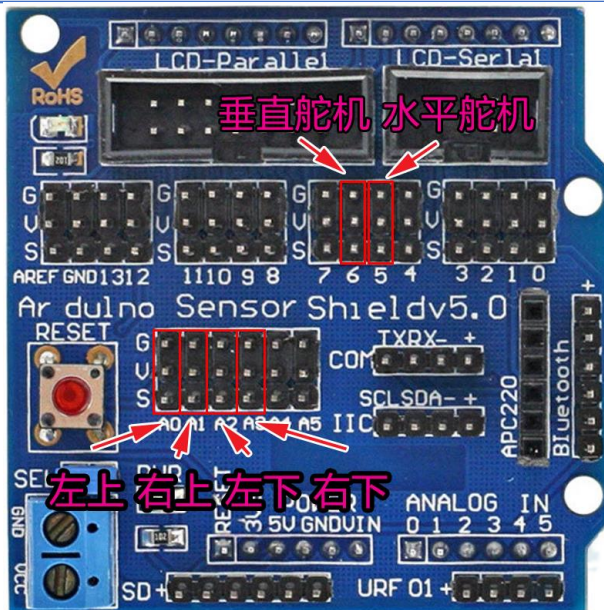

盾板

盾板插于 Arduino UNO 之上，盾板针脚对准 UNO 的排线孔即可。盾板的作用类似接线板，可以方便的接插舵机等设备。盾板针脚的号码和 UNO 的端口一一对应。每个端口都有一个 GND（简写 G）、VCC（V）和 S 信号 的接头。无需面包板接线非常方便。

动手能力强的同学，可以将 4 个模块的 G 和 V 并联在一起，省掉 6 条电线可以减少舵机的压力，运行更流畅。

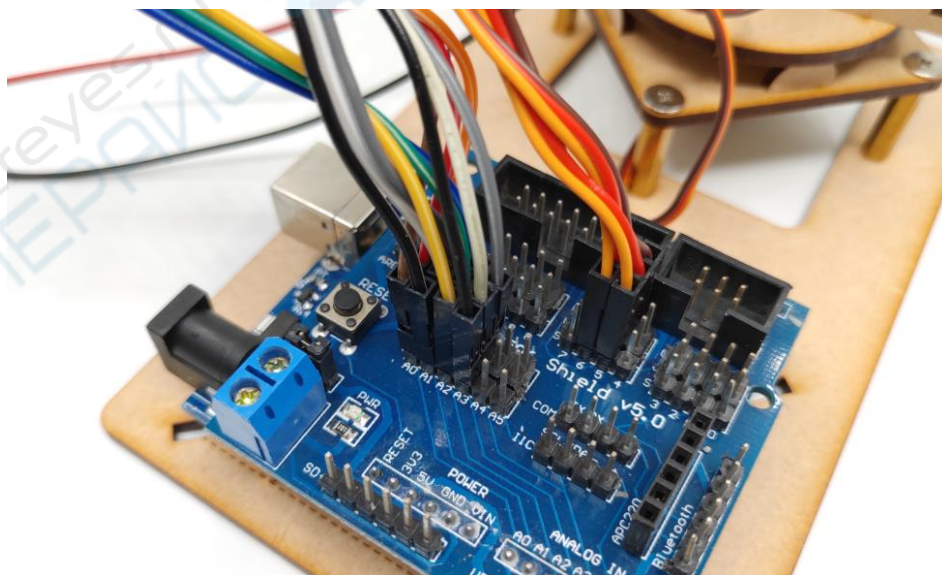

已做好开始准备？

接下来刷程序。如果你还不会刷程序，甚至不会用 Arduino，那么请你先阅读 1 《**Arduino IDE 下载安装教程**》,2 《**Arduino 程序运行教程**》

也可以到西瓜视频观看视频教程：<https://www.ixigua.com/home/2123847662571084/>

程序和资料链接：<https://github.com/shihaipeng03/Sunflower>

或者在线编译器：<https://create.arduino.cc/editor/wjd76/e225717a-ae15-4282-98bd-f9cf09400bee/preview>

常见问题解答

1. 面板总是朝着光弱的方向移动，或是上下不正常，左右正常或反之
答：光敏模块的位置和程序中的位置不一致，或者舵机的方向和预设不一致，只要将程序中舵机的旋转方向修改（180-角度），如果已经是 180-了就去掉 180-，只保留角度数值就可以了。
 2. 接了太阳能板但是无法启动 Arduino
答：示意模型，太阳能板的功率是不够的。只能支持小负载的设备，比如小电机。
 3. 运动方向和光线朝向相反
答：某个舵机的角度参数错了。改成 180 度减去角度就反过来了。（如果已经有 180-了，就去掉 180-）
 4. 开机自测正常，然后就朝向一边不动了
答：左右两侧的光敏模块的接线不能是镜像的，某一侧的接线接反了。右边的光敏模块 3 腿的顺序上 S，中+，下-。左边是上-，下 S。**不是对称的!!! 不要为了好看线都朝同一个方向。**
-

了解更多

欢迎到我们的店铺 <https://somebodys.taobao.com>

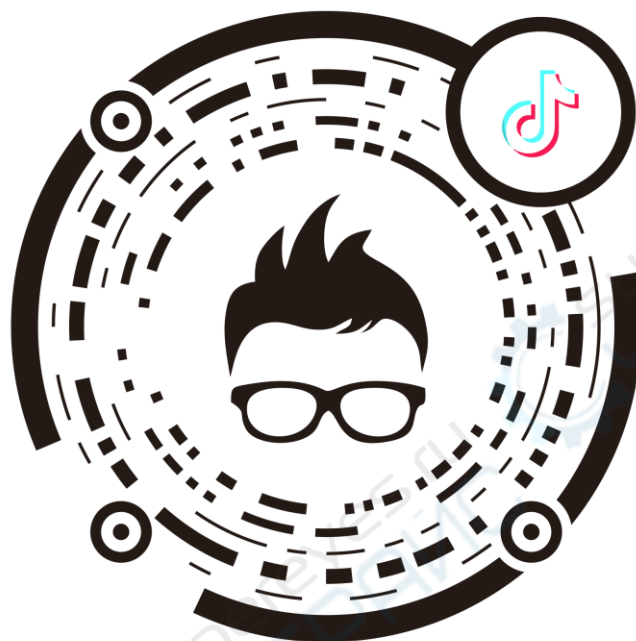

欢迎围观本店抖音账号

