

### Section One Safe Use

To ensure safe use, the meter and manual employ the following symbols:

- ⚠ Warning** identifies conditions and actions that may pose hazard(s) to the user and avoid methods.
- ⚠ Caution** identifies conditions and actions that may damage the meter or the equipment under test and avoid methods.
- ℹ Note** reminds Users of knowledge of symbols for the operation and explanations of the features.

To avoid possible electric shock or any other dangers, please do follow the under-mentioned rules:

- ⚠ Warning**
  - Do not operate the meter around explosive gas, vapor, or dust, which is extreme dangerous.
  - Never apply voltage exceeding 30V between any two terminals and earth ground terminals.
- ⚠ Caution**
  - Do not open the meter's case except for the professional technicians.
  - Use a damp cloth with neutral detergent for cleaning the meter periodically. Do not use abrasives or solvents.
- ℹ Note**
  - To ensure accuracy, preheat for 5 minutes after power-on.
  - Please contact the manufacture or dealers if the Users have higher accuracy requirement.

### Section Two Components and Functions of Meter's Panel

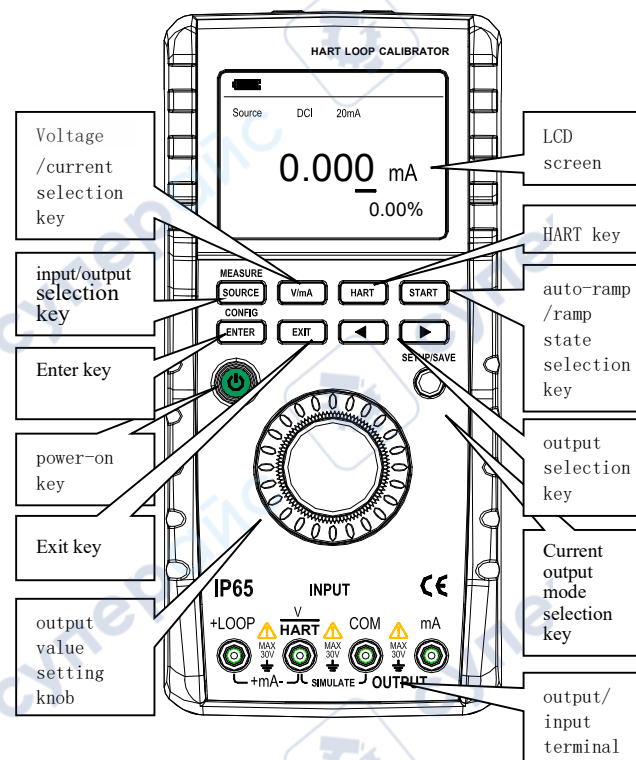

- SOURCE : Shift between output mode and measurement mode
- V/mA : In measurement mode, the meter undertakes shift between voltage function and current function
- HART : In measurement mode, press to enter into HART mode
- START : In current auto-ramp or auto-step mode, press to start or stop output
- ENTER : In measurement or output mode, press to enter into meter setting menu, and repress to enter into the selected option  
In HART mode, press to execute the selected option
- EXIT : Press to exit present interface in the setting menu mode and HART mode
- ◀▶ : Press to select setting position in current output function
- Green round key : Power on/off key, press and hold for 3 seconds to undertake power on or power off operation
- Grey round key : In current output function, press to select output mode
- Rotary key : under setting menu window, switch rotary key to display a setting item, and switch again to change the set parameters after entering into setting option; in current output function, switch rotary key to change setting value

### Section Three setting menu

There are two screens in setting menu, and six items in each and twelve altogether

Specified operations for each setting are shown as follows:

1. Shift the rotary key, select this option;
2. Press ENTER key to enter into setting interface;

3. Switch rotary key to needed parameters;
4. Press the grey round key , the TFT screen shows ‘SAVE’ in the right lower corner to preserve setting;
5. Press EXIT key to exit from setting

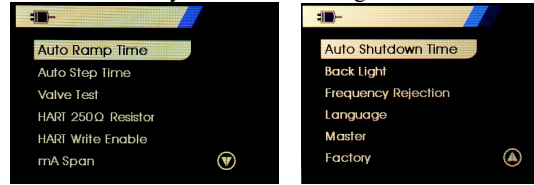

Screen one

Screen two

#### Auto ramp time

The first option in the meter setting menu is used to set the ramp time for full range in current auto-ramp output mode; the value range is from 5 seconds to 60 seconds.

#### Auto step time

The second option in the meter setting menu is used to set the step interval time in current auto-step output mode; the value range is from 5 seconds to 60 seconds.

#### Valve test

The third option in the meter setting menu is used to start or close the valve test function

#### HART resistor

The fourth option in the meter setting menu is used to start or close the HART resistor

#### HART write enable

The fifth option in the meter setting menu is used to start or close the HART write; when in starting mode, LRV and URV operations are allowed while in closing mode, LRV and URV operations are prohibited.

#### Current span

The sixth option in the meter setting menu is used to set the step interval in current auto step mode; when the setting is 0mA to 20mA, 0% of current denotes 0mA and the step value for auto-step is 5mA; when the setting is 4mA to 20mA, 0% of current denotes 4mA and the step value for auto-step is 4mA.

#### Auto-power off time

The seventh option in the meter setting menu is used to set auto-power off time, which is used to set the waiting time for no operation. The time can be set from 0 minutes to 30 minutes and 0 minutes denotes cancelling auto-power off function.

#### Backlight setting

The eighth option in the meter setting menu is used to set backlight of TFT screen, which is used to set high or low light of the backlight.

#### Power frequency setting

The ninth option in the meter setting menu is used to set power frequency, which is used to set power frequency restrain.

#### Language setting

The tenth option in the meter setting menu is used to select the displayed language between Chinese and English.

#### Main HART setting

The eleventh option in the meter setting menu is main HART setting, which is used to select main HART engine; the main HART engine is divided into first main engine and second main engine.

#### Restore to factory default

The twelfth option in the meter setting menu is factory default setting, which is used to choose whether to restore to factory default or not.

### Section Four Maintenance

This section provides some basic maintenance procedures. Repair, calibration, and servicing

not covered in this manual must be performed by qualified personnel. For maintenance procedures not described in this manual, contact a Service Center.

#### General maintenance

- Periodically wipe the case with a damp cloth and detergent; do not use abrasives or solvents.
- Take out the batteries if the meter won't be used for a long time.
- Dirt or moisture in the terminals can affect readings.

Clean the terminals as follows:

- (1) Turn the meter off and remove all test leads.
- (2) Shake out any dirt that may be in terminals.
- (3) Soak a new swab with alcohol. Clean each terminal with the swab.

#### Replacing the batteries

The meter is powered by four LR6 alkaline batteries (AA).

##### ⚠ Warning

To avoid electrical shock or personal injury:

- Remove test leads from the meter before opening the battery door.
- Close and latch the battery door before using the meter.

##### ⚠ Note

- The new and old batteries can not be mixed.
- Make sure the battery's poles are in accordance with the marks illustrated in battery pool when replacing them.
- Take out the batteries if the meter won't be used for a long time.
- Dispose the old batteries in accordance with the local law.

Replace the batteries as follows (See Figure 3-1):

1. Turn the rotary switch to OFF and remove the test leads from the terminals;
2. Take off the support of the meter, rotate 90 degrees of the two plastic screws on the battery cover with a flat head screwdriver respectively, making the groove on the top of the plastic top towards the unlocking logo, and then remove the battery cover.
3. Take off the battery case, replace for new batteries; note for the right polarity; pay attention to the correctness of the polarity when installing the battery.
4. Install the battery cover into the lower part, rotate a reverse 90 degrees of the two plastic screws on the battery cover with a flat head screwdriver respectively, making the groove on the top of the plastic top towards the locking logo.

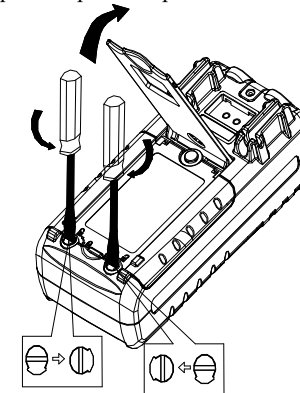

Figure 3-1 replacing batteries

#### Replacing Fuse

##### ⚠ Warning

To avoid personnel injury or damage to the meter, use only the specified fuse. The specification is 100mA/250V fast-melt.

Replace the fuse as follows (Refer to Figure 3-2 if necessary):

1. Remove the test leads from the meter and turn the meter OFF;
2. Take off the protector (the same method as shown in Replacing the Battery);
3. Replace the blown fuse(s);
4. Install the battery cover (the same method as shown in Replacing the Battery);

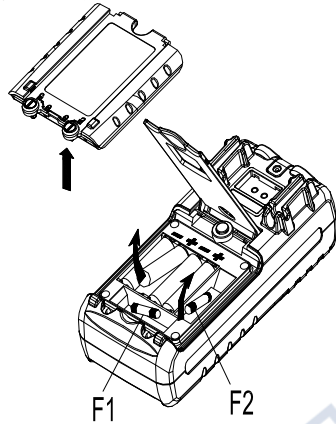

Figure 3-2 replacing fuses

### Section Five Power on/Power off the Meter Turn on/off the meter

Press [power] key for 3 seconds to electrify the meter, and repress [power] key and hold for 3 seconds to cut off the power.

#### ⚠ Note

To ensure correct electrifying operation, please wait for 5 seconds to turn on the meter again after cutting off the power.

### Automatically turn off the power

The default factory value is set as: the meter will automatically turn off if no operation has been made within 10 minutes.

The Users can set by themselves to choose whether using this function or not (See Section Three).

### Section Six Output of the Meter

The meter generates DC current or simulate resistance set by the Users from the corresponding output terminals (OUTPUT).

#### ⚠ Caution

Do not apply any voltage to output terminal; otherwise damage to interior circuit may occur if the voltage is not proper.

### Output Operation Procedure

Function Operation	% Operation	Display	Setting Range
DCI 20mA	20 mA	00.000 mA	00.000~22.000 mA

### Current Output

1. Insert one end of the test leads to the + mA - output jack (OUTPUT) of the Meter and connect the other end with the input of the user's Meter as shown in Figure 5-1:

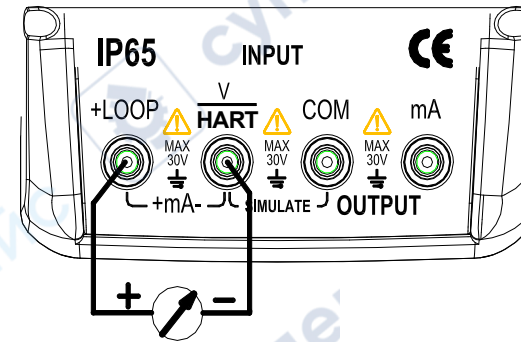

Figure 5-1

2. When the meter enters into working mode, press [SOURCE] key and the symbol Source appears in the upper left corner of the TFT screen. It denotes that the Meter is in output state;
3. Press the key [◀] / [▶] to select the set position of the output;
4. Switch the Rotary key to change the value of the set position. The value can do number carry or decrement automatically.

### 25% Step Current Output

1. Connect to the Meter as shown in Figure 5-1;
2. When the meter enters into working mode, press [SOURCE] key and the symbol Source appears in the upper left corner of the TFT screen. It denotes that the Meter is in output state;
3. Press the [grey round] key and the symbol SET25% appears in the upper left corner of the TFT screen;
4. Switch the Rotary key to change the current output from 0% to 100% in a step of 25%. In which 0% denotes 0 mA or 4mA and 100% denotes 20mA; correspondingly, 25% step value denotes 5mA or 4mA.

### 100% Step Current Output

1. Connect to the meter as shown in Figure 5-1;
2. When the meter enters into working mode, press [SOURCE] key and the symbol Source appears in the upper left corner of the TFT screen. It denotes that the meter is in output state;
3. Press the [grey round] key twice and the symbol SET100% appears in the upper right corner of the TFT screen;
4. Switch the Rotary key to change the current output from 0% to 100% in a step of 100%, in

which 0% denotes 0mA or 4mA and 100% denotes 20mA , depending on the setting of the current length.

#### Auto-ramp Output

1. Connect as shown in Figure 5-1;
2. When the meter enters into working mode, press (SOURCE) key and the symbol Source appears in the upper left corner of the TFT screen. It denotes that the meter is in output state;
3. Press the (grey round) key three times and the symbol  $\infty$  appears in the upper right corner and stop in the lower left corner of the TFT screen, denoting the meter enters into Auto-ramp output mode ;
4. Press the (START) key to change the current output from 0% to 100% in a auto-ramp mode and then return back and repeats, the screen displays start in the left corner. In which 0% denotes 0 mA or 4mA and 100% denotes 20mA , depending on the setting of the current length. The time of full range ramp is the time set in auto-ramp.
5. Repress the (START) key, and the output will pause at the present value, and the symbol STOP shows in the lower left part of the TFT screen, repress the (START) key, and the output will continue execution from the paused point according to the set steps.

#### Auto-step output

1. Connect as shown in Figure 5-1;
2. When the meter enters into working mode, press the (SOURCE) key and the symbol Source appears in the upper left corner of the TFT screen. It denotes that the meter is in output state;
3. Press the (grey round) key four times and the symbol  $\square$  appears in the lower left corner and the symbol STOP in the lower left corner of the TFT screen, denoting the meter enters into Auto-step output mode ;
4. Press the (START) key to change the current output from 0% to 100% in 25% step value and then return back and repeats, the screen displays the symbol START in the lower left corner.  
In which 0% denotes 0mA or 4mA and 100% denotes 20mA , depending on the setting of the current length; and consequently, 25% step value corresponds to 5mA or 4mA.  
The step interval time refers to the set time in the setting menu.
5. Repress the (START) key, and the output value will pause at the present value, and the symbol STOP shows in the lower left part of the TFT screen, and repress the (START) key, the output will continue its execution from the paused point according to the set steps.

#### Simulating Transmitter Output (XMT)

1. Insert one end of the test lead to the 'XMT' jack of the output terminal (OUTPUT) and connect the other end with the input terminal of the user's device as shown in the Figure 5-2:

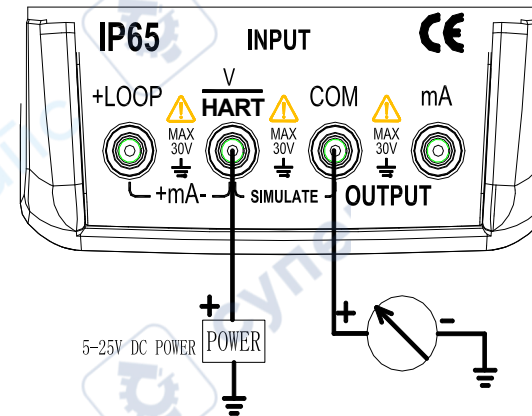

Figure 5-2

2. The key-operation is the same as that of the current output.

#### Note

- Range of power supply: 5 to 25V DC
- Usage: during the operation of the current output, use the external 24VDC power supply in a mode of connecting a transmitter, thus being able to prolong the working life of the battery.

#### Section Seven Meter Measurement

##### Warning

During the operation, never apply more than 30V between any two terminals, or between any terminal and earth ground. Any voltage more than 30V will not only do damage to the Meter, but also lead to possible personal injury.

##### Caution

- During the operation, do not apply a voltage or current exceeding the measuring range to the input terminal, which will cause possible damage to the Meter.
- When connecting to the Meter, the power supply of the device under test should be cut off. Otherwise, any connection with a device without cutting off its power supply will cause possible damage to the Meter.

#### Input Operation Procedure

Function Operation	%Operation	Display	Measurement Range
DCI 30 mA	30 mA	00.000 mA	-4.000~ 33.000mA
DCV 28 V		0.000 V	-2.000~ 28.000 V

### Measuring DC Current

1. Insert one end of the test lead into the mA jack of the input (INPUT) terminal and connect the other end to the output of the user's meter as shown in Figure 5-3:

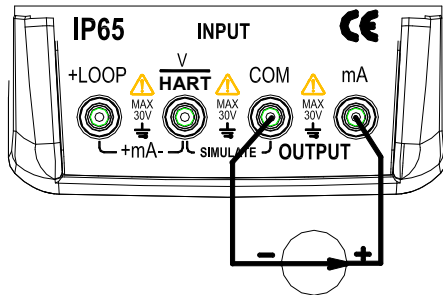

Figure 5-3

2. The default setting is voltage measurement function when the meter enters into working mode.
3. Press the (V/mA) key to shift into current measurement.
4. The meter starts measurement, and the TFT screen displays the measured result.
5. The LCD displays 'OL' if the measured value exceeds the measuring range.

### Measuring DC Voltage

1. Insert one end of the test lead into the V jack of the input (INPUT) terminal and connect the other end to the output of the user's meter as shown in Figure 5-4:
2. The default setting is voltage measurement function when the meter enters into working mode.
3. The meter starts measurement, and the TFT displays the measured result.
4. The LCD displays 'OL' if the measured value exceeds the measuring range.

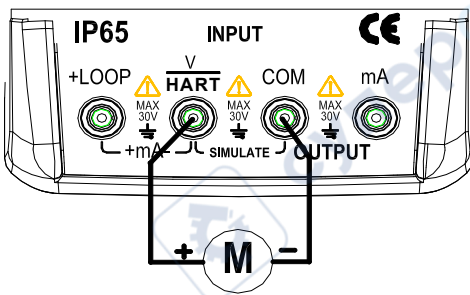

Figure 5-4

### Providing 24V Power Supply for Measuring Loop Current

1. Insert one end of the test lead into the +LOOP and mA jack of the input (INPUT) terminal as shown in Figure 5-5:
2. The default setting is voltage measurement function when the meter enters into working mode.  
The key operation method is the same as shown in DC current.

3. Press the (V/mA) key to shift into current measurement.
4. Press the (grey round) key to start 24V power, and the TFT screen displays 24V in the upper right corner.
5. The meter starts measurement, and the TFT displays the measured result.
6. The LCD displays 'OL' if the measured value exceeds the measuring range.

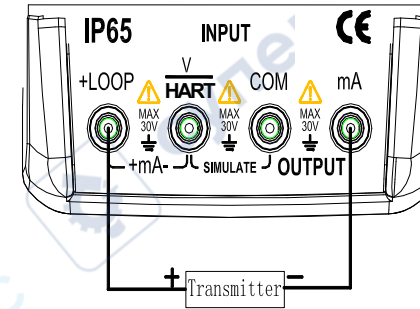

Figure 5-5

### Valve Test

Valve test is used to verify the operation on the valve is right or not. In the test, the output value employs the following step value:

- 3.8mA
- 4.0mA
- 4.2mA
- 8.0mA
- 12.0mA
- 16.0mA
- 19.8mA
- 20.0mA
- 20.2mA

Specified operation is shown as follows:

1. Press ENTER key to enter into setting menu, and change the valve test setting to start.
2. Press Grey Round key to save setting.
2. Press EXIT to exit from setting menu and return back to voltage measurement window.
3. Press SOURCE key to shift to current output function.
4. Shift Rotary Switch, and the meter will output current in the above-mentioned value to test the valve operation is right or not.
5. When finishing the test, press to enter into setting menu to close valve test function.

### Section Eight HART Device Communication Function

The Auto-power-off function will be canceled when using HART communication, and recover when exiting from the HART communication.

The transmitter device supports micro-adjustment function of loop current, while the execution device does not support that function.

If the HART WRITE setting menu is set as closed, the following functions are enabled:

- write in LRV
- Write in URV

Device diagnose  
 4mA micro-adjustment  
 20A micro-adjustment  
 Fixed output  
 PV zero

If the user wants to use the above functions, the HART write setting should be changed to START before entering into HART communication

**HART connection**

**1. mA measurement mode**

In mA measurement mode, the meter is in loop circuit, and the loop power is provided by external source.

If there is 250Ω resistance in the loop circuit, then the HART resistance device is not necessary for the meter

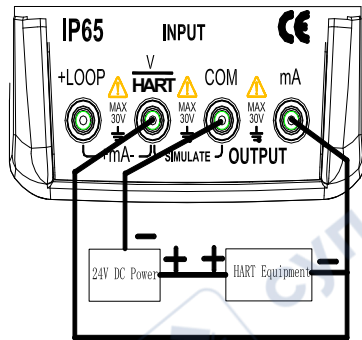

**2. 24V voltage mA measurement mode**

In mA measurement mode of 24V voltage, the meter is in loop circuit, and the loop power is provided by meter.

If there is 250Ω resistance in the loop circuit, then the HART resistance device is not necessary for the meter

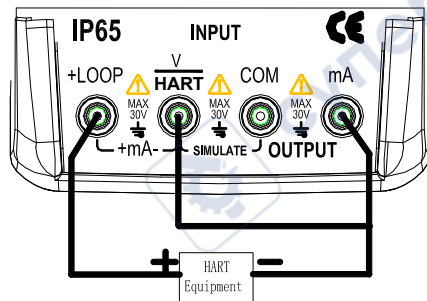

**3. Communication mode**

In communication mode, the meter is in loop circuit, and the loop power is provided by external source.

There should be 250Ω resistance in communication mode.

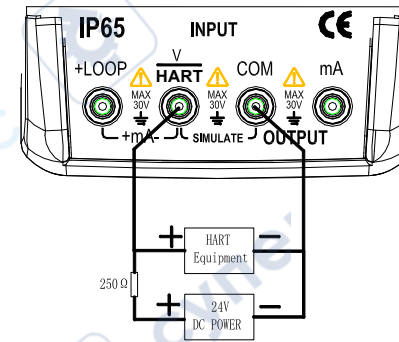

**Communication setting and selection**

When the meter is in measurement state, press HART key to enter into communication menu interface, and the operation mode is set as mA measurement under 24V voltage. The HART communication menu is not available when the meter is in output state.

Before connection of test leads, the modes and 250Ω HART resistance should be connected to the test leads ; if the mode is in communication mode, 250Ω HART resistance is not used, and the 250Ω HART resistance option displays n/a.

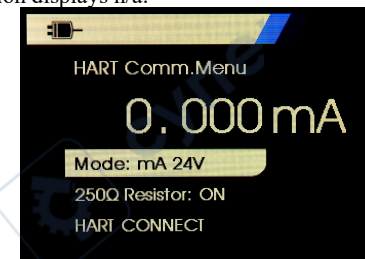

Switch rotary key and select a function from the menu and then press ENTER key to execute this function.

If the measured input signal exceeds the range, the screen displays an error OL or -OL, and does not undertake any operation.

**1. Mode**

Mode function in HART communication menu is used to select working state.

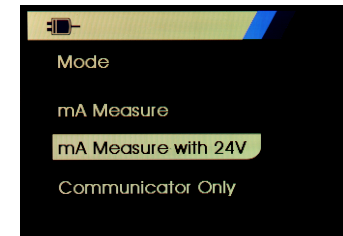

**2. 250ΩHART resistance**

Resistance function is used to start or close 250ΩHART resistance.



### 3. HART connection

HART connection function is used to locate the HART device in a loop circuit; the device must be installed in the loop circuit before using it, and its implementation model goes like this: firstly polling all possible device address and then select one device from the response addressed.

If the meter detects more than one device, it will list a tag, and select right device from the list; if the meter detects only one device, it will select the device acquiescently.

The meter will read all relevant data from the detected device.

#### Polling loop

Polling loop function is used to search whether there is a HART device in the loop circuit. This function will start immediately after execution of HART connection. With the processing of operation, the screen refreshes every second to display the extension of process bar.

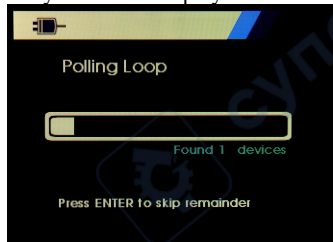

The screen displays the device number detected in loop circuit during the polling process.

If the user knows all the devices have been detected, he can press ENTER key to stop polling in advance. Press EXIT key to stop polling and exit from HART mode.

If no device is detected, then the meter will give a hint.

If the meter detects more than one device, then it will list a tag, and select right device from the list.

If the meter detects only one device, it will jump over the tag selection step.

#### Tag selection

The tag selection screen lists all names of long tags detected in the polling. The name may be displayed in two lines if necessary to show all text.

If long tag is not available or is blank, then short tag is used.

If the short tag name is blank, then the polling address x<empty> is used.

Switch the rotary key to select necessary tag.

#### Data collection

When the meter gets all the configured data in the installed device, the data collection screen will be in display. The process bar extends every second to show the process. Symbol **V** blinks in the upper right corner to show real-time HART connection.

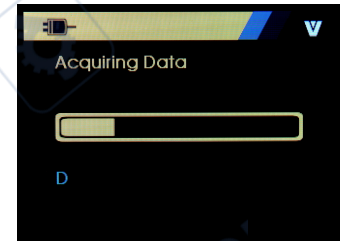

The screen displays all tag names visited.

Press EXIT key to stop data collection and exit from HART mode.

#### Function selection

After the meter finishes the data collection, the screen shows function selection menu. The menu includes five items.

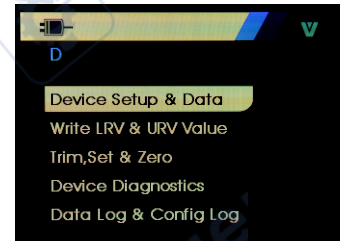

Symbol **V** blinks in the upper right corner to show real-time HART connection.

Switch the rotary key to select necessary operation and press ENTER key to execute the selected operation.

Press EXIT key to exit from HART mode.

#### Device setting and data

The first option in the function menu displays device setting and data function; the device setting and data screen includes eleven sub-screens, switch rotary key to check every sub-screen, and the format of the sub-screen is shown as follows:

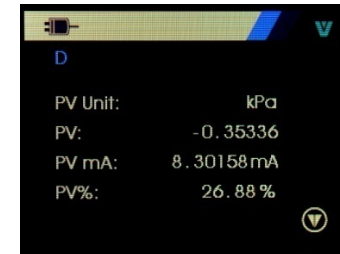

The screen displays all data collected during the collection process. Symbol **V** blinks in the upper right corner, and show real-time HART connection.

Every screen includes six data maximally. If the data is not supported by the HART device, then the mark n/a (not available) displays. The dynamically changed data in the HART device will refreshes in a possible highly frequency in the screen

Switch rotary key to shift between screens. Press EXIT key to exit.

#### Write-in LRV and URV data

The second item in the function selection menu is write-in LRV and URV data function

Symbol  blinks in the upper right corner to show real-time HART connection.

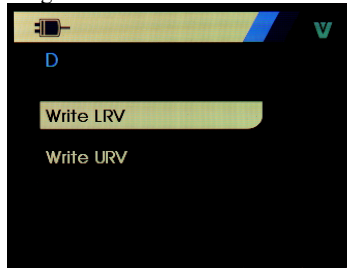

If the HART write-in instruction is not started, this function is not available and the meter will give an unopened hint.

Switch the rotary key to select necessary operation and press ENTER key to execute the selected operation.

Press EXIT key to exit.

#### **Write-in LRV**

Before continuing your operation, this meter will remind you that the loop circuit will be changed to manual operation.

Press ENTER key to continue operation.

The screen shows the present LRV data and unit.

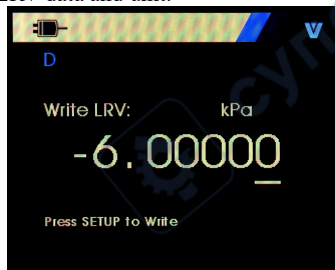

Press EXIT key to exit.

Specified operation to change LRV data:

1. Switch rotary key to adjust LRV data to necessary parameter.
2. Press grey round key to send new data to HART device. If HART device refuses this data, then the screen shows an error.
3. The screen will give a hint that the loop circuit will go back to auto mode after successful sending of the data.
4. Press the EXIT key to exit.

#### **Write-in URV**

Before continuing your operation, this meter will remind you that the loop circuit will be changed to manual operation.

Press ENTER key to continue operation and the screen shows the present URV data and unit.

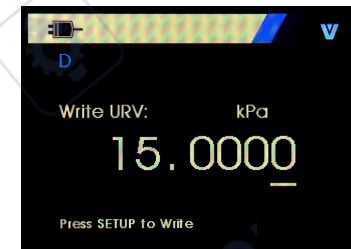

Press EXIT key to exit.

Specified operation to change URV data:

1. Switch rotary key to adjust URV data to necessary parameter.
2. Press grey round key to send new data to HART device. If HART device refuse this data, then the screen shows an error.
3. The screen will give a hint that the loop circuit will go back to auto mode after successful sending of the data.
4. Press the EXIT key to exit.

#### **Micro-adjustment, setting and zero menu**

The third item in the function selection menu is micro-adjustment, setting and zero menu;

Symbol  blinks in the upper right corner to show real-time HART connection.

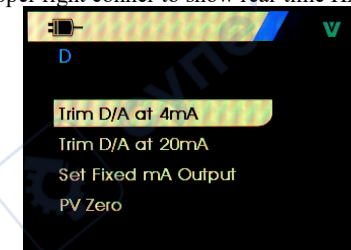

If the HART write-in instruction is not started, this function is not available and the meter will give an unopened hint.

This function is prohibited in communication mode.

Switch the rotary key to select necessary operation and press ENTER key to execute the selected operation.

Press EXIT key to exit.

#### **4mA Micro-adjustment**

If the operation mode is restricted in communication, this function is not available and the meter will give an error hint.

Before continuing your operation, the meter will remind you of changing your circuit back to manual mode.

Press the ENTER key to continue.

When the HART device is changed to fixed output mode, the screen will display an error if the HART device refuses the mode changing command. When the mode is successfully changed, then the screen will display as shown in the following figure:



When the output value is fixed at 4mA, the screen will display the measured value of the meter. And the measured value will refresh every second.

Specified operation for 4mA micro-adjustment:

1. Press ENTER to micro adjust HART device. And then evaluate the result in the mode. If the device refuses the mode changing demand, the screen will display an error.
2. Press EXIT key, the screen will give a hint to change to normal output mode, and then give a hint to change to auto mode. If the device refuses the mode changing demand, the screen will display an error.

#### **20mA Micro-adjustment**

If the operation mode is restricted in communication, this function is not available and the meter will give an error hint.

Before continuing your operation, the meter will remind you of changing your circuit back to manual mode.

Press the ENTER key to continue.

When the HART device is changed to fixed output mode, the screen will display an error if the HART device refuses the mode changing command. When the mode is successfully changed, then the screen will display as shown in the following figure:



When the output value is fixed at 20mA, the screen will display the measured value of the meter. And the measured value will refresh every second.

Specified operation for **20mA Micro-adjustment**:

1. Press ENTER to micro adjust HART device. And then evaluate the result in the mode. If the device refuses the mode changing demand, the screen will display an error.
2. Press EXIT key, the screen will give a hint to change to normal output mode, and then give a hint to change to auto mode. If the device refuses the mode changing demand, the screen will display an error.

#### **Set fixed mA output**

If the operation mode is restricted in communication, this function is not available and the meter will give an error hint.

Before continuing your operation, the meter will remind you of changing your circuit back to manual mode.

Press the ENTER key to continue.

The HART device is changed to fixed output mode, the screen will display an error if the HART device refuses the mode changing command. When the mode is successfully changed, then the screen will display as shown in the following figure:

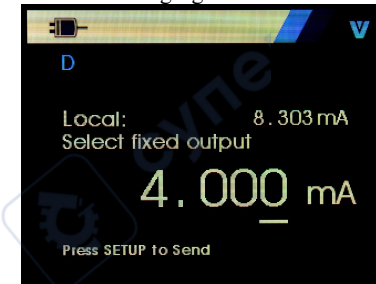

This mode is used to set fixed output, and monitor the result by the measured value of the meter. And the measured value will refresh every second.

The setting range of the value is 3.0 mA ~ 21.0mA.

Specified operation for fixed mA output:

1. Switch rotary key, adjust the data to the necessary parameters.
2. Press the grey round key to send the new value to the HART device, and keep in the screen display. The screen will display an error if the HART device refuses the mode changing command.
3. Press EXIT key, the screen will give a hint to change to normal output mode, and then give a hint to change to auto mode. If the device refuses the mode changing demand, the screen will display an error.

#### **PV zero**

If the operation mode is restricted in communication, this function is not available and the meter will give an error hint.

Before continuing your operation, the meter will remind you of changing your circuit back to manual mode.

Press the ENTER key to continue. And the screen will display as shown in the following figure:

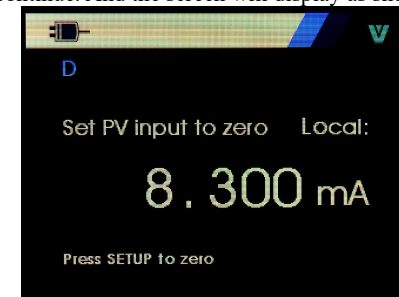

Specified operation for PV zero:

1. Press the grey key to zero the PV input value, and keep in the screen display. The screen will display an error if the HART device refuses the mode changing command.

2. Press EXIT key, the screen will give a hint to save PV input value, and then return back to auto mode.

### **Device diagnose**

The fourth item in the function selection menu is device diagnose;

Symbol **V** blinks in the upper right corner to show real-time HART connection.

If the HART write-in instruction is not started, this function is not available and the meter will give an unopened hint.

Before continuing your operation, the meter will remind you of changing your circuit back to manual mode.

Press the ENTER key to continue. And the screen will display as shown in the following figure:

Repress ENTER to start self-diagnose.

After the self-diagnose finishes, the screen will report right or wrong; the wrong screen includes four sub-screens, and switch the rotary key to check the contents in every screen. The sub screen is shown as follows:

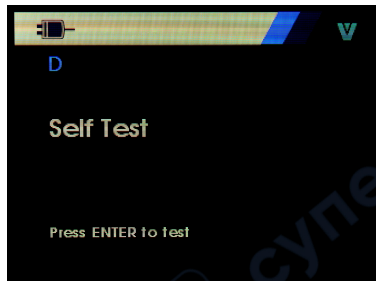

Press EXIT key, the screen will give a hint to change to auto mode, and then repress the EXIT key to exit from this function.

### **Data logging and configuration logging**

The fifth item in the function selection menu is data logging and configuration logging;

The configuration logging and data logging are only available when connected in HART device.

Use the rotary switch to select configuration logging or data logging.

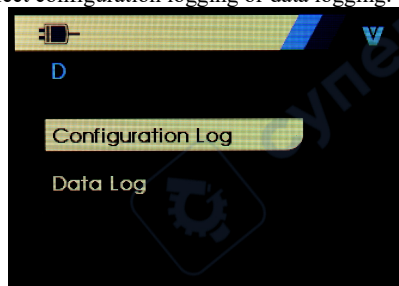

### **Configuration logging**

The meter can store configuration data for twenty tags maximally for callout. And the stored configured data and device data shown in the screens are the same.

The initial configuration logging screen spans among several screens, and will display all the stored tag logging. If there is unused storage location, the tag name part will display <empty>. Shown as figure:

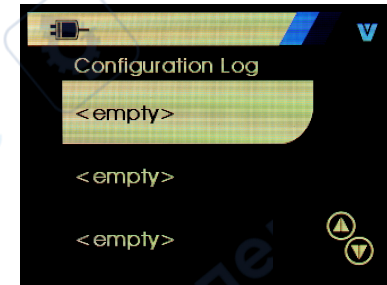

When selecting a storage location, you can save data or call data. Besides, you can delete data or send data to USB terminal or upload the data to your PC

Switch the rotary key to select the right storage location, press ENTER key to enter into the storage location submenu, as shown in figure:

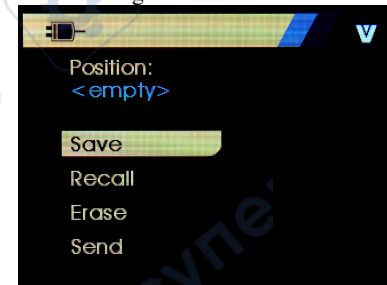

The number and content of the storage location are shown in the top. If there is unused storage location, the tag name part will display <empty>. Shown as figure:

Switch the rotary key to select the necessary function, press ENTER key to execute.

Saving operation:

If the storage location is null value, then the meter will save the device configuration data to the location.

If the storage location is in use, please confirm whether to replace the existing data to the current tab data before you save the data to the storage location.

Reading operation:

If the storage location is null value, the meter will send an error message.

If the storage location is in use, then the meter will display data in the same sequence as shown in the "device data" screen.

Clearing operation:

If the storage location is null value, the meter will send an error message.

If the storage location is in use, then the meter will confirm whether to conduct permanent deletion before deleting the data.

Sending operation:

If the storage location is null value, the meter will send an error message.

### **Data logging**

This function is used for saving process data in a single tag in order to send to a PC with software. Data can be recorded in many conversations, but all conversation should come from the same HART device determined by the long tag name. You can select a different logging interval for

every conversation. Every sample data includes the measured value, installed mA current and all four process variables.

1200 records are available. And every sample data uses one record. Every conversation uses two records for top data, for which the top data is common used by all data sample. The number for conversation is 1 to 99.

The total number for recorded data is twice of the number difference by 1200 subtracting the conversation numbers of start and stop. As shown in following figure:

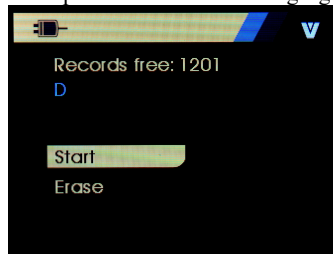

The number of free records is showed in the first row. If the data has been recorded, the tag number will be displayed below.

Switch the rotary key to the needed function, and then press ENTER to execute.

Starting operation:

If there are no free records or free conversations, or the current HART device does not match with the recorded HART device, then the meter shows an error message. Otherwise the meter goes into the interval option showed in the Figure.

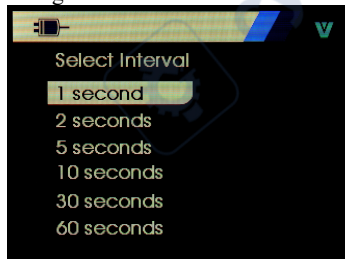

Switch the rotary key to the necessary interval logging interval. Press ENTER key and record according to the intervals. When the meter is recording, the screen shows the following figure to monitoring the process.

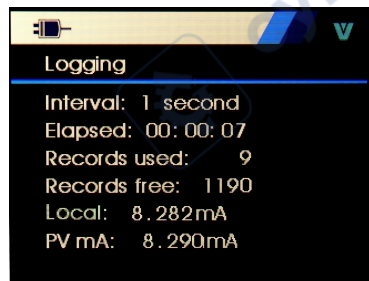

All the data item displayed are:

Top row logging is recording or has stopped. When the recorder is full, or before the meter is powered off due to the battery reaches the low voltage limits for auto power-off, the recording will stop automatically.

Interval time refers to the data selected by the previous option

Used time refers to the exhausted time when the logging starts, and data will refresh for every new sample.

Used record refers to the total record number of all conversation until present.

Free record refers to the total number for unused record. and will refresh for every new sample.

Local refers to present measured value and will refresh in frequency as high as possible.

PV mA refers to the last measured value by HART device and will refresh in frequency as high as possible.

Clearing operation;

If there is no record data, the meter displays an error message.

Otherwise the meter goes into the interval option showed in the Figure.

**Section Eight Performance Index**

Output Performance Index (applicable to temperature range from 18°C to 28°C, within one year after calibration)

Output	Range	Output Range	Resolution	Accuracy	Remark
DCA	20mA	0.000~22.000mA	0.001mA	±0.01%Set value ±0.015%range	Max. load 1KΩat 20mA.
Simu-transmitter (absorption current)	-20mA	0.000~-22.000mA	0.001mA	±0.01% Set value ±0.015% range	Max. load 1KΩat 20mA. Note: power supply range: 5~25VDC
Loop Power Supply	24V			±10%	Max. output current up to 25mA.

Input Performance Index(applicable to temperature range from 18°C to 28°C, within one year after calibration)

Input	Range	Output Range	Resolution	Accuracy	Remark
Voltage	28V	-2.000~28.000V	1mV	±0.01% reading ± 0.01% range	Input resistance about 1MΩ
Current	30mA	-4.000~33.000mA	0.001mA	±0.01% reading ± 0.01% range	Input resistance about 20Ω
Loop Current	20mA	0.000~22.000mA	0.001mA	±0.01% reading ± 0.01% range	providing 24V loop power

**General Specifications**

- Power supply : four 1.5V alkaline batteries(LR6)
- Battery life : about 360mA /5V under the condition of 20mA with 1kΩ load
- Max. permitted voltage : 30V(between any two terminals or between any terminal and earth ground)
- Operating temperature : 0°C~50°C

- Operating relative humidity :  $\leq 80\%RH$
- Storage temperature :  $\leq -20^{\circ}C \sim 60^{\circ}C$
- Relative humidity for storage :  $\leq 90\%RH$
- Temperature co-efficiency :  $0.1 \times \text{Basic accuracy} / ^{\circ}C$  (Temperature  $< 18^{\circ}C$  or  $> 28^{\circ}C$ )
- Protection level : IP65 (Dust, Water spray)
- Display : 3.2 inch TFT color display
- Size : 206 (L)  $\times$  97 (W)  $\times$  60 (D) mm
- Weight : 600g
- Safety : EN61010-1: 2001
- Accessories : The test pen (H000000-00)  
Industrial test lead (H000002-00)  
Crocodile clip (H010000-00)  
Quick guide\_English (E100073-00)  
Product qualification certificate\_English (E300018-00)  
Product user manual \_ English (E400022-00)  
Insurance tube (D610000-00)  
5alkaline battery (D620002-00)
- Option : PC infrared communications accessories package (Z070102-0000-00)  
Linear power adapter(DC5V) (P070003-00)  
Hook type tester (H000004-00)

***Section Nine Notice of the Manual***

- The present operation instruction is subject to change without notice;
- The content of the operation instruction is regarded as correct. Whenever any user finds its errors, omission, etc., he or she is requested to contact the manufacturer;
- The present manufacturer is not liable for any accident and hazard arising from the customer misuse or inadvertent operation;
- The functions described in this operation instruction should not be used as grounds to apply this product to a particular purpose.