

# ZC100/300 Series



## User Guide



**ZEBRA**

## Copyright

© 2017 ZIH Corp. and/or its affiliates. All rights reserved. ZEBRA and the stylized Zebra head are trademarks of ZIH Corp., registered in many jurisdictions worldwide. All other trademarks are the property of their respective owners.

**COPYRIGHTS & TRADEMARKS:** For complete copyright and trademark information, go to: [www.zebra.com/copyright](http://www.zebra.com/copyright)

**WARRANTY:** For complete warranty information, go to: [www.zebra.com/warranty](http://www.zebra.com/warranty)

**END USER LICENSE AGREEMENT:** For complete EULA information, go to: [www.zebra.com/eula](http://www.zebra.com/eula)

## Terms of Use

**Proprietary Statement** This manual contains proprietary information of Zebra Technologies Corporation and its subsidiaries (“Zebra Technologies”). It is intended solely for the information and use of parties operating and maintaining the equipment described herein. Such proprietary information may not be used, reproduced, or disclosed to any other parties for any other purpose without the express, written permission of Zebra Technologies.

**Product Improvements** Continuous improvement of products is a policy of Zebra Technologies. All specifications and designs are subject to change without notice.

**Liability Disclaimer** Zebra Technologies takes steps to ensure that its published Engineering specifications and manuals are correct; however, errors do occur. Zebra Technologies reserves the right to correct any such errors and disclaims liability resulting therefrom.

**Limitation of Liability** In no event shall Zebra Technologies or anyone else involved in the creation, production, or delivery of the accompanying product (including hardware and software) be liable for any damages whatsoever (including, without limitation, consequential damages including loss of business profits, business interruption, or loss of business information) arising out of the use of, the results of use of, or inability to use such product, even if Zebra Technologies has been advised of the possibility of such damages. Some jurisdictions do not allow the exclusion or limitation of incidental or consequential damages, so the above limitation or exclusion may not apply to you.

# Contents

<b>Introduction</b> .....	<b>1</b>
About This Manual .....	1
About the Printer .....	1
Features, Controls, and Indicators .....	2
LCD Menu Navigation .....	4
Printer Ready Screen .....	4
Printer Soft Keys .....	4
Help Menu .....	5
Info menu .....	6
Tools Menu .....	6
Connection Status .....	7
Ethernet Connection .....	7
Bluetooth Connection .....	7
Wi-Fi Connection .....	7
<b>Setup</b> .....	<b>9</b>
Unpacking .....	9
Connecting Power .....	9
Connecting USB .....	10
Connecting Ethernet .....	10
Loading Ribbon .....	11
Loading Cards .....	11
Printing a Sample Card .....	12
Printing a Test Card .....	12
Installing the Driver .....	12
Manual Feed .....	13
Retrieving a Rejected Card .....	13
<b>Options</b> .....	<b>15</b>
Mag Encoder .....	15
Magnetic Encoding Type .....	15

## Contents

Smart Card Encoder . . . . .	16
Contact Smart Cards . . . . .	16
Contactless Smart Cards . . . . .	16
Contact Station . . . . .	16
Double-sided Printing . . . . .	17
Wi-Fi . . . . .	17
Description . . . . .	17
<b>Cleaning . . . . .</b>	<b>19</b>
Cleaning the Printer . . . . .	19
From the LCD Menu . . . . .	19
From the Driver Software . . . . .	20
Cleaning the Printhead . . . . .	21
Cleaning the Mag Encoder . . . . .	21
Cleaning Supplies . . . . .	21
<b>Troubleshooting . . . . .</b>	<b>23</b>
LCD Warnings and Errors . . . . .	23
LED Warnings and Errors . . . . .	24
Clearing a Card Jam . . . . .	24
Identifying Job Quality Issues . . . . .	25
Print Quality Issues . . . . .	25
Replacing the Printhead . . . . .	26
Removal . . . . .	26
Installation . . . . .	26
Packing for Shipment . . . . .	28

# Introduction

## About This Manual

This manual provides setup, cleaning, and basic troubleshooting instructions for the ZC100 and ZC300 Series printers, and their respective factory-installed options. Unless otherwise noted, instructions are identical for all printers.

## About the Printer

The ZC100 and ZC300 series printers provide full color dye sublimation or monochrome thermal transfer printing on standard CR70 (2.051" x 3.303") and CR80 (2.125" x 3.375") PVC or PVC composite 10- to 40-mil cards. The integrated card feeder and flipper minimizes printer size while maximizing performance. Zebra ZC Series ribbon cartridges have an integrated card cleaning roller for easy ribbon changing or replacement. A variety of options (some of which can be factory-installed or field-installed as upgrades) are available.

## Features, Controls, and Indicators

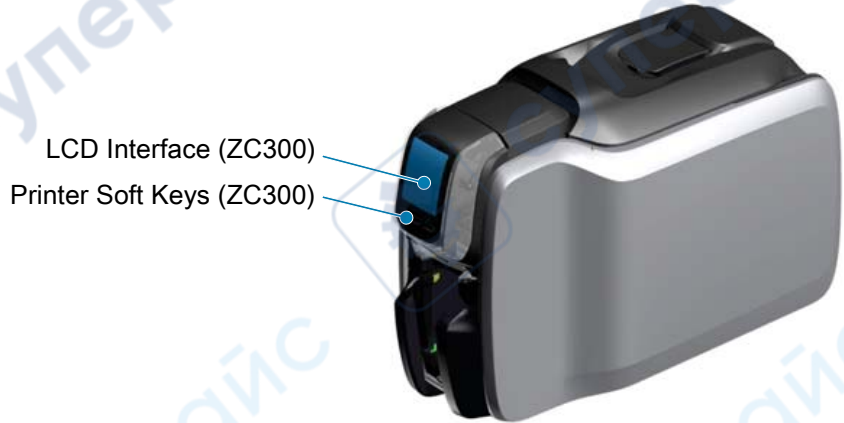
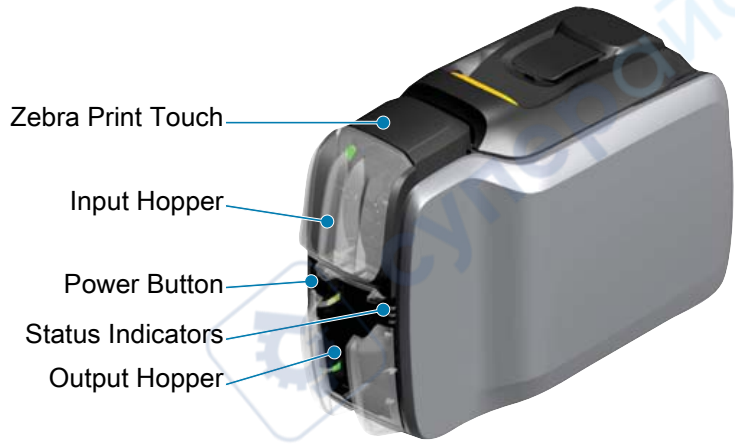



**Zebra PrintTouch**—This touch point uses NFC technology to provide key information about the printer; go to <http://www.zebra.com/nfc> for details.

**LCD Interface**—The ZC300 Series printers are equipped with a LCD interface to display menu items and errors, and three action buttons to enable menu choices.

**Input Hopper**—The ZC100 and ZC300 Series printers have a 100-card (30-mil) hopper capacity.

**Power Button**—The power button houses a red and green LED to indicate the power status.

**Status Indicators**—The ZC100 and ZC300 Series printers are equipped with several indicators that displays printer status, ribbon status, and cleaning status.

**Output Hopper**—The ZC100 and ZC300 Series printers are equipped with a 100-card (30-mil) hopper capacity.

**Top Cover Release**—Open the top cover to load and remove printer ribbon, clear a card jam, install upgrades, and access the printhead for easy replacement.

**Power**—The ZC100 and ZC300 Series printers use a 100-watt power supply. Make sure to use the power supply that came with the printer.

**USB 2.0**—For direct connection to a PC.

**10/100 Ethernet**—Used to connect the printer to a network.

## LCD Menu Navigation

### Printer Ready Screen

After successful startup, the printer will display the ready screen.

The printer ready screen displays the wired (Ethernet), Bluetooth, and wireless (Wi-Fi) status at the top; the current printer state in the center; and Help, Info, and Tools at the bottom.



### Printer Soft Keys

There are three soft keys (buttons) that sit under the LCD and correspond to what is displayed in the lower portion of the screen. As the menus change, the function of the soft keys change. For example: At the Printer Ready screen, pressing the leftmost key will take you to the Help menu; once in the Help menu, the function of the keys change to navigation arrows.

Navigation arrows are used to cycle through the menu choices, return to the previous menu, and make the desired selection. For example: At the Help menu, the leftmost key corresponds to the left arrow which return you to the previous menu; the center key corresponds to the down arrow which is used to cycle through the menu choices; and the rightmost key corresponds to the right-facing chevron which is used to select the menu choice and go to the next menu.



## Help Menu

The Help menu offers brief animations to assist you with basic tasks. From the Help menu, use the soft keys to navigate through the different choices and press the rightmost key to select.

The Help menu displays the following:

- Loading cards
- Loading ribbon
- Printing demo card
- Cleaning printer
- Clearing card jam
- Clearing ribbon jam
- More help

If the topic you need isn't listed in the help menu, select More help and a QR code will be displayed. Scan the QR code with your mobile device and you will be directed to the printer support page.

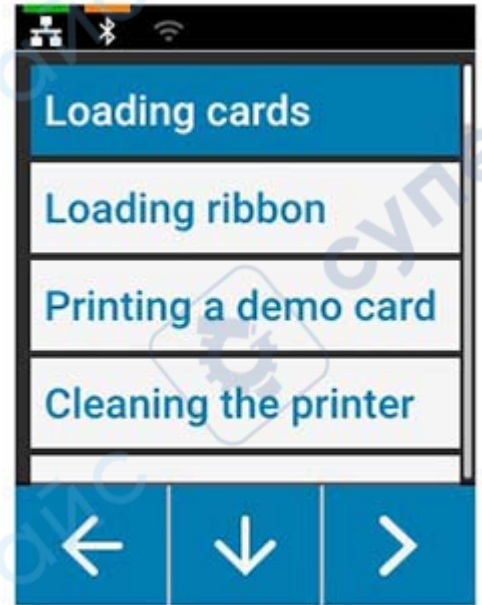

### Info menu

The Info menu shows information on the condition and connection of the printer.

The Info menu displays the following:

- Printer info
- Wired network
- Wireless network
- Ribbon info
- Card count
- Installed options

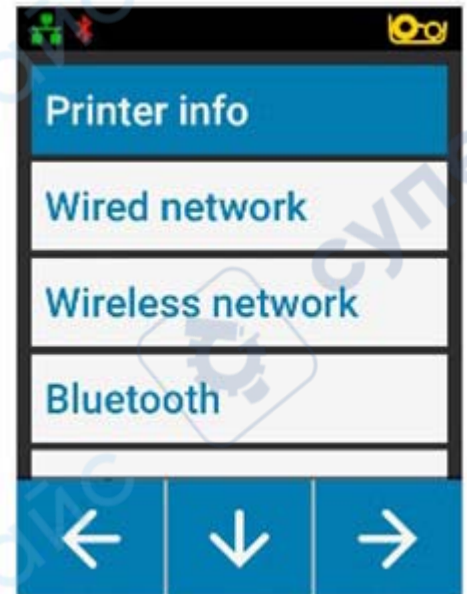

### Tools Menu

The Tools menu enables several basic functions to keep your printer working properly.

The Tools menu displays the following:

- Print sample cards
- Select language
- Clean printer



## Connection Status

The top of the LCD screen shows the connection status of Ethernet, Bluetooth, and Wi-Fi.

### Ethernet Connection

Off	Cable detected but No IP Address	Cable detected with Network

### Bluetooth Connection

Off	Paired but Not Connected	Paired and Connected

### Wi-Fi Connection

Off	No Connection	Poor Connection	Connected

# Setup

## Unpacking

It is important that the printer packaging be saved in case it needs to be returned to Zebra. Maintain the box, bag, and inserts; include the power supply when shipping. You do not need to pack the USB cable or any documentation.

1. Open the box and remove the power supply, power cable, and USB cable.
2. Remove the top tray.
3. Remove the printer in the bag.
4. Remove the printer from the bag and place it in the desired location. Refer to the product Technical Specification ([www.zebra.com/zc100-info](http://www.zebra.com/zc100-info) or [www.zebra.com/zc300-info](http://www.zebra.com/zc300-info)) for weight restrictions and required distances around the printer.

## Connecting Power

The ZC100 and ZC300 Series printers use a 100 watt power supply.

**Do not use any other power supply.**

1. Connect the female end of the power cable to the power supply.
2. Connect the device end of the power supply cable to the printer.
3. Connect the receptacle end of the power cable to a compatible power source.



## Connecting USB

1. Connect the device side of the USB cable to the printer.
2. Connect the PC side of the USB cable to an appropriate computer.



## Connecting Ethernet

1. Connect one end of the Ethernet cable to the printer.
2. Connect the other end of the Ethernet cable to an appropriate network device.



## Loading Ribbon

Each ribbon cartridge includes features that identify the cartridge type to the printer. These features also track usage information so the printer knows when the ribbon is exhausted and prevents the use on non-Zebra branded cartridges.

1. Open the top cover.
2. Remove the cleaning roller protective cover.
3. Insert the ribbon in the orientation shown. The ribbon can only be inserted in one direction, do not force the ribbon into the incorrect position.
4. Close the top cover.



## Loading Cards

The ZC Series of printers support many types of cards in different thicknesses. As shown in the illustration below, cards must be inserted in the proper orientation to work properly.

1. Plain cards are inserted in any direction.
2. Mag stripe cards are inserted with the stripe side down and to the right.
3. Contact smart cards are inserted with the chip facing up and forward.
4. Contactless smart cards are inserted in any direction.



## Printing a Sample Card

1. Make sure the printer is powered on and ready.
2. From the Printer Ready screen, press the rightmost soft key to go to the **Tools** menu.
3. Use the center soft key to move the selection to **Print sample cards** and press the rightmost soft key to select.
4. Use the center soft key to select the card(s) to print.
5. Press the rightmost soft key to begin printing.

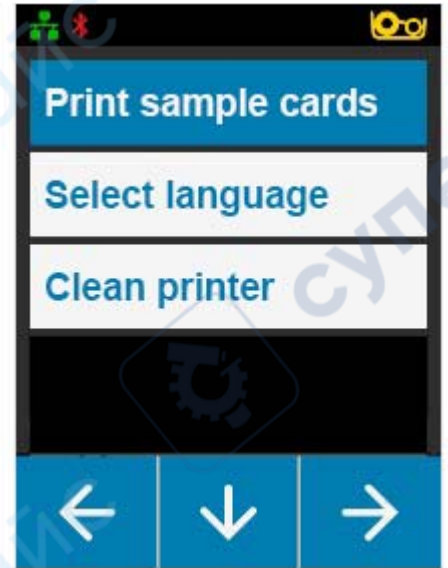

## Installing the Driver

The printer driver is loaded automatically from the Windows Update service when the printer is connected via USB. The driver may be installed manually by downloading from the Zebra web site ([www.zebra.com/zc100-info](http://www.zebra.com/zc100-info) or [www.zebra.com/zc300-info](http://www.zebra.com/zc300-info)).

You cannot download the driver to a mobile device.

You need Internet access to download a driver.

## Manual Feed

Single cards can be inserted via the manual feed slot located at the front of the printer just below the input hopper. Manual feed is selected via the driver. When the manual feed slot illuminates green, insert the card in the same orientation as the cards loaded into the input hopper. When the card is finished printing, it will be sent to the output hopper.



## Retrieving a Rejected Card

When an error occurs during printing, the rejected card is sent to the output hopper.

If the printer is equipped with a flipper module, the rejected card is sent to the reject area located above the flipper.



To retrieve a rejected card:

- From the output hopper, remove the card from the top of the output stack.
- From the reject bin, open the top cover and remove the card (circle above).

# Options

## Mag Encoder

### Magnetic Encoding Type

#### ISO (Default)

The encoder reads and writes standard ISO track data formats in standard ISO track locations. The following shows the three standard ISO tracks.

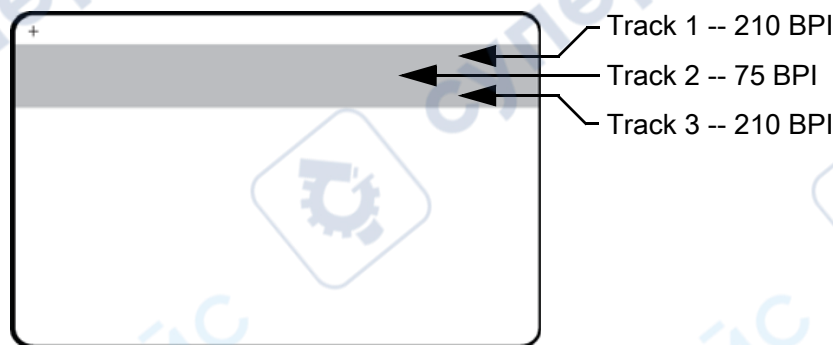

Each track can be encoded and decoded with ASCII characters in the standard default ISO data formats:

Track	Density (BPI)	Bits per character	Character parity	Length (characters)	LRC parity	Start sentinel	End sentinel	Start sentinel offset
1	210	7	Odd	76	Even	%	?	0.293" (7.4 mm)
2	75	5	Odd	37	Even	;	?	0.293" (7.4 mm)
3	210	5	Odd	104	Even	;	?	0.293" (7.4 mm)

The magnetic encoder can read or encode up to 3 tracks of digital information onto CR-80 cards incorporating a HiCo or LoCo magnetic stripe in the ISO 7811 format.

Encoding for the three tracks uses the ISO 7811 format.

- Track 1 uses 210 BPI (bits per inch) encoding in the International Air Transport Association (IATA) format of 79 alphanumeric characters, at 7 bits per character.
- Track 2 uses 75 BPI encoding to store 40 numeric characters at 5 bits per character in American Banking Association (ABA) format.
- Track 3 uses 210 BPI encoding of 107 numeric characters at 5 bits per character in THRIFT format.

The ISO data formats include a preamble (all zeros), a start character, data (7-bit or 5-bit as specified by ISO), a stop character, and a longitudinal redundancy check (LRC) character. The 7-bit data format has 6 bits of encoded data and a parity bit. The 5-bit data format has 4 bits of encoded data and a parity bit.

The ISO data formats include a data field separator (or delimiter) that allows parsing of the encoded track data. An example of separate data fields would be the ABA data format (Track 2) that includes a Primary Account Number (PAN) field and an account information field (for expiration date, country code, etc.).

## Smart Card Encoder

### Contact Smart Cards

Contact Smart Cards have a pad of contacts on the surface of the card that connects to the circuitry embedded into the card.

Encoding data onto Smart Cards and reading the data previously encoded on them is totally under control of the application software; no operator action is required. If you experience any problems with encoding or reading data, refer to the users manual or other documentation for the application software.

All other printer operations remain the same as the standard models.

### Media Loading Orientation for Contact Smart Cards

Place the cards in the input hopper with the gold-plated contact at the top and toward the rear. Ensure that the cards are seated properly in the feeder.

### Printing on Contact Smart Cards

When designing material to be printed on contact smart cards, be sure the printing will not be on the contact area on the front or the back of the card.

### Contactless Smart Cards

Rather than using a contact pad, contactless smart cards use an embedded chip and various short-range radio technologies to encode the card. The printer moves the card to an antenna location on the card path, and the encoding or decoding occurs.

All other printer operations remain the same.

### Media Loading Orientation for Contactless Smart Cards

Contactless smart cards are loaded the same as normal cards.

### Printing on Contactless Smart Cards

When designing material to be printed on contactless smart cards, be sure the printing will not be on the smart chip area; i.e., the printing on **either side of the card** must not be on top of or underneath the smart chip area.

## Contact Station

### Smart Card Interface

When a command to the printer interface sends a card to the smart card contact station, the printer connects the smart card contact station to the female DB-9 connector on the rear of the printer.

### DB-9 Connector (detail)

An attached external smart card programmer can be used to program smart card chips. The following table shows the smart card contact points.

Pin	Smart Card Contact Points	DB-9	Smart Card Contact Points
1	C1 (VCC)	6	C6 (Vpp)
2	C2 (Reset)	7	C7 (I/O)
3	C3 (Clock)	8	C8 (RFU)
4	C4 (RFU)	9	(GND when chip is at station)
5	C5 (GND)		

## Double-sided Printing

The “flipper” printing module enables double-sided printing on applicable printers. Additionally, when the flipper module is installed, rejected cards are sent to the rejected card area rather than the output hopper.

## Wi-Fi

A printer with the wireless option ships with the wireless radio pre-installed in the printer.

Printer location is important to ensure that adequate signal strength is achieved. Follow these suggestions:

- Position the printer as close to the access point that it will connect to as possible.
- If possible, orient the printer such that there is a clear line of sight between the printer antenna and the access point antenna.
- Locate the printer such that there are no intervening walls in the line of sight between the antennas.
- Do not put the printer in a cabinet, especially not a metal one.
- Do not locate large metal objects close to the printer antenna.
- Do not locate the printer close to devices that emit RF radiation in the 2.4 GHz range; such devices might include: microwave ovens, cordless phones, wireless surveillance cameras, baby monitors, wireless video transmitter and Bluetooth devices, etc.

## Description

### Communication

To connect to a wireless network, the printer uses wireless protocol IEEE 802.11b/g that communicates data through radio transmission and can talk to Access Points that are either 802.11b or 802.11g compliant.

The wireless printer communicating over 802.11b radio:

- Allows nominal data rates over the air of 11 Mbps as per 802.11b standard.

- Supports automatic rate scaling starting at 11 Mbps and going down as low as 1 Mbps for maximum range and optimal throughput depending on signal strength.

The wireless printer communicating over 802.11g radio:

- Allows nominal data rates over the air of 54 Mbps as per 802.11g standard.
- Supports automatic rate scaling starting at 54 Mbps and going down as low as 6 Mbps for maximum range and optimal throughput depending on signal strength.

### Security

The wireless printer supports Open System authentication.

The wireless printer supports the following security features:

- Wired Equivalent Privacy (WEP)
- Wi-Fi protected access (WPA/WPA2)

### Encryption

The wireless printer supports the following encryption protocols:

- RC4 (applicable to WEP)
- TKIP (applicable to WPA)
- CCMP (a form of AES encryption applicable to WPA2)

The printer supports the Personal mode of dynamic encryption key deployment, Personal Shared Key (PSK).

### Configuration

Wi-Fi configuration can be accomplished via the driver software.

# Cleaning

## Cleaning the Printer

The Cleaning indicator ✨🧹 on the ZC100 and ZC300 Series printers will flash amber when cleaning is required.

### From the LCD Menu

1. Make sure the printer is powered on and ready.
2. Go to the Tools menu by pressing the rightmost soft key.
3. Use the center soft key to move the selection to Cleaning and press the rightmost soft key to select.
4. The following screen will be displayed:

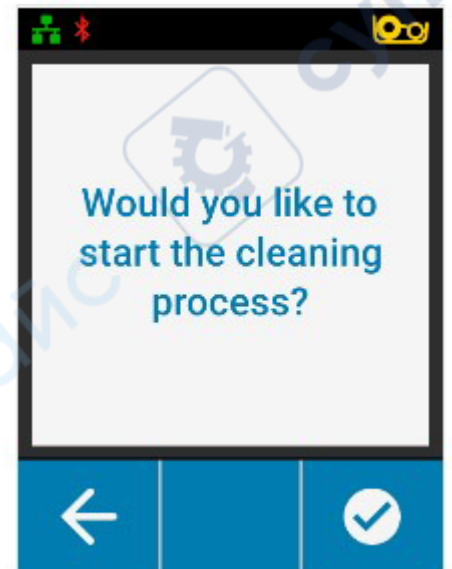

## Cleaning

5. Press the rightmost soft key to proceed with the cleaning process; press the leftmost soft key to cancel and go back to the previous menu.

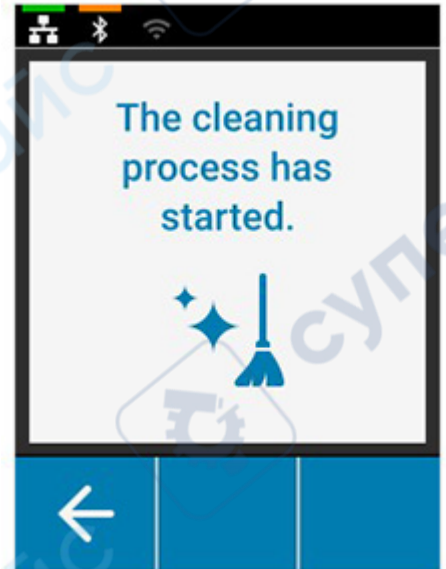

### From the Driver Software

1. Open the Printing Preferences control panel.
2. Click on the Help & Support tab.
3. In the Cleaning section of the Help & Support window, click on Clean Now.

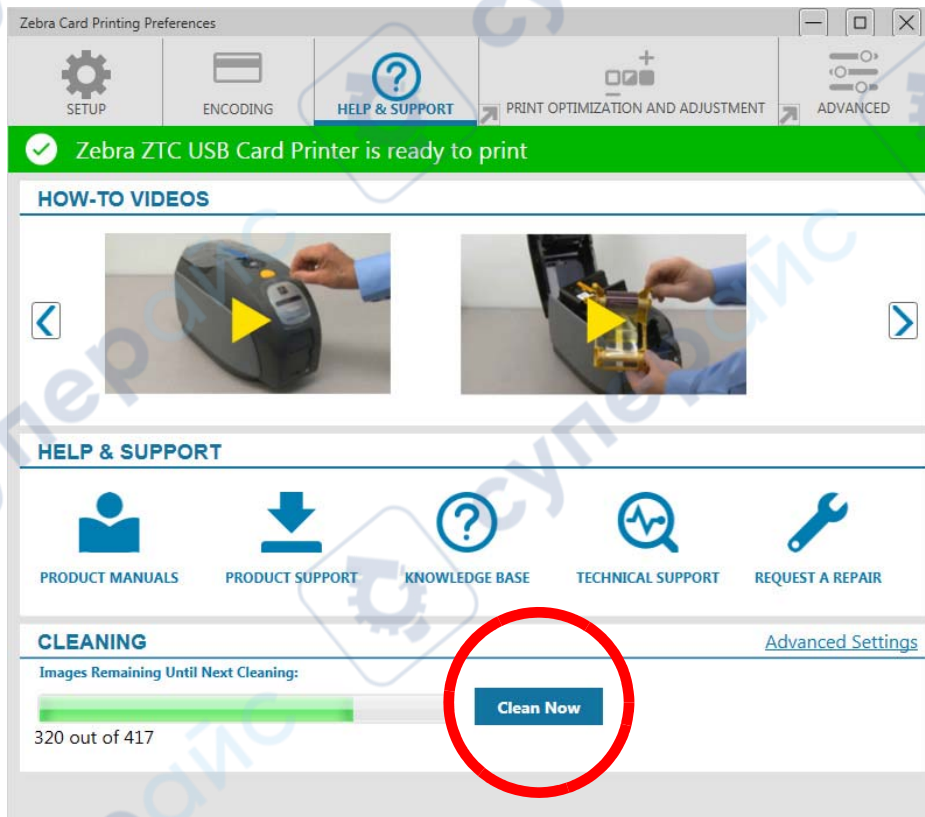

4. Follow the instructions on the LCD screen on the printer.

### Cleaning the Printhead

Use of the cleaning cards will normally do an adequate job of cleaning the printer. However, a separate Printhead cleaning, using swabs, can remove more stubborn deposits when print anomalies persist. To avoid deposits, only use foam-tipped swabs.



Never use a sharp object to scrape deposits from the printhead. Permanent damage to the printhead will result.

1. Turn the printer off.
2. Open the top cover.
3. Clean the Printhead by moving an alcohol-moistened swab tip side-to-side across the printhead elements.
4. Allow two to three minutes for the printhead to dry before turning the printer on.

### Cleaning the Mag Encoder

1. Turn the printer off.
2. Open the top cover.
3. Clean the mag encoder by moving an alcohol-moistened swab tip side-to-side across the encoder element.
4. Allow two to three minutes for the printhead to dry before turning the printer on.

### Cleaning Supplies

Cleaning supplies can be ordered from the product support page.

# Troubleshooting

## LCD Warnings and Errors

Warnings require operator attention, but do not prevent the printer from successfully completing the job.





Pressing the leftmost soft key takes you to an animation showing how to resolve the warning.

After the animation, a **QR code** will be displayed. Scanning the QR code with your mobile device will take you to the printer support page.

Errors require the operator to take immediate action to continue printing. There are no animations for error states.



## LED Warnings and Errors

Indicator	Blinking Green	Solid Green	Solid Amber	Blinking Red	Solid Red
Power 	Booting Up	Power On	N/A	N/A	Critical error
Card 	Printing/ Encoding in progress	Cards available	N/A	Card jam	Cards out
Ribbon 	Printing in progress	Ribbon available	Ribbon low	Ribbon out/ ribbon jam/ ribbon break	Invalid ribbon
Clean 	Cleaning in progress	Cleaning complete (end at 30 seconds)	Cleaning warning	N/A	Cleaning error/reject bin full
Manual Feed	N/A	Ready for card/cleaning card	N/A	N/A	Card insert error

## Clearing a Card Jam

A card jam is reported by the printer when a card fails to reach a sensor as expected, or a card blocks a sensor unexpectedly.



Do not use tools to remove stuck cards, this will void the product warranty and may cause damage to the equipment.

1. Open the printer.
2. Remove the ribbon cartridge.

3. Rotate the manual advance wheel toward the front of the printer until the card exits the printer.



## Identifying Print Quality Issues

Print quality refers to the quality of the text, barcodes, and images that are printed on the card.

### Color Accuracy

When the colors on the printed card do not match the expected result, there are several steps that may be taken to get the desired output.

1. If using the driver, make adjustments in Color Optimization.
2. If using the driver, create and apply a Windows ICC color profile.
3. Whether using the driver or not, contact Zebra to create a custom lookup table.

### Dirt and Debris

Spots and speckles appearing on the card may be caused by dirt and debris in the printer.

- Replace the cleaning rollers
- Clean the printer

### Image Placement

If the image printed on the card seems to have shifted, this may be an image placement issue.

- From the driver, use the Print Position adjustment feature.

### Smear

Smear may occur when a sudden shift from a dark color to a light color occurs and the printhead has not sufficiently cooled when printing the light color, thereby the dark color appears to “smear” into the light color.

- From the driver, Lower the Preheat value in Color Optimization.

### Black Extraction

When the black text or images does not appear black or crisp, or text that is supposed to be black appears muddy or not sharp, this may be an issue where the black text or image was not printed using the black panel.

- Check the source image; RGB values up to 25,25,25 can be printed as black by using the sliders on the K Extraction page. If RGB values are greater than 25,25,25, then the image will need to be modified to bring the RGB values under this threshold
- Adjust the properties in Front or Back K Extraction.

### Ribbon Wrinkle

Ribbon wrinkle appears as a streak of color that was not part of the original image. It typically originates from the edges of the card, and sometimes occurs when printing a really dark image, or near the transition between really dark and really light images

If this occurs, contact Zebra Tech Support.

### Mis-registration

Mis-registration occurs when the Y, M, C, and/or K panels are not properly aligned with each other. The effect may appear as a lack of sharpness, or a color halo.

If this occurs, contact Zebra Tech Support.

### Replacing the Printhead

#### Removal

1. Open the top cover
2. Push the printhead upward and then rotate to release the printhead assembly from the hooks.
3. Disconnect the cable connector from the printhead.

#### Installation

1. Connect the cable connector to the new printhead.
2. Note the serial number and resistance value of the new printhead.



3. Insert the stabilizer ball into its receptacle on the top cover.
4. Push the printhead upward and then rotate into the hooks.

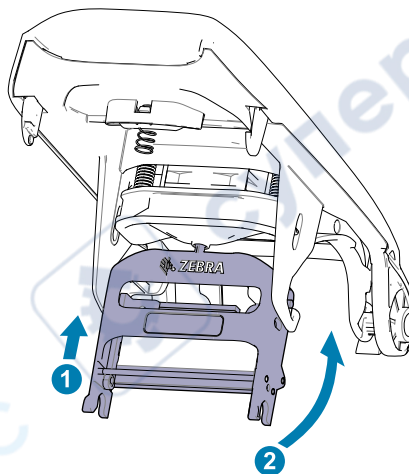

5. Open the printer driver and click on the Advanced tab, then click on Diagnostics and Calibration, then click on Commands & Calibration.
6. Under Printhead, enter the serial number and resistance value of the new printhead.

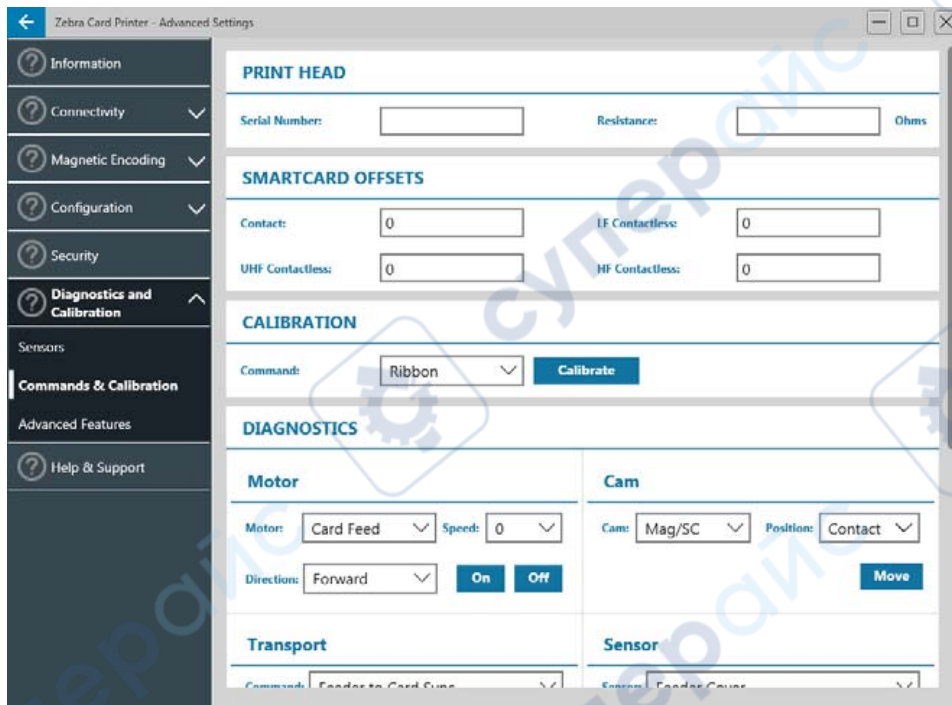

## Ethernet

### Indicators

Orange — Link Speed Indicator

Off	No link (disconnected)
1 Blink	The LED blinks once (one blink, pause, one blink, etc.) when a 10Base link has been established.
2 Blinks	The LED blinks twice (two blinks, pause, two blinks, etc.) when a 100Base link has been established.

Green — Link Activity Indicator

Off	No link (disconnected)
On	Network link has been established
Blinking	Network activity has been detected

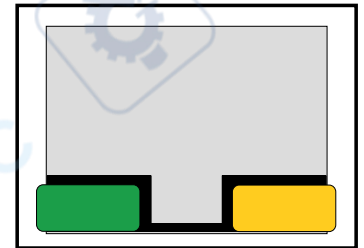

### Issues

If both LEDs are off, the printer has not detected the presence of a network cable. To solve the problem:

- Verify that the network cable is appropriate and has an RJ-45 connector.
- Remove the network cable from the printer. Plug the network cable back in until you hear a positive click. Check the other end of the cable in the same manner. If the printer still does not detect a cable, then continue.
- Connect the printer to a known good network. If the printer is still unable to detect the network cable, contact Technical Support for assistance.

### Packing for Shipment

It is important that the printer packaging be saved in case it needs to be shipped to a different location. Maintain the box, bag, and inserts; include the power supply when shipping.

1. Place the printer in the bag.
2. Place the bagged printer in the shipping box in its proper orientation.
3. Place the top tray.
4. Place the power supply and power cable into the top tray.
5. Close the box.

For further assistance, visit the support site ([www.zebra.com/zc100-info](http://www.zebra.com/zc100-info) or [www.zebra.com/zc300-info](http://www.zebra.com/zc300-info)) where you will find:

- How-To videos for common tasks
- Driver and utility software
- Specialized user documentation